

Versatile, high-performance forward plate compactor

Premium asphalt plates feature a durable base plate for various applications. A true combination plate for various applications in the 85-90 kg weight class.

Designed for the compaction of granular and mixed materials with some cohesive content in confined areas such as parking lots, highway and bridge construction, next to structures, curbs, and abutments. This computer designed base plate has a tapered bottom and edges for high speed and excellent manoeuvrability.



POWERED BY
HONDA
norm SAE J1349



EGX
POWERED BY
HONDA
*ECOPOWER



Waterproof and ultra-strong battery storage case for maximum safety



FEATURES AND BENEFITS

- The straight, centre-mounted guide handle offers superior manoeuvrability and can be lowered within inches of the surface to operate the plate under obstacles and form work.
- Many lifting points and a front lift cage offer easier loading and unloading for operator convenience.
- Compact design, easy to use, cast bottom plate.
- Smooth and flexible.
- Throttle mounted on the operating handle.

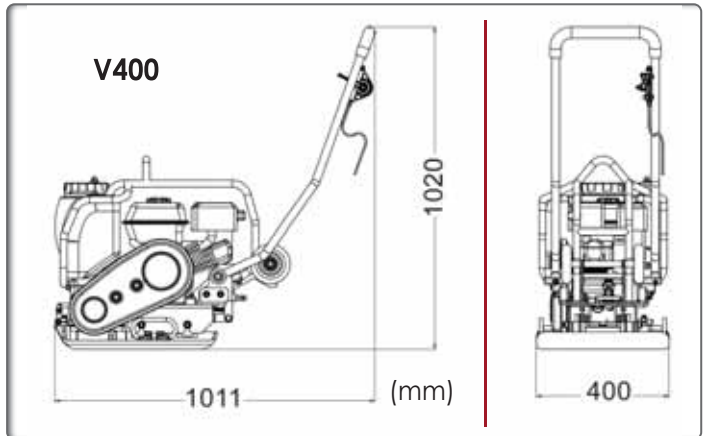

Code	V400 COMBI	V400-ECO
Model	V400 COMBI	V400 ECOPOWER
Operating mass (kg)	85	97
Centrifugal force (kN)	14	14
Plate width (mm)	400	400
Engine	Honda GX160	Honda EGX
Net power hp (kW)	4,8 (3,6)	2,4 (1,8)
Rated engine speed (rpm)	3600	3600
Fuel tank capacity (L)	3,1	-
Engine oil capacity (L)	0,6	-
Fuel consumption at rated power (L/h - rpm)	1,4 - 3600	-
Water tank (L)	13	13
Speed (m/min)	21	25
Amplitude (mm)	0,89	0,89
Frequency (Hz)	95	95
Sound pressure level dB (A)	91	55
Vibrations* (m/s ²)	2,62	3,62
Surface capacity (m ² /h)	685	805
* Minimum vibration levels measured to EN500-4		
Certified power SAE J 1349		

OPTION: PAVING PAD	
Code	PPV-PAD400



Option: Accessory - stone paving pad, essential accessory for the installation of slabs or pavers.

