

Diesel trench rammer

This PACLITE diesel rammer offers maximum production, performance and durability while providing you the convenience of standardizing your diesel fleet. A well-balanced machine for easy handling and operation.

The TR800DY is the heavyweight amongst the rammers and is exceptionally reliable because of its engine. Its preferred use is on soils which are difficult to compact, on sites where solely diesel fuel is used to avoid the accidental mix up of fuels and also on various repair jobs.

FEATURES AND BENEFITS

- The durable Paclite diesel KM173F engine provides exceptional performance, fuel economy and long life.
- The large capacity fuel tank with self-cleaning in-tank filter, offers long life and minimum maintenance.
- Exclusive noise reducing cover lowers the amount of engine and shoe noise transmitted to the operator.



Dual air filter

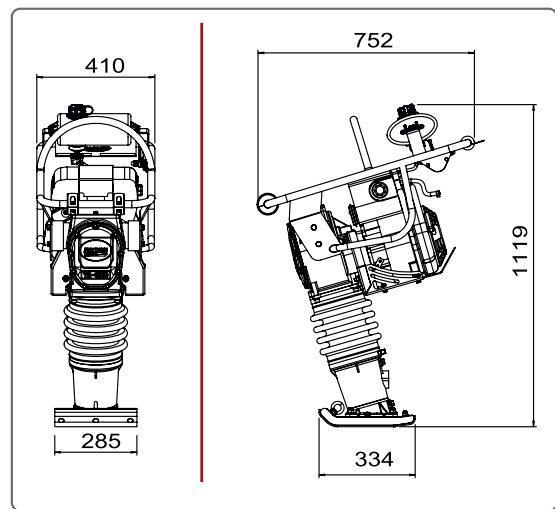

Reduced operating costs: long service life; dry air filter cartridge with self-cleaning air filter system

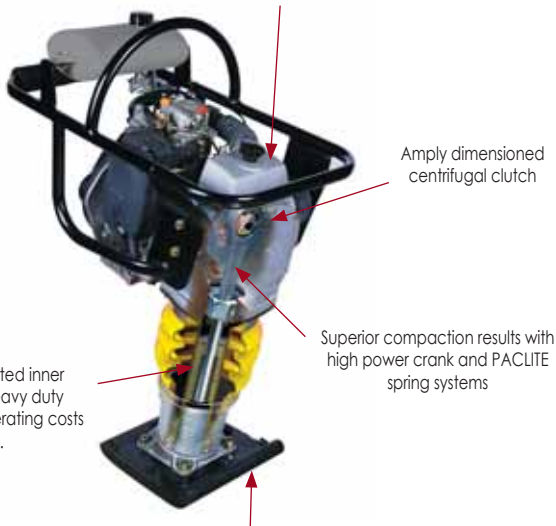

Amplly dimensioned centrifugal clutch

Superior compaction results with high power crank and PACLITE spring systems

The nitride-plated inner sleeve and heavy duty springs keep operating costs down.

High travel speed with improved foot inclination angle, optimized spring systems and low centre of gravity.



Wheel kit OPTION	
Code	OP/TR-WHEEL

Code	TR800DY
Model	TR800DY
Operating weight (kg)	84
Centrifugal force (kN)	21,4
Plate size (mm)	334 x 285
Engine	Paclite KM173F diesel
Power hp (kW)	5,5 (4,07)
Engine speed (rpm)	3600
Cooling system	Forced air cooling (fan)
Fuel tank capacity (l)	2,5
Fuel economy (g/kWh)	~280-290 typical
Speed (m/min)	9 - 12
Amplitude (mm)	75 - 85
Frequency (Hz)	12
Sound level dB (A)	92
Vibrations* (m/s ²)	9,6
* Minimum vibration levels measured to EN500-4	
Certified power SAE J 1349	