

## 900 mm Dual Drum Roller

Drum width of **900 mm** is primarily used for small-scale compaction work such as pavement cycle paths, small roads, and small parking areas. The large-diameter drum and drive motors connected in series contribute to its excellent accessibility and hill-climbing capacity. Propulsion and vibration come as standard on both drums.

Designed for compacting base and finishing layers of asphalt as well as granular sub-base material in confined areas. Ideal for parking lots, driveways, and shoulder work.



Powered by  
**Kubota**

Quieter than before

High visibility during operation

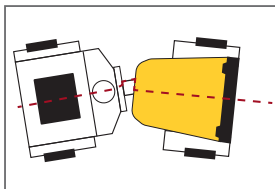

The shape of the roller provides high visibility around the edges of the rollers during operation.

High stability while driving

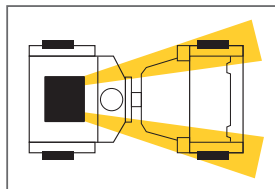

Operator security and comfort with PACLITE designed oscillating pivot steering on uneven surfaces or while turning.

## FEATURES AND BENEFITS

- Three position function vibrator switch, dual drum vibration with possibility switch off rear drum and front drum only vibration. Work lights front and rear, variable hydrostatic steering forward and reverse. Pressurized sprinkler system.
- Lights on both sides of the machine.
- Hydrostatic drive with variable speed.
- Self-cleaning drum for good traction and better surface finish with 2 scrapers.
- Large-size water tank for extended use and reduced refill stops, easy cleaning access.
- Self-draining sprinkler tubes and nozzles.
- Long service intervals together with comfort.
- Dual forward/reverse levers for total operator comfort.
- Scrapers on each cylinder, maintained and folding spring.
- Fuel level gauge.
- Emergency stop.
- Back-up alarm.
- Central lifting point.
- Vandal-proof protection.
- Engine cover lock.
- Max. m/min 183.
- Crossing slope with vibrations 32%.
- Slippery slope without vibration 42%.

Code	RM900D
<b>Model</b>	<b>ROADMASTER 900</b>
Dimensions L x H (mm)	2095 x 2560
Operating weight (kg)	1620 with ROPS
Weight on cylinder front/rear (kg)	740/835
Drum size (mm)	900
Centrifugal force (kN)	28
Amplitude (mm)	0,60
Static line load front/rear drum (kg/cm)	8,3/9,4
Frequency (Hz)	69
Engine Kubota D1105-E4B T4f	3 cylinders
Cooling	Water
Emission regulation	Tier 5
Engine power - hp (kW)	25 (18,5)
Water tank capacity (l)	110
Brand Hydraulic system	POCLAIN/CASAPPA
Certified power SAE J 1349	



Kubota engine with linear assembly to allow access and maintenance from both sides of the engine.



Roller features support transport rail



Lockable hood



Fiberglass hood



Ergonomic steering wheel

Operator comfort



Ergonomic seat

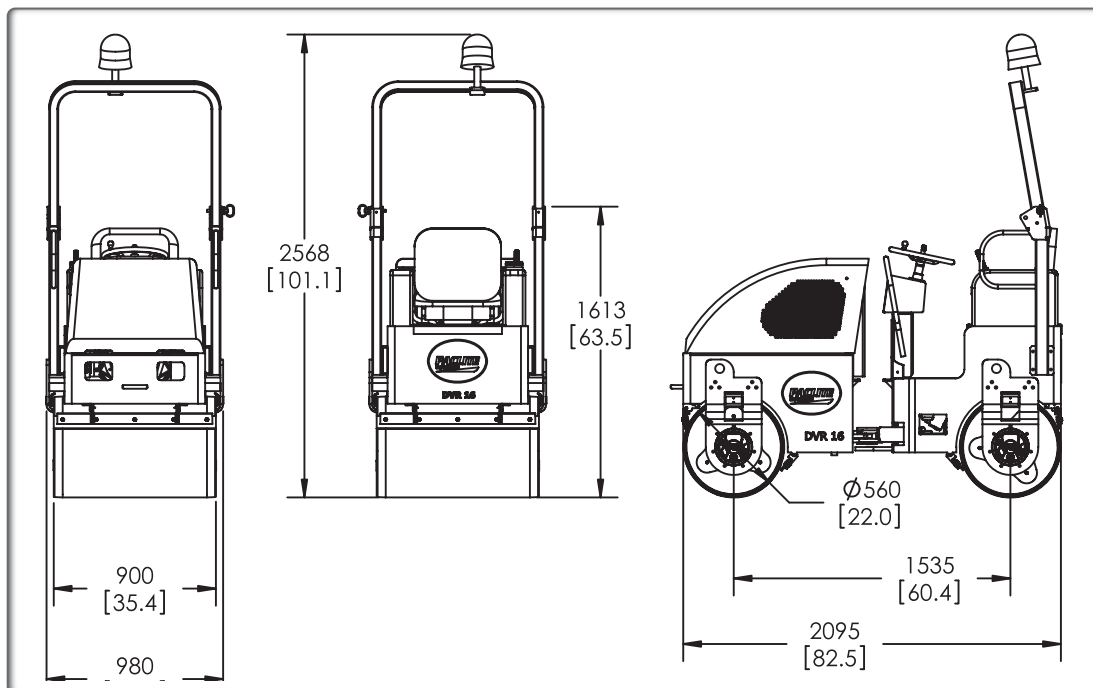

Lubrication point on each cylinder and Poclair drive motors



Unique pivot articulation with grease point



Diesel fuel cap easy access on operator floor

PROPULSION	
System Type CASAPPA (Italy)	Closed-loop, hydrostatic, parallel circuit
Drum drive system POCLAIN (France)	Pump: axial piston; Motor: radial piston, low speed, high torque
Speed (km/h)	0 – 10,0
Gradeability (theoretical)	35 %
BRAKES	
Service	Dynamic hydrostatic through propulsion system
Parking/Secondary	Spring-applied hydraulically released (SAHR) on each drum drive
WATER SYSTEM	
Type	Pressurized
Pump	Electric, diaphragm
Water tank capacity	110 litres
Filters	Filters 100 mesh screen @ nozzles, 80 mesh in-line
Drum Wipers Type	Spring-loaded, self-adjusting, neoprene wipers
MISCELLANEOUS	
Fuel Capacity	31 litres
Hydraulic Oil Capacity	30,1 litres
Oscillation	+/- 8° +/- 8°
Curb Clearance — Vibration/Traction (mm)	337
Side Clearance (mm)	40

Compaction work with 2 cylinders

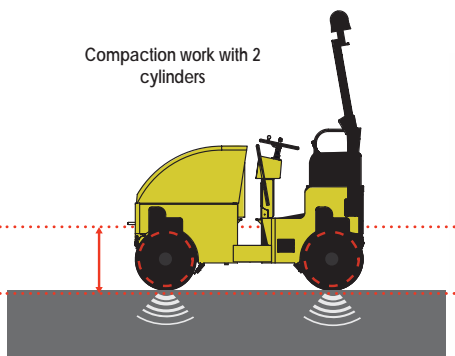

Vibrating drums



Rotating warning light and serial ROPS protection

The specially designed vibrating cylinder oscillates the material to be compacted optimally by vertical forces in rapid succession. Integrated unbalance eccentric provides high frequency and exceptional compaction quality.

COMPACTION

MOBILE EQUIPMENT

CONCRETE EQUIPMENT

SURFACING

CUTTING - GRINDING