

## Heavy forward plate - gasoline or diesel

PACLITE vibratory plates offer functionality and performance at a value price. Compact design allows for compaction of mixed soils in the narrowest of spaces - even in extremely narrow trenches. Ideal for curbs, gutters, around tanks, forms, columns, footings, guard railings, drainage ditches, gas, sewer works and building construction.

These plates are optimally suited for a variety of compaction applications thanks to their high speed of advance and simple manoeuvrability.

Two types of engines are available: gasoline and diesel.

## FEATURES AND BENEFITS

- Newly designed "low-vibration" guide handle greatly improves operator comfort and minimizes operator fatigue.
- Completely enclosed belt protected by a lightweight belt guard for reduced wear and minimal service.
- Ergonomic lifting handles facilitate loading and unloading from transport vehicle.
- Durable shock mounts on the engine console dampen vibrations, thereby reducing wear on the components.
- Devibrated handle with 'cup design' to reduce hand-arm vibration.
- Transport wheels and water kit included.
- Throttle mounted on the operating handle.



Carbon belt cover

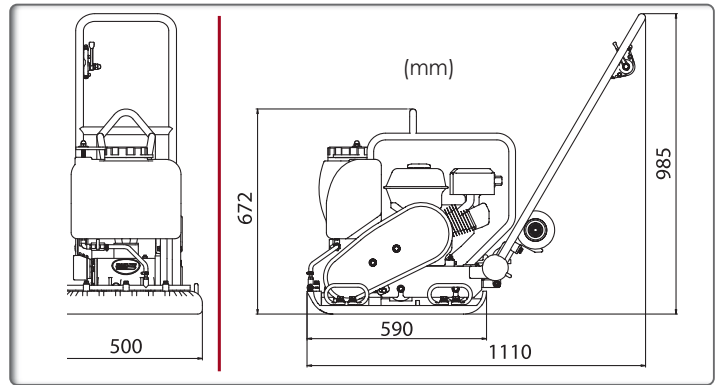

Code (CE)	PC100H	PC100DH
Model	PC100 Honda	PC100 Hatz
Operating mass (kg)	96	125
Centrifugal force (kN)	20	20
Plate width (mm)	500	500
Engine brand	Honda GX160 Gasoline	Hatz 1B20-V5 Diesel
Net power hp (kW)	4,8 (3,6)	4,7 (3,46)
Rated engine speed (rpm)	3600	3100
Fuel tank capacity (L)	3,1	3,5
Fuel consumption at rated power (L/h - rpm)	1,4 - 3600	0,7
Water tank (L)	13	13
Speed (m/min)	25	26
Amplitude (mm)	0,95	0,9
Frequency (Hz)	95	90
Sound pressure level dB (A)	91	101
Vibrations* / (m/s <sup>2</sup> )	3,94	3,94
Surface capacity (m <sup>2</sup> /h)	750	750
* Minimum vibration levels measured to EN500-4		
Certified power SAE J 1349		



Water Sprinkler System

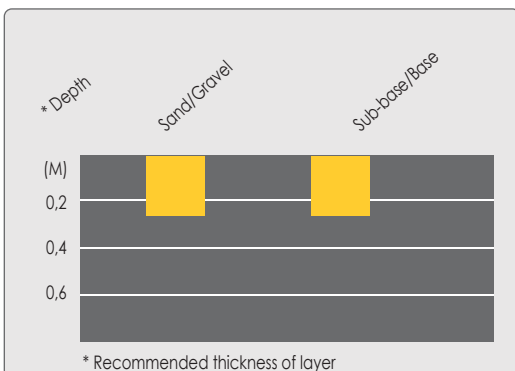

Transport wheels included



OPTION: PAVING PAD	
Code	PPV-PAD100



COMPACTOR

MOBILE EQUIPMENT

CONCRETE EQUIPMENT

SURFACING

CUTTING - GRINDING