

Extra lightweight compactor

Designed for repair in confined areas. These plates are ideal for curbs, gutters, block paving around houses, tanks, forms, columns, footings, guard railings, drainage ditches, gas and sewer lines, and building works.



Ultra compact design

POWERED BY
HONDA
norm SAE J1349



FEATURES AND BENEFITS

- Special contoured surfaces, rounded edges, and its low weight provide maximum performance and manoeuvrability.
- Completely enclosed belt protected by a lightweight belt guard for reduced wear and minimal service.
- Exciter bearing design requires minimal maintenance for improved productivity.
- Ergonomically designed foldable handles offer easier loading and unloading for operator during transport.
- Low HAV mechanism.
- Throttle cable mounted on the operator handle.

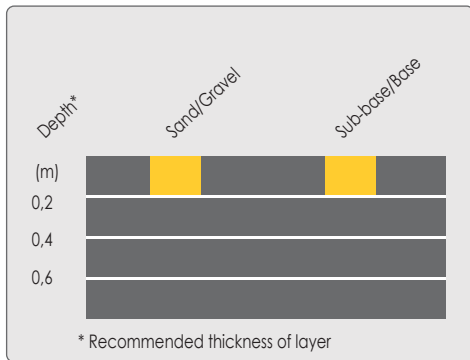
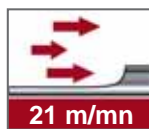
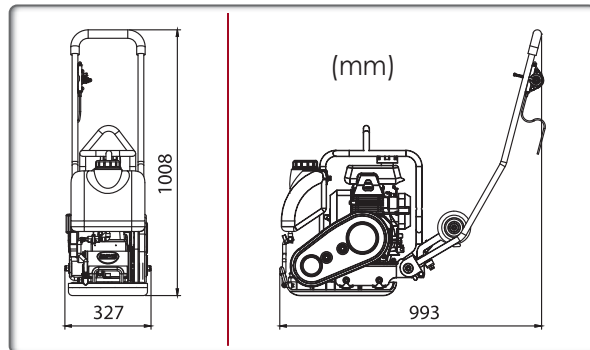

Code	LCC40W
Model	LCC40W
Operating mass (kg)	45
Centrifugal force (kN)	11,5
Plate width (mm)	320
Engine	Honda GXR120
Power hp (kW)	3,5 (3)
Water tank (L)	6
Speed (m/min)	21
Amplitude (mm)	0,89
Frequency (Hz)	95
Sound pressure level dB (A)	89
Surface capacity (m ² /h)	525
Vibrations* (m/s ²)	3
* Minimum vibration levels measured to EN500-4	
Certified power SAE J 1349	



Transport wheels included