

Maximum cutting speed and smooth operation

The PACLITE CUT SPEED 450 Honda floor saw offers a cutting performance second to none in this class of machines. The torque transmitted to the diamond blade and the centre of gravity located directly over the cutting shaft have been matched efficiently. The majority of the engine's power output goes there where it is needed: into the asphalt or the concrete. These two features result in cuts faster than comparable products.

FEATURES AND BENEFITS

- This machine provides excellent directional stability due to the high tensile strength of the protective cage.
- An adjustable handle makes fatigue-free positioning possible for ease of operation. The CUT SPEED 450 features a shorter wheelbase to make the handling of the machine even easier.
- The plastic removable water tank allows extended wet cuts and is the largest in this class of equipment.
- This machine is always perfectly balanced when hanging from the central lifting point for ease of transport.
- Light floor saws in their class, these units offer easy manoeuvrability around any job site.
- Electronic hour meter.
- Easily removable watering kit, centre lifting point.
- Integrated document and toolbox.

POWERED by
HONDA
norm SAE J1349



Height adjustable handle

EN13236



Ø 350,400 & 450 mm



Water tank 25 L



Central lifting point



Double sprinkler



Max blade diameter 450 mm

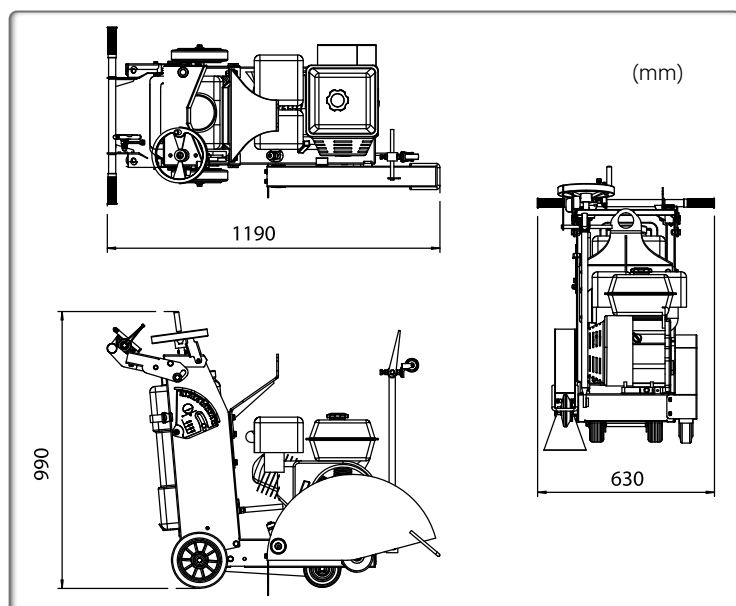

Code	301.40.10002
Model	CUT SPEED 450
Dimensions L x W x H (mm)	1190 x 630 x 990
Weight (kg)	95
Max cutting depth (mm)	145
Cutting width (mm)	10
Blade size (mm)	350, 400, 450
Blade speed (m/s ²)	46,1
Water tank capacity (L)	25
Engine	Honda GX390
Net power hp (kW)	11,7 (8,7)
Rated engine speed (rpm)	3600
Fuel tank capacity (L)	6,1
Engine oil capacity (L)	1,1
Fuel consumption at rated power (L/h - rpm)	3,5 - 3600
Certified power SAE J 1349	