

## Correcting a concrete floor

PACLITE CUB grinder is a small floor grinder developed for correcting and rectifying any concrete surface. This machine is equipped with a powerful single-phase electric motor.

The removable diamond tool set is easy to access and replace.

The folding handle makes the machine compact and easy to transport.

## FEATURES AND BENEFITS

- Tool set is easy to change.
- Powerful electric motor.
- Adjustable handle.
- Outlet for connecting a dust extractor for indoor work.
- One set of diamond segments is included in the machine.

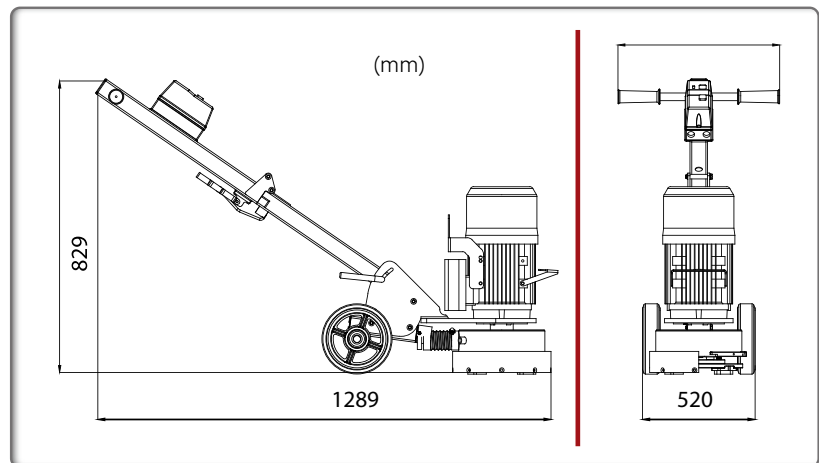

Code	PSG-SEA
Model	Cub Grinder
Working diameter (mm)	230
Segments	5
Dimensions (folded) L x W x H (mm)	800 x 460 x 700
Packing size (mm)	800 x 500 x 820
Net weight (kg)	53
Engine speed (rpm)	1430
Power source electric engine	220-240 V at 2,2 kW (3 hp) 50 Hz

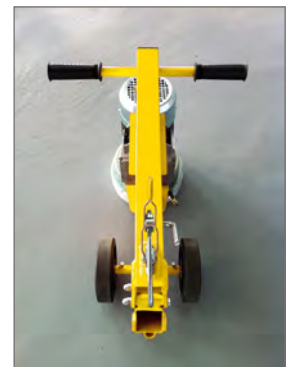
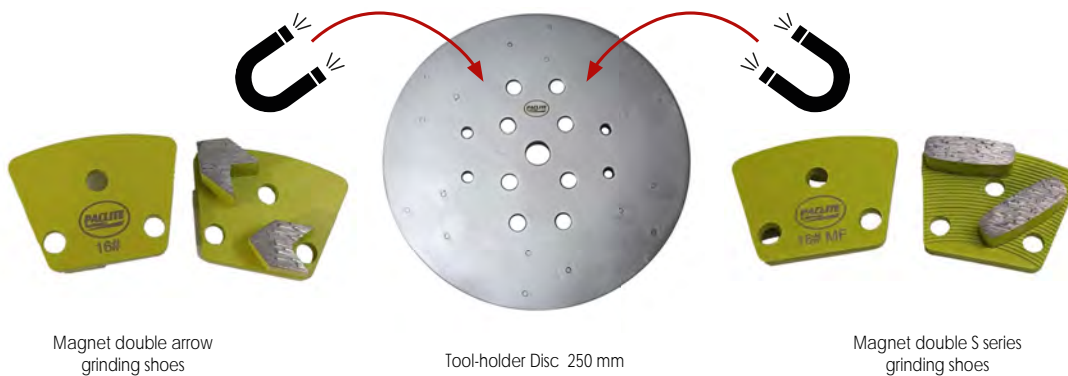
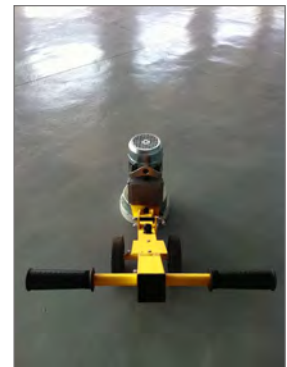

Model	Code
Disc 250mm	PAC-DP314001004
Segment For coating removal Double arrow grinding shoes 2T x 15 mm	PAC-T310100223
Segment For Medium hard bond Double S series grinding shoes 2T x 40 x 13 x 12 mm	PAC-T310100235

COMPACTON

MOBILE EQUIPMENT

CONCRETE EQUIPMENT

SURFACING

CUTTING - GRINDING