

Mechanical ride-on trowel

The Mechanical PRT168 ride-on trowel is equipped with a high-horsepower gasoline engine, heavy-duty drive trains, and packed in easy-to-service frames.

Our heavy-duty gear box and four-bladed rotors are proven performers in the field. PACLITE PRT rider combines exceptional performance with a perfect balance.

It allows quick finishing of a large concrete surface, and, at the same time, ensures it is flat and smooth.

FEATURES AND BENEFITS

- Independent manual pitch control.
- Raised foot pedals.
- Powered retardant spray system.
- Centrifugal clutch.
- Five-blade spider with heavy-duty gearbox.
- Four lights.
- Safety switch built-into the seat.
- Epoxy-painted structure.
- Option: transport trolley with inflatable wheels.



POWERED by **HONDA**
norm SAE J1349

Code	PRT168
Model	PRT168
Dimension L x W x H (mm)	1980 X 1040 x 1350
Operating weight (kg)	333
Panning path width (mm)	1880
Rotors diameter (mm)	914
Maximum rotor speed (rpm)	110 To 135
Engine	Honda GX690
Net power hp (kW)	22,1 (16,5)
Rated engine speed (rpm)	3600
Fuel tank capacity (l)	23
Engine oil capacity (L)	1,9
Fuel consumption at rated power (L/h - rpm)	6,7 - 3600
Spray system	Pressurized
Application	Finishing/panning
Hand vibration (m/s ²)	3
Rated Power kW (hp)	16,5 (22,1)
Foot vibration (m/s ²)	5,73
Seat vibration (m/s ²)	2,76
Sound level guaranteed dB (A)	86,8
Sound pressure level dB (A)	55
Certified power SAE J 1349	

Options	Code
Trowel pans with 8 inserts for left and right rotor (2 per machine)	PRT168M-04712
Set of 4 blades (8 blades per machine)	947-050000
Slings 6 inches 150 mm	PRT168M-035461
Transport wheels 'Dolly jacks' 2/set	PRT168M-027684

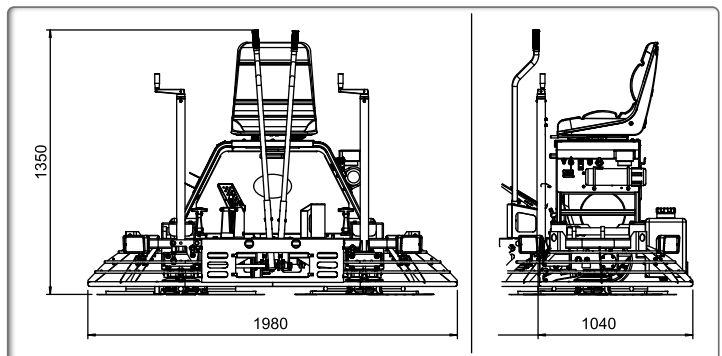

Two water tanks



Transport wheels 'Dolly jacks'



Cup holder



Electric spray system in handle

COMPACTON

MOBILE EQUIPMENT

CONCRETE EQUIPMENT

SURFACING

CUTTING - GRINDING