

## Diesel trench rammer

This PACLITE diesel rammer offers maximum production, performance and durability while providing you the convenience of standardizing your diesel fleet. A well-balanced machine for easy handling and operation.

The TR800D is the heavyweight amongst the rammers and is exceptionally reliable because of its engine. Its preferred use is on soils which are difficult to compact, on sites where solely diesel fuel is used to avoid the accidental mix up of fuels and also on various repair jobs.



Powered by



Dual air filter



## FEATURES AND BENEFITS

- A durable HATZ 1B20 diesel engine provides exceptional performance, fuel economy and long life.
- The large capacity fuel tank with self-cleaning in-tank filter, offers long life and minimum maintenance.
- Exclusive noise reducing cover lowers the amount of engine and shoe noise transmitted to the operator.
- New clutch system from German Amsbeck.

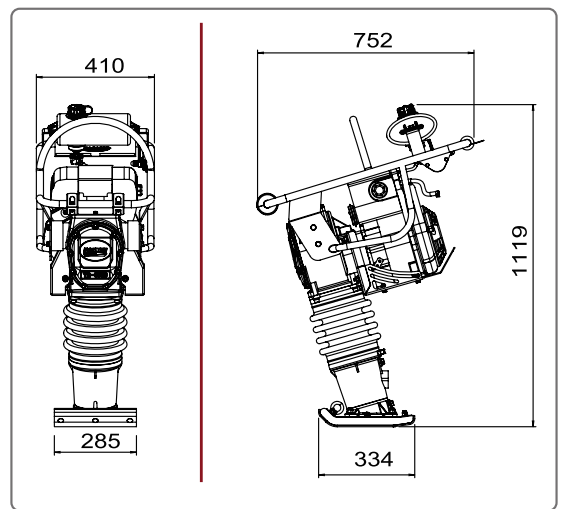

Reduced operating costs: long service life; dry air filter cartridge with self-cleaning air filter system

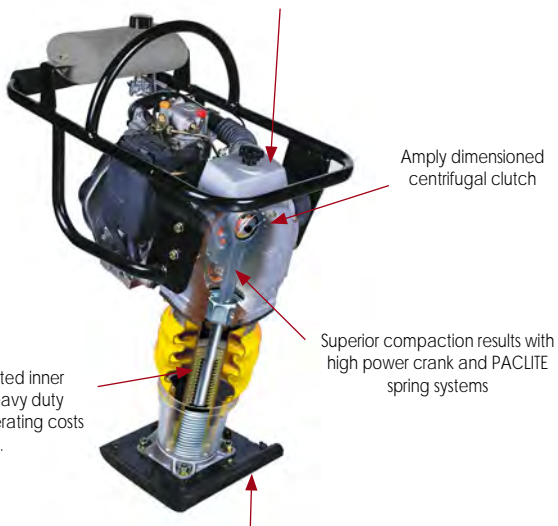

Amplly dimensioned centrifugal clutch

Superior compaction results with high power crank and PACLITE spring systems

The nitride-plated inner sleeve and heavy duty springs keep operating costs down.

Faster: High travel speed with improved foot inclination angle, optimized spring systems and low centre of gravity.

Code	TR800D
Model	TR800D
Operating weight (kg)	84
Centrifugal force (kN)	21,4
Plate size (mm)	334 x 285
Engine	Hatz 1B20-V5
Power hp (kW)	4,6 (3,5)
Speed (m/min)	9 - 12
Amplitude (mm)	75 - 85
Frequency (Hz)	12
Sound level dB (A)	92
Vibrations* (m/s <sup>2</sup> )	9,6
* Minimum vibration levels measured to EN500-4	
Certified power SAE J 1349	



### Wheel kit OPTION

Code OP/TR-WHEEL