

CRX698 RAMMER & NEW CRX698 ECOPOWER RAMMER* FULLY ANTI-VIBRATION OPERATOR HANDLE



Work in absolute comfort, low hand-arm vibration, unique in the industry.

The CRX698 is the first low-vibration hand-arm rammer on the market. It has exceptional characteristics such as flexibility, high powerful percussion for perfect stability at work.

Honda GXR120 engines (air-cooled, drive shaft horizontal power take-off, cast iron jacketed cylinder with carburettor diaphragm) enable very high performance.

A unique air filtration system, at three levels: first, a cyclonic filter which that absorbs the raw materials, then an air filter and then the filter in the Honda engine. Its design keeps the engine practically dust-free and gives it a remarkable lifespan.

The sole of the foot is handcrafted from laminated wood and steel, providing flexibility and endurance. The rammer CX698 has a replaceable (patent-pending) one-piece piston with moulded Teflon trim that doubles its life.

FEATURES AND BENEFITS

- Remarkable flexibility and working comfort.
- Cyclone air pre-filter for five times less maintenance intervals.
- Automatic oil level control.
- Easy access points for engine maintenance.
- Anti-vibration handle, the lowest vibration rate in the labour force industry.
- Engine speed indicator and hour meter.
- Protective cover fitted with a tachometer.
- Central sling ring.
- Wheels mounted on the drawbar for loading.
- Engine stop integrated on the handle.
- 380 mm narrow frame.
- Bellow and foot of German fabrication.
- Honda GXR120 engines.
- Available with battery motor EGX HONDA.
- Machine delivered with charger.
- **Option: EGX Honda battery.**

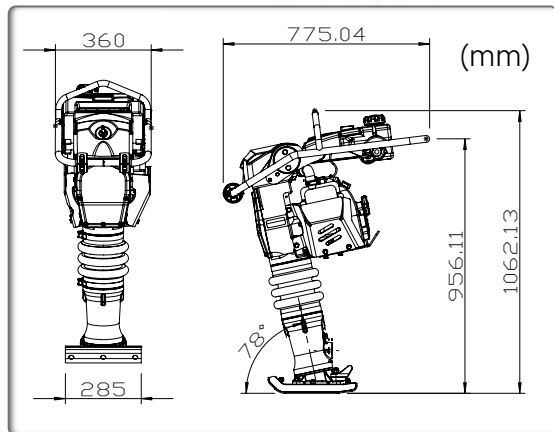

Interchangeable rammer shoe

Code	CRX698	CRX698-ECO
Model	CRX698-4 HONDA	CRX698 ECOPOWER
Operating weight (kg)	68	71
Plate width (mm)	335-285	335-285
Engine	Honda GXR120	Honda EGX
Power hp (kW)	3,1 (2,3)	2,4 (1,8)
Engine speed (rpm)	3600	3600
Cylinder (cm³)	121	-
Consumption of fuel (l/h)	1,1	-
Speed (m/min)	8 - 15	8 - 15
Amplitude (mm)	70 - 85	70 - 85
Frequency (Hz)	12	12
Centrifugal force (kN)	18	18
Sound pressure level dB (A)	104	45
Percussion rate max. (blows/min)	640	640
Operating speed (m/min)	8,9	8,9
Surface capacity compaction (m²/h)	149	149
Vibration emission value* (m/s²)	3,2	6,5
CO2 (NRSC) (g/kWh)	655	-
Hand-arm vibration* (m/s²)	3,1	6,2

* Minimum vibration levels measured to EN500-4
Certified power SAE J 1349

OPTIONS		
Code	CR/SHOE-170	OP/TR-WHEEL
Model	Interchangeable rammer shoe 170 x 135 mm	Transport wheel kit



Wheel kit OPTION



Tachometer



Cyclone filter

COMPACTOR

MOBILE EQUIPMENT

CONCRETE EQUIPMENT

SURFACING

CUTTING - GRINDING