

★ CERTIFICAT DE CONFORMITE ★

CONFORMITY CERTIFICATE ~ CERTIFICADO DE CONFORMIDAD ~ INSTEMMING VERKLARING ~ KONFORMITÄTS BESCHEINIGUNG
KONFORMITETS BEVIS ~ CERTIFICATO DE CONFORMIDADE ~ ATIKTIKTES DEKLARACIJA ~ CERTYFIKAT ZGODNOŚCI ~ СЕРТИФИКАТ
СООТВЕТСТВИЯ ~ CERTIFICAT DE CONFORMITATE ~ СЕРТИФИКАТ ЗА СЪОТВЕТСТВИЕ.

UNI-CORP EUROPE / PACLITE-EQUIPMENT

12 rue des Coquelicots
94380 Bonneuil-sur Marne FRANCE.

☎ +33 (0) 1 49 56 02 82 📠 +33 (0) 1 43 99 19 50

🌐 www.paclite-equip.com

certifie que la machine spécifiée

hereby certify that the equipment specified bellow ~ certifica que la máquina especificada ~ Bescheinigt, dass da Gerät angegebenen ~
bescheinigt, daß das Baugerät bekræfter, at følgende maskine ~ certifica que o equipamento especificação ~ šiuo sertifikatu patvirtina,
kad žemiau nurodytas prietaisas, t.y. Zaświadcza, że wyszczególniona maszyna ~ Подтверждает, что нижеописанная машина
Certifica si declara ca echipamentul mentionat mai jos ~ Потвърждаваме, че оборудването, описано по-долу, потвърдите да је
navedeni stroj.

**MULTIVIB, FUZ, VX PREMIUM , VX BOOSTER, VX D,
SYNCHROMASTER, SYNCHROMASTER-D, VVL200, MONOBLOC, SYNCHRO-S, BOXTECH.**

Est produit conforme aux dispositions des directives,

has been manufactured according to the following standards ~ es de conformidad con todas las disposiciones y directivas ~
in übereinstimmung mit folgenden richtlinien hergestellt ~ é fabricado conforme as seguintes normas ~ buvo pagamintas
laikantis toliau išvardintų standartų została wyprodukowana zgodnie z następującymi normami ~ Произведена в
соответствии со следующими нормами este fabricat cu respectarea urmatoarelor standarde ~ e произведено в
съответствие със следните стандарти ~ je izrađen u skladu s sljedećim propisima ~ je u skladu sa svim odredbama i direktivama ~

**2006/42/CE, 2014/35/UE, 2014/30/UE, 2000/14/CE, 2002/44/CE, 2011/65/UE,
2002/96/CE, EN 60745-2-12:2009, EN 60745-1:2009 + AC:2009 + A11:2010, EN ISO 12100- 1/2:2004**

Total Quality assurance system: CERTIFICATION MANAGEMENT



SYSTEM Standard: UNE-EN-ISO 9001:2015

Certificate N°: 1895/20

RoHS Compliant 2011/65UE

Issued on 4th October 2006

Valid until 02nd September 2024

Technical manager

Polinya(España)2023



TYPES / MODELS

BOXTECH-3M

230V 50/60 Hz



- (E) Manual del Operador
- (GB) Operators Manual
- (F) Manuel De L'Opérateur
- (S) Bruksanvisning
- (PL) Instrukcja Obsługi
- (RUS) Руководство для оператора
- (LT) Naudojimo Instrukcija
- (RO) Manual de Utilizare
- (NO) Betjene Håndbok
- (CZ) Na'vod K Obzluze
- (D) Bedienungshandbuch
- (BG) Оператор Ръчен



EP3M-23/03



* SEGURIDAD ELECTRICA * ELECTRICAL SAFETY * SECURITE ELECTRIQUE *
 ELEKTRISK SAKERHET * BEZPIECZENSTWO ELEKTRYCZNE *
 ЭЛЕКТРИЧЕСКАЯ БЕЗОПАСНОСТЬ * DARBO SU ELEKTRINIAIS *
 SIGURANTA ELECTRIC * ELEKTRISK SIKKERHET * ELEKTRICKYM NARADIM
 * ELEKTRISCHE SICHERHEIT * ЭЛЕКТРИЧЕСКА БЕЗОПАСНОСТ *

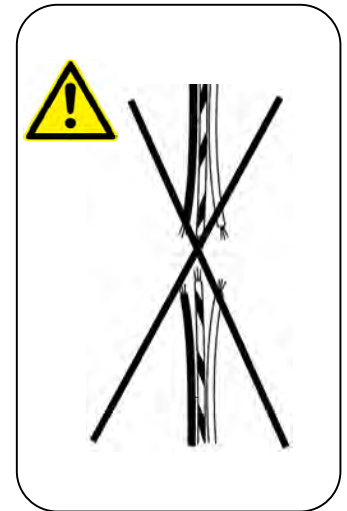
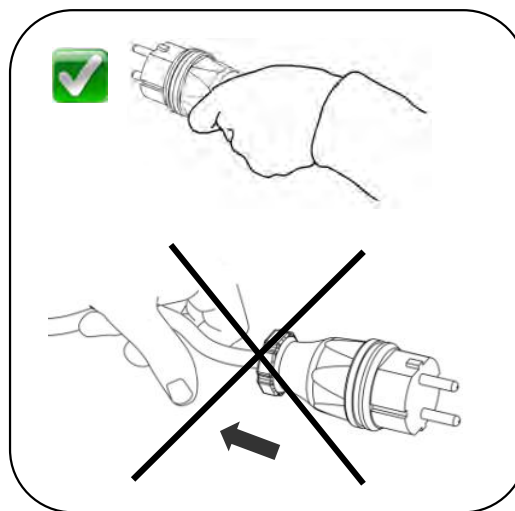
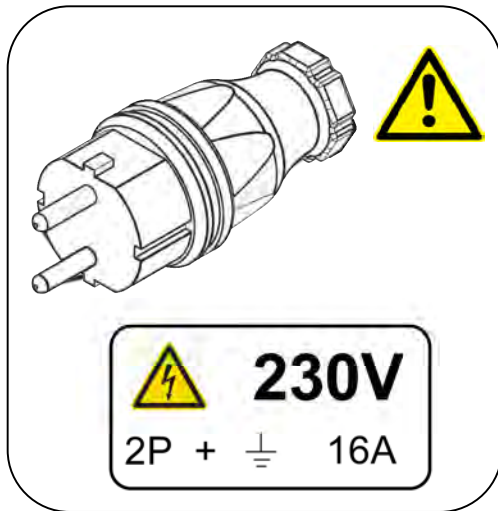

- *Precaución: Red con toma tierra
- *Warning: Grounding electrical network
- *Attention: Réseau électrique à la terre
- *Varning: Elnätet elektrisk jordning
- *Uwaga: Sieć elektryczna uziemienia
- *Внимание: сети электрического заземления
- *Atsargiai: Maitinimo elektros įžeminimo
- *Atenție: Rețea de împământare electrică
- *Advarsel: Stikkontakt grunnstøting
- *Upozornění: Napájecí elektrické uzemnění
- *Achtung: Netz elektrischen Erdung
- *Внимание: электрическата мрежа електрически заземяване



PROTEGIDO * PROTECTED * PROTÉGÉ * SKYDDAD * OCHRONNY * ОХРАНЯЕМЫХ * SAUGOMA *
*** PROTEJATE * BESKYTTET * CHRÁNĚNÉ * GESCHÜTZT * ЗАЩИТЕНИ ***



AUSENCIA TOMA TIERRA
 ABSENCE GROUNDING CONNECTION
 Mise à la terre L'ABSENCE
 FRĀNVARO JORDNING ANSLUTNING
 Uziemieniem BRAKU
 ОТСУТСТВИЕ заземления
 NEDARBINGUMAS dangai susijungian
 Absenta împământare connection
 FRAVÆR JORDING TILKOBLING
 ABSENCE uzemnění
 KEINE Erdung
 Липсата ЗАЗЕМЯВАНЕ ВРЪЗКА

TENSION E INTENSIDAD
 VOLTAGE AND CURRENT
 TENSION ET COURANT
 Spännings-och
 NAPIĘCIA I PRĄDU
 Напряжение и ток
 Įtampos ir srovės
 De tensiune și curent
 Spenning og strøm
 NAPĚTÍ A PROUDU
 SPANNUNG UND STROM
 Напрежението и тока

SOBRECALENTAMIENTO
 OVERHEATING
 SURCHAUFFE
 ÖVERHETTNING
 PRZEGRZANIA
 ПЕРЕГРЕВА
 Perkaitimas
 SUPRĂÎNCĂLZIRE
 OVEROPPHETING
 PŘEHŘÁTÍ
 ÜBERHITZUNG
 ПРЕГРЯВАНЕ



* MEDIO AMBIENTE * ENVIRONMENT * ENVIRONNEMENT * MILJÖ *
ŚRODOWISKO * ОКРУЖАЮЩЕЙ СРЕДЫ * APLINKA * MEDIU * MILJØ * ZIVOTNI
PROSTREDI * UMWELTSCHUTZ * ОКОЛНАТА СРЕДА *

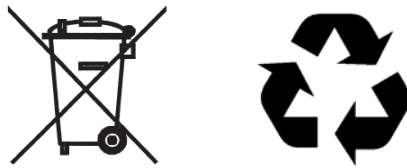

SEGURIDAD GENERAL * GENERAL SAFETY * GENERALE DE SECURITE *
* ALLMÄN SÄKERHET * BEZPIECZEŃSTWA * ОБЩАЯ БЕЗОПАСНОСТЬ
* BENDROSIOS SAUGOS * SIGURANTA * GENERELL SIKKERHET * OBECNE
BEZPECNOSTNI POKYNY * ALLGEMEINE SICHERHEIT * ОБЩИ БЕЗОПАСНОСТ *



* AREA DE TRABAJO * WORK AREA * ZONE DE TRAVAIL *
ARBETSOMRADE * OBSZAR ROBOCZY * РАБОЧЕЕ МЕСТО * DARBO
VIETA * ZONA DE LUCRU * ARBEIDSOMRADE * PRACOVISTE *
ARBEITSUMFELD * РАБОТНОТО МЯСТО *



QUICK VIEW *



ASA
Handle.

BASE CONEXION
Outlet socket

TAPA CONVERTIDOR
Steel plate housing cover

CLAVIJA CONEXION
Connection Plug

POKER CONNECTIONS:
VX-PREMIUM/VX-BOOSTER

* OPERATIVA * OPERATION * FONCTIONNEMENT * DRIFT
 * PRACA URZADZENIA * РАБОЧИЕ * NAUDOJIMAS * UTILIZAREA * BRUK
 * POKYNY PRO PROVOZ * HANDHABUNG * ОПЕРАТИВНА *



1

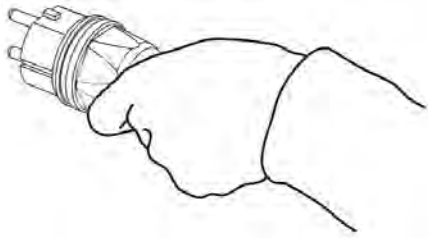

230V / 50 Hz

2

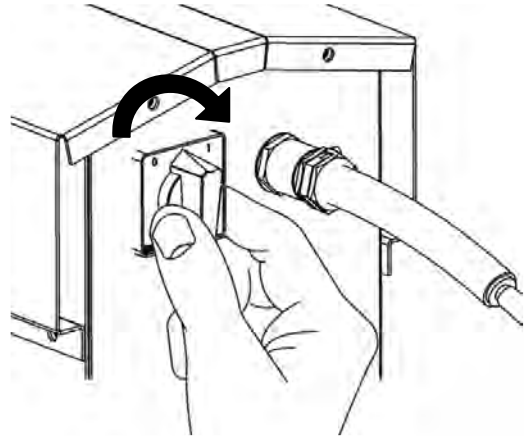

3

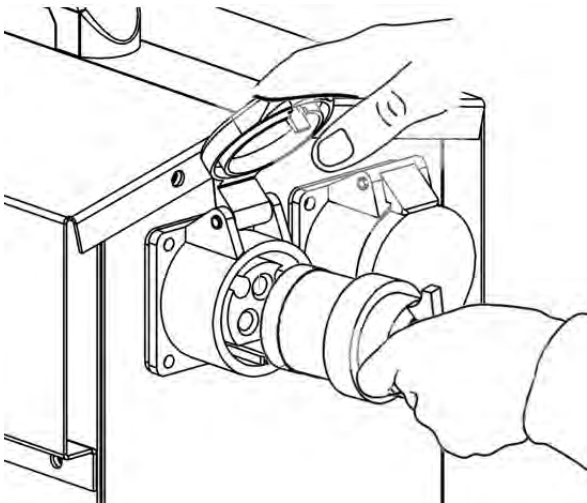

4

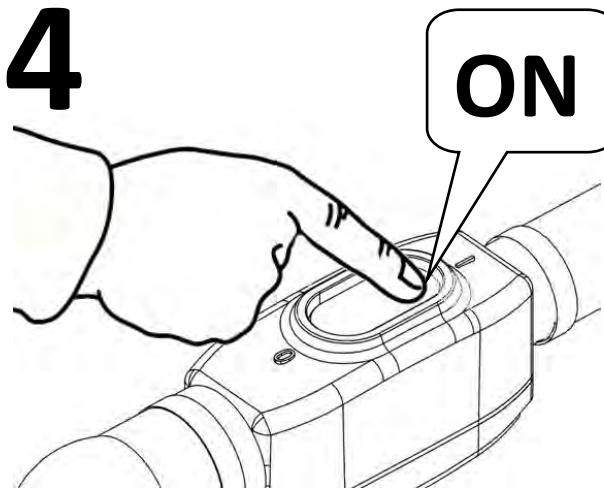

PACLITE **P** CE

UNI-CORP EUROPE / PACLITE-EQUIPMENT
 12 rue des Coquelicots
 94380 Bonneuil-sur Marne FRANCE

BOXTECH-3M IP44-57

INPUT
 230V - 50/60Hz - 12A / 1Ph

OUTPUT
 42V / 200Hz - 30A / 3Ph
 2,5 kVA

CODE
 PACLI10171

3x42V/200Hz

DATE:
 07/07/23

SERIAL N°: 7992310171011162

PACLITE **P** CE

UNI-CORP EUROPE / PACLITE-EQUIPMENT
 12 rue des Coquelicots
 94380 Bonneuil-sur Marne FRANCE

BOXTECH-3M IP44-57

CODE
 PACLI10171

3x42V/200Hz

SERIAL N°: 7992310171011162

INPUT
 230V - 50/60Hz - 12A / 1Ph

OUTPUT
 42V / 200Hz - 30A / 3Ph
 2,5 kVA

DATE:
 07/07/23

CAUTION

VX40-PREMIUM VX-BOOSTER 40	3
VX45-PREMIUM VX-BOOSTER 45	3
VX51-PREMIUM VX-BOOSTER 52	3
VX58-PREMIUM VX-BOOSTER 58	2
VX65-PREMIUM VX-BOOSTER 65	1
VX75-PREMIUM VX-BOOSTER 75	1

MAXIMUM RECOMENDED POKER CONNECTIONS

CE **PACLITE** **P**

* SERVICIO Y MANTENIMIENTO * SERVICE AND MAINTENANCE * ENTRETIEN ET REVISION * SERVICE & UNDERHALL * SERWIS I KONSERWACJA * СЕРВИС И ОБСЛУЖИВАНИЕ * TECHNINE PRIEZIURA * SERVICE SI INTRETINERE * SERVICE OG VEDLIKEHOLD * SERVIS A UDRZBA * SERVICE AND WARTUNG * ОБСЛУЖВАНЕ И ПОДДЪРЖАНЕ *

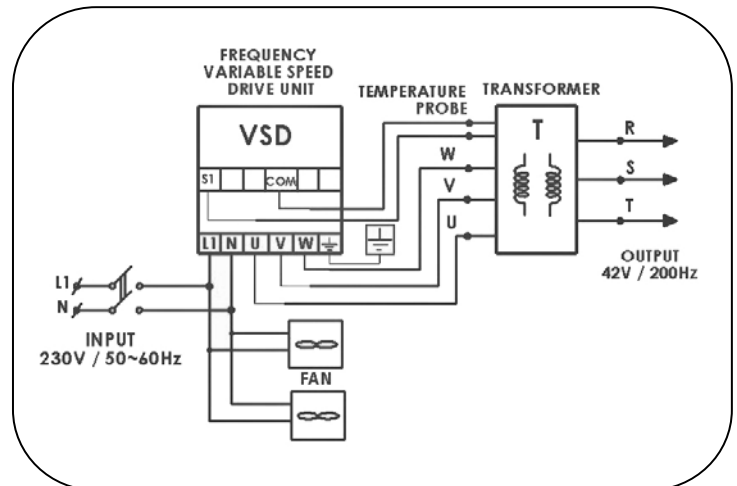
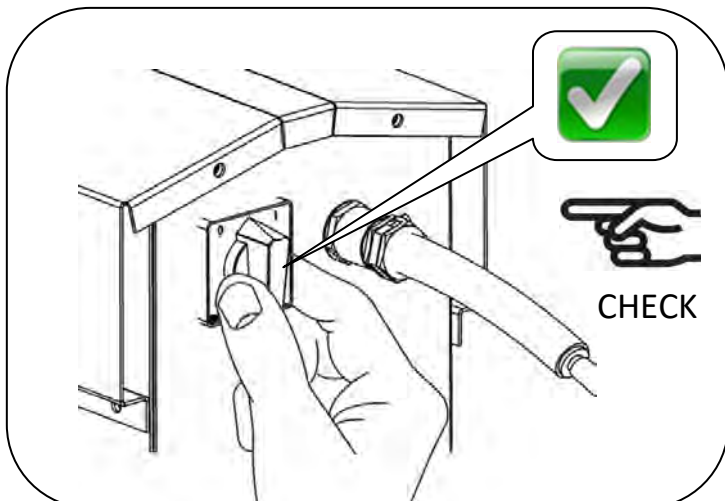
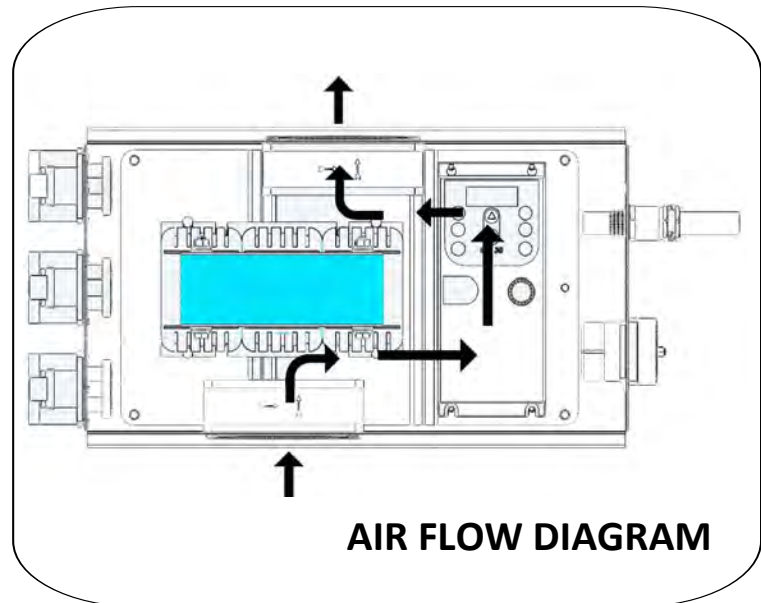
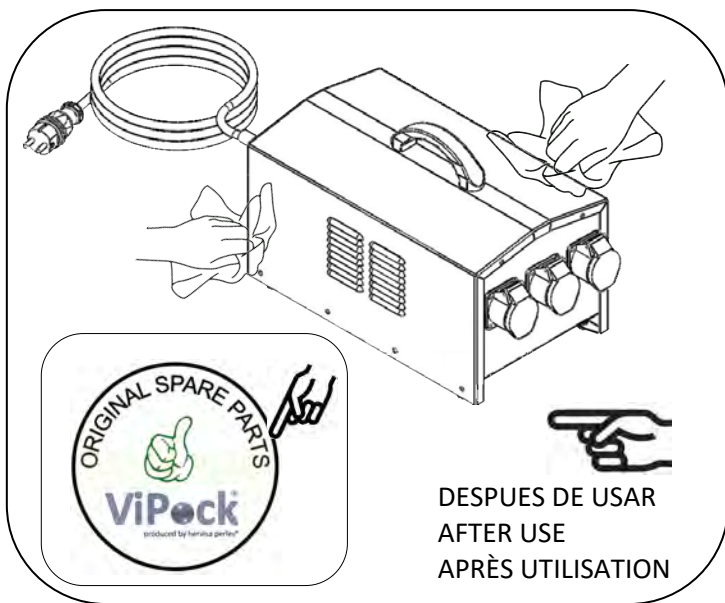
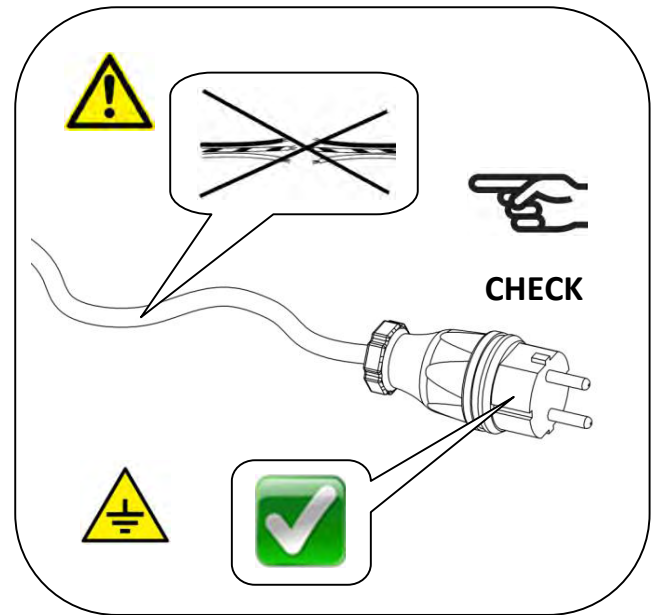
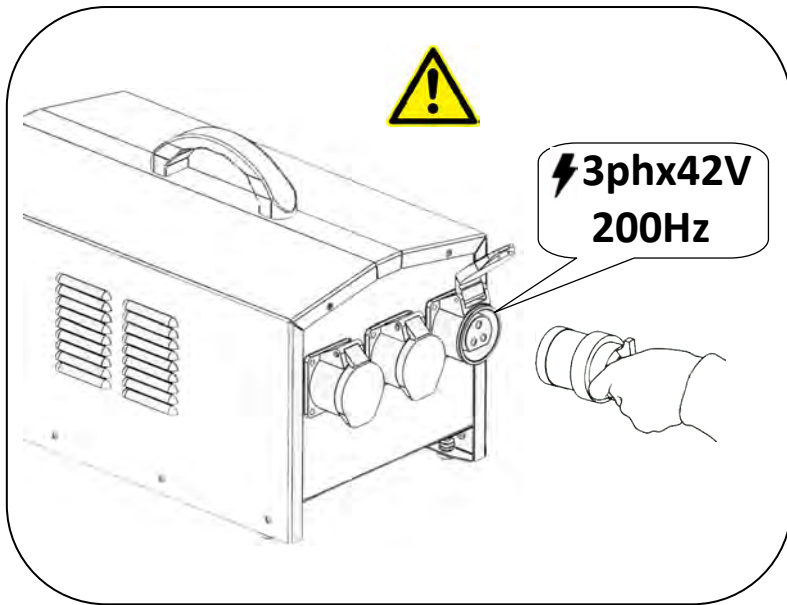

* ALMACENAJE Y TRANSPORTE * STORAGE & TRANSPORTATION * STOKAGE & TRANSPORT * FÖRVARING & TRANSPORT * PRZECHOWYWANIE & TRANSPORT
 * ТРАНСПОРТ * LAIKYMAS & TRANSPORTAVIMAS * DEPOZITAREA & TRANSPORTAREA * LAGRING OG TRANSPORT * SKLADOVANI A PREPRAVA * LANGERUNG & TRANSPORT * СЪХРАНЕНИЕ И ТРАНСПОРТ *

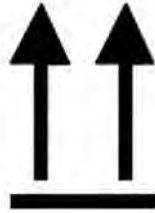

* GARANTIA * WARRANTY * GARANTIE * GARANTI * GWARANCJA * ГАРАНТИЯ
 * GARANTIJA * GARANTIA * GARANTI * ZARUKA * GARANTIE * ГАРАНЦИЯ *



WARRANTY



CONDICIONES DE GARANTIA EN RESTO DE PAISES CONSULTE CON SU DISTRIBUIDOR.

WARRANTY TERMS OTHER COUNTRIES CHECK WITH YOUR LOCAL DEALER.

TERMES DE LA GARANTIE D'AUTRES PAYS VÉRIFIEZ AVEC VOTRE REVENDEUR LOCAL.

GARANTIVILLKOREN ANDRA LÄNDER KONTROLLERA MED DIN LOKALA ATERFÖRSÄLJARE.

WARUNKI GWARANCJI INNYCH KRAJÓW SPRAWDŹ Z LOKALNYM SPRZEDAWCA.

УСЛОВИЯ ГАРАНТИИ ДРУГИЕ СТРАНЫ Проверьте с вашим местным дилером.

GARANTIJOS SĄLYGOS KITŲ ŠALIŲ PATIKRINTI SU SAVO VIETOS ATSTOVAS.

TERMENI DE GARANȚIE ALTE ȚĂRI Consultați-vă CU DISTRIBUITORUL LOCAL.

GARANTIBETINGELSENE ANDRE LAND SJEKK MED DIN LOKALE FORHANDLER.

ZÁRUČNÍ PODMÍNKY DALŠÍ ZEMĚ Poradte se s místními prodejci.

GARANTIEBEDINGUNGEN ANDERE LÄNDER PRÜFEN VON IHREM HÄNDLER.

ГАРАНЦИОННИ УСЛОВИЯ В ДРУГИ ДЪРЖАВИ: Консултирайте се с вашия местен дилър.

WARRANTY SERVICES



Mano de obra y piezas por defecto de fabricación

Labor and parts for manufacturing defects

Travail et de pièces pour des défauts de fabrication

Arbete och delar för tillverkningsfel

Pracy i części do wad fabrycznych

Труда и детали для производственных дефектов

Darbo ir dalys gamybos defektų

Forței de muncă și piese pentru defecte de fabricație

Arbeid og deler for produksjonsfeil

Práce a dílů pro výrobní vady

Arbeitszeit und Teile für Fabrikationsfehler

Покрива труда и частите за фабрични дефекти



BOXTECH-3M

Spare parts / Repuestos

VERSION	CODE
BOXTECH-3M	10171

INPUT 1ph 230V/50-60Hz
OUTPUT 3 X 42V/200Hz

