



# MD 500-S



Operator's Manual



## Crawler Mini Dumper

# EC DECLARATION OF CONFORMITY / DECLARATION CE DE CONFORMITE / DECLARACIÓN DE CONFORMIDAD CE / DECLARAÇÃO CE DE CONFORMIDADE / ДЕКЛАРАЦИЯ О СООТВЕТСТВИИ ЕС / EC DECLARAȚIE DE CONFORMITATE

GB/US

We **Uni-corp Europe, PACLITE EQUIPMENT 12 AVENUE DES COQUELICOTS 94380 BONNEUIL SUR MARNE , France, France**, hereby certify that if the product described within this certificate is bought from an authorised Paclite dealer within the EEA, it conforms to the following directives: Machinery Directive 2006/42/EC, Electromagnetic Compatibility Directive 2004/108/EC (as amended by 92/31/EEC & 93/68 EEC). The physical agent (vibration) conforms with the directive 2002/44/EC. The low voltage directive 2006/95/EC, BS EN ISO 12100-1/2 Safety of machinery and associated harmonised standards, where applicable. Noise emissions conform to directive 2005/88/EC Annex VI), for machines under article 12 the notified body is **TÜV Rheinland Product Safety GmbH - Am Grauen Stein - D-51105 Köln, Germany**.

F

Nous soussignons, **Uni-corp Europe, PACLITE EQUIPMENT 12 AVENUE DES COQUELICOTS 94380 BONNEUIL SUR MARNE , France**, certifions que si le produit décrit dans ce certificat est acheté chez un distributeur de la marque déposée "Paclite" au sein de la EEA, celui-ci est conforme aux norms CEE ci-après: Norme de la machine 2006/42/CE, Norme compatible pour l'électromagnétisme 2004/108/CE (modifié par 92/31/CEE et 93/68/CEE). Le nombre de vibrations est en accord avec la directive 2002/44/CE. Caractéristiques basse tension 2006/95/CEE, BS EN ISO 12100-1/2 , Norme de sécurité des machines et des critères associés et configurés, si applicable. Les émissions de bruit sont conformes à la directive 2005/88/CE Annexe VI pour machines, article 12. L'objet mentionné est **TÜV Rheinland Product Safety GmbH - Am Grauen Stein - D-51105 Köln, Allemagne**.

E

La Sociedad, **Uni-corp Europe, PACLITE EQUIPMENT 12 AVENUE DES COQUELICOTS 94380 BONNEUIL SUR MARNE , France**, por el presente documento certifica que si el producto descrito en este certificado es comprado a un distribuidor autorizado de Paclite en la EEA, este es conforme a las siguientes directivas: 2006/42/CE de la CEE, Directiva 2004/108/CEE sobre Compatibilidad Electromagnética (según enmiendas 92/31/CEE y 93/68/CEE). El numero de vibraciones esta de acuerdo con la Directiva 2002/44/CE. Directiva sobre Bajo Voltaje 2006/95/CEE, BS EN ISO 12100-1/2 de Seguridad de Maquinaria y Niveles armonizados estándares asociados donde sean aplicables. Emisión de Ruidos conforme a la Directiva 2005/88/CE Anexo VI para máquinas bajo artículo 12 la mencionada unidad está **TÜV Rheinland Product Safety GmbH - Am Grauen Stein - D-51105 Köln, Germany**.

P

O signatário, **Uni-corp Europe, PACLITE EQUIPMENT 12 AVENUE DES COQUELICOTS 94380 BONNEUIL SUR MARNE , France**, pelo presente, declara que se o produto descrito neste certificado foi adquirido a um distribuidor autorizado do Paclite em qualquer país da EEA, está em conformidade com o estabelecido nas seguintes directivas comunitárias: 2006/42/CE, Directiva de Compatibilidade Electromagnética 2004/108/CEE (conforme corrigido pelas 92/31/EEC & 93/68 EEC). O numero de vibrações está de acordo com a directiva 2002/44/CE LB. A directiva de baixa voltagem 2006/95/CEE, BS EN ISO 12100-1/2 Segurança da maquinaria e às normas harmonizadas afins se aplicáveis. As emissões de ruído respeitam e estão dentro das directivas para máquinas 2005/88/CE Anexo VI, artigo 12, sendo o organismo notificado **TÜV Rheinland Product Safety GmbH - Am Grauen Stein - D-51105 Köln, Germany**.

RUS

Мы, компания **Uni-corp Europe, PACLITE EQUIPMENT 12 AVENUE DES COQUELICOTS 94380 BONNEUIL SUR MARNE , France, France**, настоящим подтверждаем, что если упомянутая в настоящей декларации продукция приобретена у уполномоченного представителя Paclite в Европейской экономической зоне, она отвечает требованиям перечисленных ниже директив: Директива по машиностроению 2006/42/ЕС, Директива о электромагнитной совместимости 2004/108/ЕС (с добавлениями 92/31/ЕЕС и 93/68 ЕЕС). Рабочее воздействие (вибрация) соответствует требованиям Директивы 2002/44/ЕС. Директива о низковольтном оборудовании 2006/95/ЕС, BS EN ISO 12100-1/2 Гармонизированные стандарты по безопасности машин и связанные с ними другие гармонизированные стандарты (где применимо). Шумовое воздействие в соответствии с директивой 2005/88/ЕС Приложение VI). Для машин, соответствующих требованиям статьи 12, уполномоченным органом является **TÜV Rheinland Product Safety GmbH – Am Grauen Stein – D- 51105 Köln, Germany**.

RO

Noi, **Uni-corp Europe, PACLITE EQUIPMENT 12 AVENUE DES COQUELICOTS 94380 BONNEUIL SUR MARNE , France**, prin prezenta certificăm că produsul descris în acest certificat și cumpărat de la un distribuitor autorizat Paclite din EEA, este realizat în conformitate cu următoarele directive: Directiva pentru echipamente 2006/42/EC, Directiva privind compatibilitatea electromagnetică 2004/108/EC (modificată conform 92/31/EEC & 93/68 EEC). Agentul fizic (vibrația) este conform cu directiva 2002/44/EC. Directiva pentru curenți mici 2006/95/EC, BS EN ISO 12100-1/2 Siguranța echipamentelor și asociată standardelor armonizate, unde este aplicabil. Emisiile de zgomot conform directivei 2005/88/EC Annex VI), pentru echipamente la articolul 12 certificată de **TÜV Rheinland Product Safety GmbH - Am Grauen Stein - D-51105 Köln, Germania**.

PRODUCT TYPE.....	TYPE DE PRODUIT....	TIPO DE PRODUCTO..	TIPO DE PRODUCTO..	ТИП ИЗДЕЛИЯ.....	TIP PRODUS.....
MODEL.....	MODELE.....	MODELO.....	MODELO.....	МОДЕЛЬ.....	MODEL.....
SERIAL No.....	Nº DE SERIE.....	Nº DE SERIE.....	Nº DE SÉRIE.....	СЕРИЙНЫЙ №.....	SERIE .....
DATE OF	DATE DE	FECHA DE	DATA DE	ДАТА	DATA
MANUFACTURE.....	FABRICATION.....	FABRICACIÓN.....	FABRICO.....	ИЗГОТОВЛЕНИЯ...	DE PRODUCTIE.....
WEIGHT.....	POIDS.....	PESO.....	PESO.....	МАССА.....	GREUTATE.....



Signed by:   
 Signature:  
**Anita Tan**

Quality Manager - On behalf of Uni-corp Europe  
 Directrice de Qualité - au nom de Uni-corp Europe S.A.R.L.

# Foreword

This manual has been written to help you operate the Paclite MD 500s safely. It is intended primarily for dealers and operators of Paclite equipment. It is recommended that you keep this manual or a copy of it with the machine so that it is readily available for reference.

Before you operate or carry out any maintenance on this machine YOU MUST READ and UNDERSTAND this manual.

Should you have ANY QUESTIONS about the safe use or maintenance of this machine after reading this manual, ASK YOUR SUPERVISOR or CONTACT:

Uni-corp Europe on +33 (0) 1 4981 6955

Paclite reserves the right to change machine specification without prior notice or obligation.

## Directions with regard notations

Text in this manual to which special attention must be paid are shown in the following way:



**CAUTION**

This CAUTION sign indicates a potential hazard, which if ignored, could result in injuries to the operator and/or those close by, as well as damaging the machine.



**WARNING**

This WARNING sign indicates a potential hazard, which if ignored could result in the DEATH of the operator and/or those close by.

# Contents

Foreword .....	2
Safety Information.....	3-5
Environment.....	5
Machine Description.....	6
Pre-Start Checks.....	7
Start And Stop Procedure .....	7-8
Operation.....	9
Service and Maintenance.....	9-10
Transportation And Storage .....	10-11
Trouble Shooting.....	12
Technical Data.....	12
Warranty .....	13



## Safety Information

For your own personal protection and for the safety of those around you, please read and ensure you fully understand the following safety information. It is the responsibility of the operator to ensure that he/she fully understands how to operate this equipment safely.



**CAUTION**

Improper maintenance can be hazardous. Read and understand this section before you perform any maintenance, service or repairs.

If you are unsure about the safe and correct use of the MD 500s, consult your supervisor or Paclite Equipment.

## General Safety

### Understanding Your Machine

- Read & understand the operator's manual and learn its application and limitation as well as the specific potential hazards peculiar to it.
- Be familiar with the controls and its functions. Know how to stop the machine and disengage the controls quickly.

### Work Area

- Never start or run the machine inside a closed area. The exhaust fumes are dangerous.



**WARNING**

The exhaust fumes produced by this machine are highly toxic and can kill!

- Operate this unit only in well ventilated outdoor area.
- Never operate the machine without good visibility or light.

### Personal Equipment

- Use safety equipment to reduce personal injuries.
- Check your machine before starting it. Make sure all nuts, bolts, etc are securely tightened.
- Never operate the machine when it is in need of repair or is in poor condition. Replace damaged, missing or failed parts before using it.
- Always stop the engine and allow it to cool before filling the fuel tanks. Never remove the cap of the fuel tank or add fuel while the engine is hot.

## Fuel Safety



**WARNING**

Fuel is flammable. It may cause injury and property damage. Shut down the engine, extinguish all open flames and do not smoke while filling the fuel tank. Always wipe up any spilled fuel.

- Before re-fuelling, switch off the engine and allow it to cool.
- When re-fuelling, use a proper funnel, and avoid spilling over the engine.
- When re-fuelling, DO NOT smoke or allow naked flames in the area.
- Spilt fuel must be made safe immediately by using sand. If fuel is spilt on your clothes, change them.
- Store fuel in an approved, purpose made container away from heat and sources of ignition.

## Machine Use & Care

- Position the machine in such a way that it cannot move during maintenance, cleaning, adjustment or assembly of accessories or spare parts as well as under storage.
- Do not run the machine in high speed when you are not working.
- If the machine should start to make an unusual noise or vibration, immediately shut down the engine and check for the cause.
- Keep all bystanders, childrens and pets at least 23m (75 feet) away. If you are approached, stop the unit immediately.
- Never park the machine in a place with unstable ground.
- Never leave the operating position when the engine is running.
- Always hold the unit with both hands when operating. Be aware that the machine may unexpectedly bounce upward or jump forward.
- Do not overload the machine capacity. Drive at safe speed. Adjusting the speed to the slope of the surface condition & the weight of the load.
- Do not operate the machine in confined areas where they may be risk of crushing the operator between the machine and other object.
- Never operate the machine on slopes where angle is over 15 degree.

## General Driving

- Do not operate machine under the influence of alcohol or drugs. Do not operate machine when you are tired, ill, or not fit to operate machine.
- On a slippery surface, travel slowly and exercise caution to reduce the chance of skidding or sliding out of control. Never operate on ice.



- To reduce the risk of tipping over, pay special attention when encountering an obstacle or a slope, or when braking on a slope or during a turn.
- Never attempt to drive over a large obstacle such as rock or fallen tree.
- Never operate on terrain that you are not comfortable with. Avoid terrain that is so rough, slippery or loose that you feel like you could tip over.
- Use an observer to help direct machine when visibility is poor, terrain is rugged or hilly, or maneuvering room is limited. An observer should be able to see machine and its immediate surrounding and should give pre-arranged signals to direct the operator.

### **Driving On A Slope/Downhill**

- When carrying no load, do NOT use machine on a slope steeper than 20 degrees. When carrying a load, do NOT use machine on a slope steeper than 15 degrees. Observe the load limit according to the inclination. Do not dump on a slope.
- Never drive on a slope that you are not comfortable with. Avoid a slope that is so rough, slippery, or loose that you feel like you could tip over.
- When driving downhill, stop and shift to one of the first three gears (auxiliary transmission in Low). Go down at a reduced speed. Use engine speed to help keep machine speed low.

### **Loading & Driving With A Load**

- The maximum payload for this machine is 500kg. Do not exceed this maximum payload under any circumstance.
- Place a load in loading deck so that the weight is evenly distributed. When carrying a load, strap it to loading deck to prevent it from shifting. Ensure that the load does not obstruct the operator's field of view.
- When carrying a load, drive at a reduced speed. Allow greater distance for braking.
- Before crossing a bridge or an overpass, make certain that the total combined weight of machine, load and operator is within the stated weight limit of the bridge or the overpass. Then, proceed carefully and at a constant speed.

### **Parking**

- Park machine on a flat, level and stable surface. Do not park in a dangerous place.
- Never park machine on a slope steeper than 15 degrees. Avoid parking on a slope less than 15 degrees. If parking on a slope less than 15 degrees is unavoidable, block tracks at the lower end of machine.
- Diesel fuel is highly flammable and can be explosive. When parking machine indoors, make certain that the building is well ventilated and that machine is not close to any source of flame or spark, including appliances with pilot lights.

# Machine Description

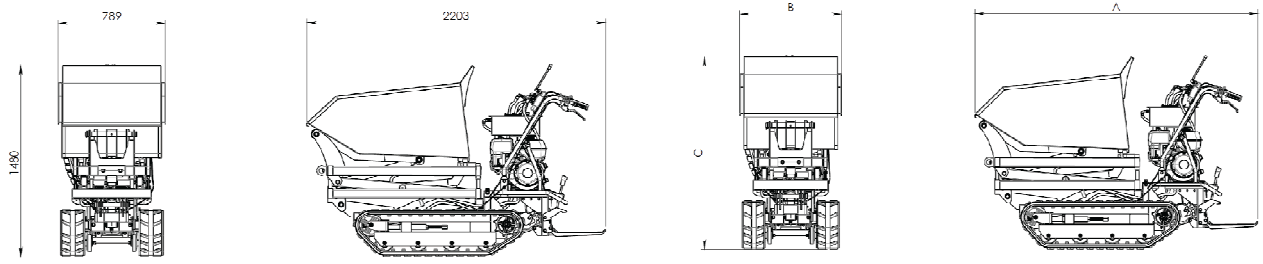
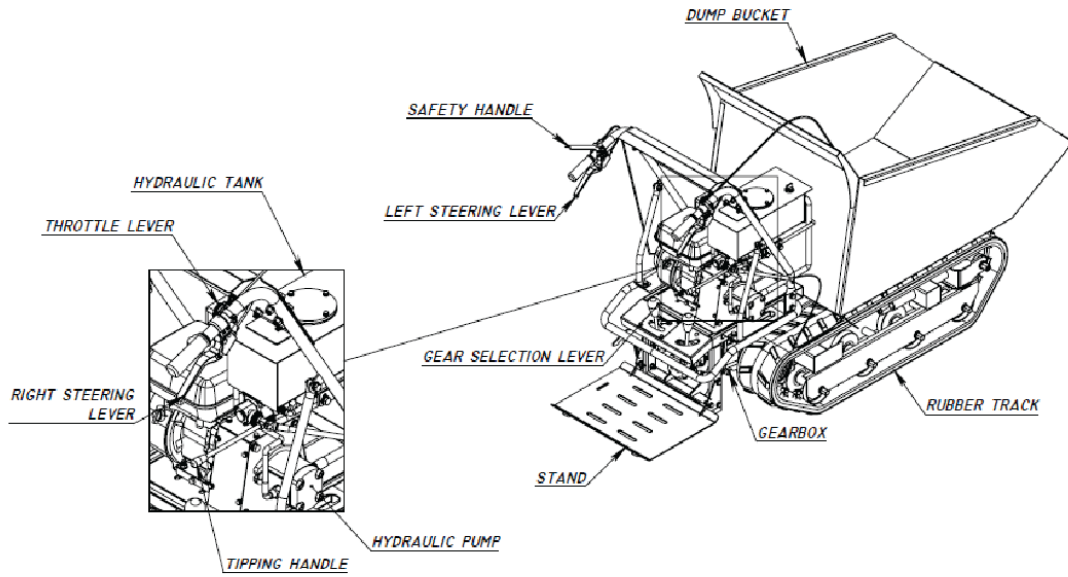

90 mm

<b>MINI DUMPER</b>		
MODEL	WEIGHT	POWER
<b>MD500-S</b>	<b>406 KG</b>	<b>9.0 HP</b>
SERIAL NO	YEAR	<b>CE</b>
<b>XXXXXX</b>	<b>2023</b>	

40 mm

Distributed by:

**PACLITE**  
Equipment

PACLITE EQUIPMENT  
ZAC DES PETITS CARREAUX  
12, AVENUE DES COQUELICOTS  
94300 BONNEUIL SUR MARNE France  
Tel. No : +33 6809 97938  
Website : [kent.gorsun@pac-lite-equip.com](mailto:kent.gorsun@pac-lite-equip.com)

Material : PVC Waterproof Sticker



Model		Foison MD500s	
Machine Weight	kg	406	
Maximum Payload	kg	500	
Dimensions	A - Overall Length	mm	2203
	B - Overall Width	mm	789
	C - Overall Height	mm	1479
	Bucket Size	(W x L x H) mm	785 X 1251 X 858
	Ground Clearance	mm	192
	Step Height	mm	190
	Model	-	VWM 9.0      GX 270
Engine	Engine Type	-	Vibtech V-Power VWM 9.0 (9.0HP)      OHV single-cylinder, 4 stroke (8.4HP)
	Displacement	cc	270
	Compression Ratio	-	8.5 : 1
	Max Revolutions per minute	rpm	3600
	Torque	-	19.1 Nm/1.94 kgfm/2500 rpm
	Fuel Tank Capacity	litre	5.3 liters
	Fuel Consumption	-	2.4 lt/h @ 3600 rpm      2.5 lt/h @ 3600 rpm
Performance	Speed	Forward 1	km/h      2
		Forward 2	km/h      3
		Forward 3	km/h      5
		Reverse	km/h      2

Model		Foison MD500s	
Drive Train	Clutch	-	Driven Pulley
	Steering Mechanism	-	Lever
	Track Width	mm	178
	Transmission Oil Capacity	litre	2
	Gearbox Shift Position	-	3F, 1R
Hydraulic System	Hydraulic Pump	Type	-      Gear Pump
		Max Speed	rpm      3000
	Working Pressure Max	kg/cm <sup>2</sup> (psi)	210 (3000)
		Hydraulic Fluid Capacity	litre
	Tipping Cylinder Bore Size	mm	55 x 35

## Intended Use

This machine is intended for base preparation, driveways, foundations, curbs, and footings. It can also be used for repair work on streets, highways and/or pavements/sidewalks.



# Start and Stop Procedure



**CAUTION**

Improper operation can be hazardous. Read and understand this section before you start the machine.

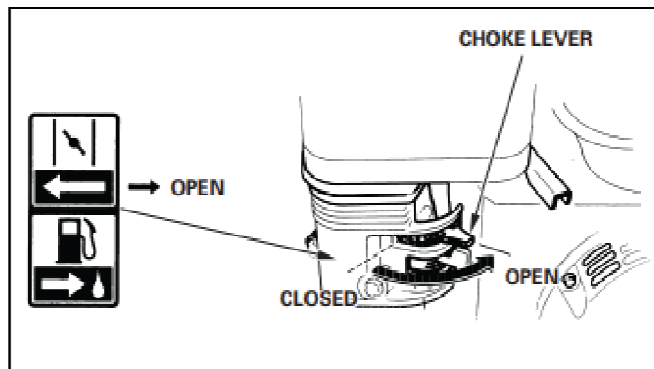

1. Move the fuel valve lever to the ON position.
2. To start a cold engine, move the choke lever to CLOSED position  
\* to restart a warm engine, leave the choke to OPEN position
3. Set the throttle lever on the handlebar at half-way position.
4. Turn the engine switch on.
5. Pull the starting rope slowly several times to allow the gasoline to flow into the engine's carburetor. Pull the rope until the engine starts.
6. Allow the engine to run for several seconds to warm up.

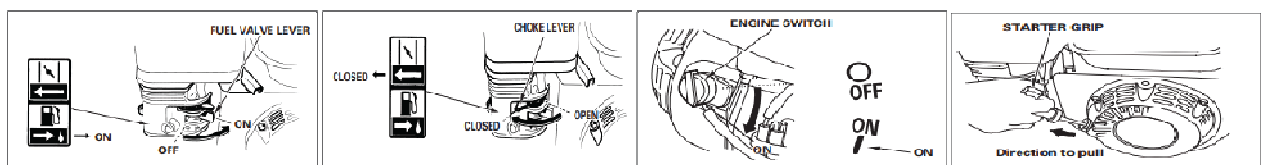

7. If the choke position was moved to CLOSED position to start the engine, gradually move it to the OPEN position as the engine warms up.

Model	Engine	Maximum RPM	
		Optimum	Upper Limit
MD500s	HONDA GX270	3600	4000
	VWM 9.0		

The Max rpm as shown above is the number of ignitions per minute. GX270 & VWM 9.0 engine for the MD500s have the final gears at the ration of 8.5 : 1, and the number of ignitions per minute is different from the number of rotations of the engines Power Take-Off Shaft.

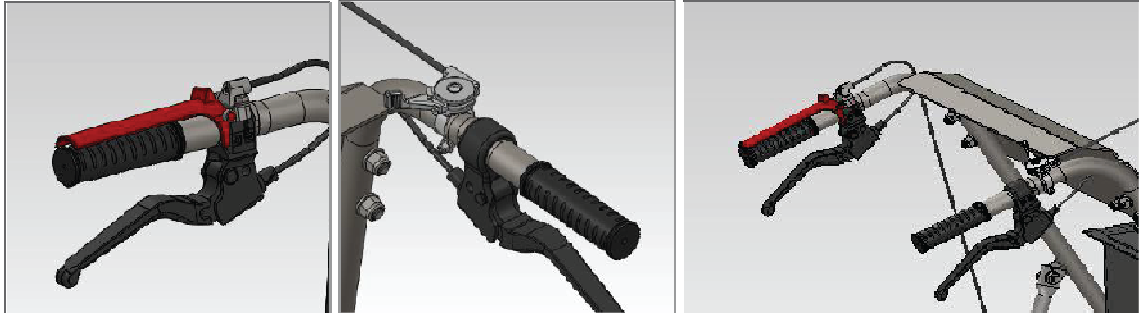

**DO NOT** alter this setting since irregular vibration or damage to the gear transmission mechanism can result, and both engine and machine warranties will be automatically voided.

Having carried out the check in the 'Pre-Start' section, you may now start the engine.

## Operation

- After engine warms up, slowly squeeze the clutch control lever, then engage the required gear. If the gear does not engage straight away, slowly release the clutch lever and try again.
- Pull throttle lever to accelerate engine speed.
- Control the direction, left or right, using the steering lever on the handle bars.

### Operation (Driving)

- The steering levers are on the handlebars. To turn right or left, simply operate the corresponding right or left steering lever.
- The sensitivity of the steering increase in proportion to the speed of the machine, a light pressure on the lever is all that is needed to turn.
- The machine has a maximum capacity of 500kg. However, it is advisable to assess load and adjust it according to the ground on which the machine will be used.
- Avoid sharp turns and frequent changes of direction while driving on the road, in particularly on rough, hard terrains full of sharps, uneven points with a high degree of friction.
- The sticker marking indicates the throttle lever where the engine ramp rate and machine noise can be controlled by the user to their desired level.

- It is on the user's responsibility to ensure if the throttle level exceeds the recommended maximum level, he should always wear ear plugs during the operation.



### Operation (Parking)

- Always park on a firm, level ground. Never park on a potentially dangerous place.
- Avoid parking on a slope. Never park on a slope with an incline of 15 degree or higher. If it is absolutely necessary to park machine on a slope less than 15 degrees, make a certain to apply parking brake firmly.

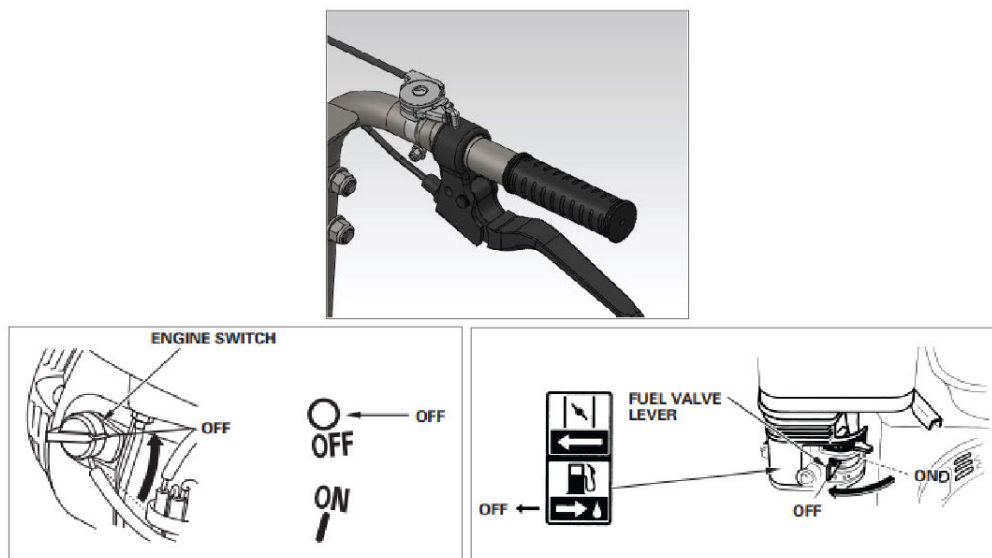

1. Slow the throttle level to decrease the engine speed.
2. Release clutch lever, the machine will stop.
3. Pull the brake lever together then push "LOCK" button.



## Stopping Engine

- To stop the engine in an emergency, release the clutch control lever, then turn the engine switch to the OFF position.
  1. Move the throttle lever to the SLOW position.
  2. Let the engine idle for one or two minutes.
  3. Turn the engine switch to OFF position.
  4. Turn the fuel valve lever to the OFF position.

## Operation (Using Hydraulic System)

- Always make sure your surroundings is safety before dumping.
- Never dump on a slope area. Machine can tip over.
- Please do not dump bucket without load inside.

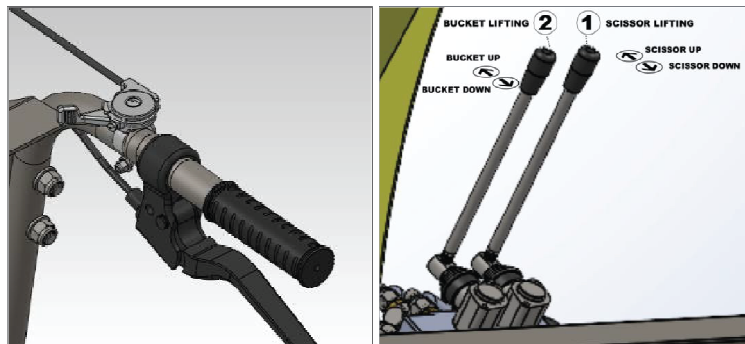

- Raising bucket & scissors lifting
  1. Move throttle lever to [ Fast / High ] position to raise engine speed.
  2. Slowly push scissor handle up to raise the scissor & same as the bucket handle to raise the dumper box.
  3. Till the top, its stops. Then slowly pull down the handle tipping, scissor and dump box lowers back to its original position.

### Notes :

**Move throttle lever to Low position (Low rpm) during bucket move down.**

## Service and Maintenance

### Preventive Maintenance

- Turn off engine and disengage all command levers. Engine must be cool.

- Inspect general condition of the machine. Check for loose screw, misalignment or binding of moving parts, cracked or broken parts that may affect its safe operation.
- Remove all debris and other materials that may have accumulated to the machine. Clean after each use. Then use machine oil to lubricate all moving parts.

## Adjusting Clutch

- As clutch wears out, the same lever could have a wider opening, being so uneasy to use. This means its necessary to adjust the cable, setting clutch lever on its original position.

## Lubrication

- Check oil level every 50 hours of working. Remove the plus & check, with machine horizontal. If necessary, add the oil.

- Oil must

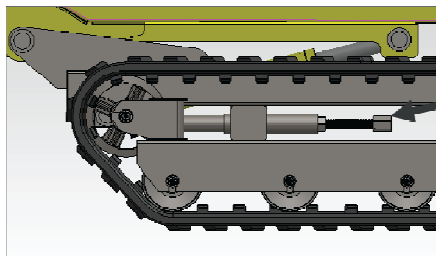

Tension  
Tight  
Rod



be

replaced when hot by unscrewing filler cap and plug equipped with an oil dipstick. When oil is completely drained, replace filler cap and fill up with new oil.

## Engine Maintenance

- Refer to the Engine Manual included in your unit for the information on engine maintenance. Your engine manual provides detailed information and a maintenance schedule for performing the tasks.

## Tightening Tracks

- With use, tracks tends to loose. Operating with loose tracks will damaging the housing.
- To check track tightness, proceed as follows :
  1. Set the machine on a flat surface with compact ground. Better on asphalt or stone pavement.
  2. Lift the machine and set it on blocks or supports rated for the weight of the machine so that the tracks are approximately 100mm off the ground.



3. Measure the track midline vs the horizontal line, the reading must not be more than 10 - 15 mm.
4. If the distance is greater, tighten tension tight rod until the correct tightness is restored.

### Maintenance: Engine Service

Item	Checks/Work	Each Use	20 hrs (1st month)	50 hrs (2nd month)	100 hrs (6th month)	300 hrs (Yearly)
Engine Oil	Check Level	X				
	Change		X		X	
Air Filter	Check	X				
	Clean			X		
	Replace					X
Sediment Cup	Clean				X	
Spark Plug	Check/Clean				X	
	Replace					X
Idle Speed	Check/Adjust					X
Valve Clearance	Check/Adjust					X
Fuel Tank Strainer	Check/Clean					X
Combustion Chamber	Inspect/Clean					X
Fuel Lines	Check					X

### Maintenance: Machine Service

Item	Checks/Work	Each Use	Weekly	20 hrs (1st month)	50 hrs (2nd month)	100 hrs (6th month)	300 hrs (Yearly)
Hydraulic Oil	Check Level	X					
	Change				X		X
Hydraulic Filter	Change				X		X
Transmission Oil	Check Level				X		
	Change				X		X
Fasteners Tension Check	Check	X					
Track Tension	Check/Adjust	X					
Clean Machine	Check	X					
Clutch Adjustment	Check/Adjust		X				
Drive Belt	Check/Adjust		X				
	Replace						X
Grease Points	Grease		X				
All other moving Parts & Cable	Lubricate					X	
Rubber Track	Inspect	X					
Clutch & Steering Handles	Check Function	X					

## Fluids & Lubricants Lists

ITEM	GRADE	CAP
Fuel	Petrol	5.3 L
Engine Oil	10W - 40	1.1 L
Gearbox Oil	EP 90 / GL-5	1.4 L
Hydraulic Fluid	Hydraulic Grade 68	8 L

## After Use Care

- Do not wash engine, control panel, electrical parts or tank caps with air breather with running water, water may enter inside and cause rust or damage.
- Clean the machine after use, leaving dirt or foreign objects may cause component damage and affect its performance.

## Warranty

Your new Mini Dumper is warranted to the original purchase for a period of one year (12 months) from the original of purchase. The Dealer warranty is against defects in design, materials and workmanship.

### **The following are not covered under the Dealer warranty :**

- Damage caused by abuse, misuse, dropping or other similar damage caused by or as a result of failure to follow assembly, operation or the maintenance instructions.
- Alterations, additions or repairs carried out by persons other than Dealer or their recognized agents.
- Transportation or shipment costs to and from Dealer or their recognized agents, for repair or assessment against a warranty claim, on any machine.
- Materials and/or labour cost to renew, repair or replace components due to fair wear and tear.

### **The following wear and tear components are not covered by warranty :**

- Drivebelt(s)
- Rubber track
- Roller, idler, sprocket
- Engine air filter
- Engine spark plug



**The following engine components are covered by warranty :**

Engine warranty covered by engine manufacturer.

**The following manufacturer parts are covered by warranty 100% :**

- Engine base - Welding crack / deformation
- Engine frame - Welding crack / deformation

Dealer and/or their recognized agents, directors employees or insurers will not be held liable for consequential or other damages, loses or expenses in connection with or by reason of or the inability to use the machine for any purpose.





**Uni-corp Europe S.A.R.L.**  
**Paclite Equipment**

12 AVENUE DES COQUELICOTS  
ZAC DES PETITS CARREAUX  
94380 BONNEUIL SUR MARNE  
FRANCE

 +33 (0) 1 49 81 69 55

 +33 (0) 1 48 98 40 88

 [sales@paclite-equip.com](mailto:sales@paclite-equip.com)

 [paclite-equip.com](http://paclite-equip.com)



**2023**