

# THU90H-01 EXCITER HOUSING ASSY

NO	PART NO	PART DESCRIPTION	QTY	UNIT PRICE (EUR) 2023
01-1	THU90H-FN.B-M8x25-8.8-DIN-1	BOLT	12	0,35 €
01-2	THU90H-HSPG.W8-DIN-1	SPRING WASHER, TANG ENDS	12	0,30 €
01-3	THU90H-90B-010100	CLOSE COVER	1	35,05 €
01-4	THU90H-W04-90x3.5	O RING	2	6,35 €
01-5	THU90H-CS.RG40	EXTERNAL CIRCLIP	2	0,90 €
01-6	THU90H-W01-6308-J	BEARING	2	104,36 €
01-7	THU90H-HHOS.B-M12x1.5	HEXAGON HEAD PLUG	1	2,30 €
01-8	THU90H-GB97.1-M12	CUPRUM WASHER	1	0,75 €
01-9	THU90H-90B-010300	EXCITER HOUSING	1	287,01 €
01-10	THU90H-90B-010200	EXCITER SHAFT	1	183,27 €
01-11	THU90H-90B-010500	COVER	1	43,35 €
01-12	THU90H-90B-010700	WASHER	1	
01-13	THU90H-W03-75x40x12	OIL SEAL	1	8,95 €
01-14	THU90H-90B-010400	PULLEY	1	58,80 €
01-15	THU90H-90B-010600	WASHER	1	58,55 €
01-16	THU90H-HSPG.W10-DIN-1	SPRING WASHER	1	0,30 €
01-17	THU90H-90B-010800	VENT SCREW	1	3,05 €

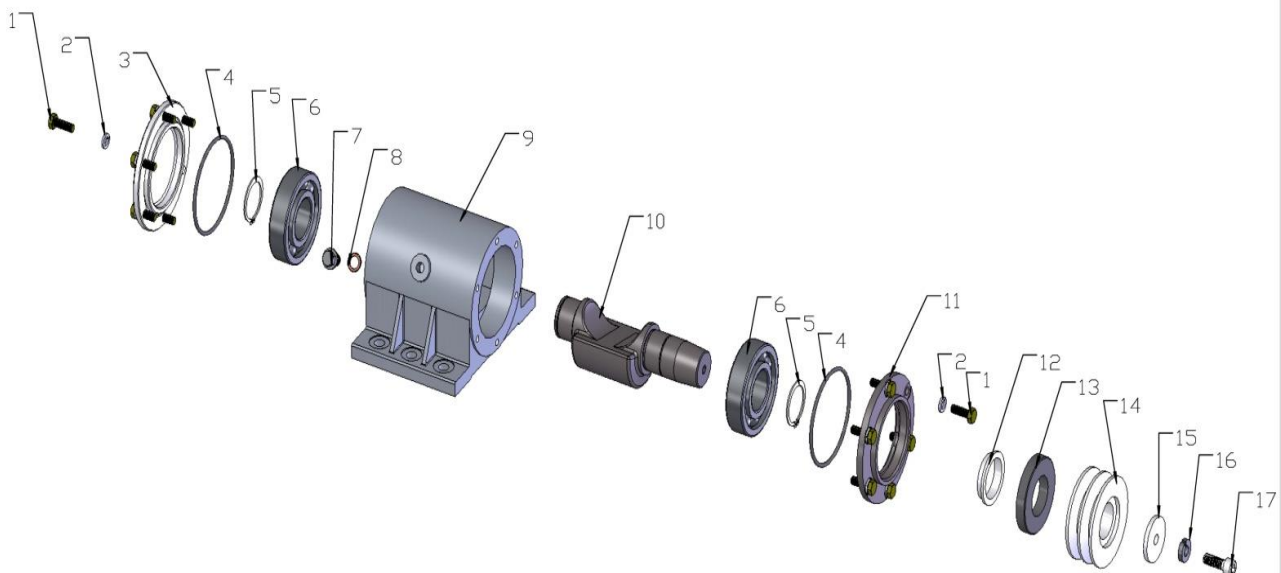

Drawn	WLJ	Model	THU95H	Drawing No.	THU95H-01
Checked		Description	EXCITER HOUSING ASSY		
Approved		Date	2016/12/19		

## THU90H-02 MAIN FRAME ASSY

NO	PART NO.	PART DESCRIPTION	QTY	UNIT PRICE (EUR) 2023
02-1	THU90H-90B-020100	BASE PLATE	1	254,49 €
02-2	THU90H-90B-030100	SHOCK ABSORBER	4	49,45 €
02-3	THU90H-FN.W12-DIN-1	WASHER	10	1,35 €
02-4	THU90H-IN.N-M12-DIN-1	LOCK NUT	8	0,55 €
02-5	THU90H-90B-040100	ENGINE BASE	1	205,49 €
02-6	THU90H-HSPG.W12-DIN-1	SPRING WASHER	6	0,35 €
02-7	THU90H-FN.B-M12x45-12.9-DIN-1	BOLT	6	0,70 €
02-8	THU90H-90B-030300	COVER	1	11,50 €
02-9	THU90H-FN.B-M10x70-8.8-DIN-1	BOLT	1	1,30 €
02-10	THU90H-FN.N-M10-DIN-1	NUT	1	0,40 €
02-11	THU90H-W05-GX160H1-SX	ENGINE	1	
02-12	THU90H-60-060200	BOLT	2	11,00 €
02-13	THU90H-FN.W8-DIN-1	WASHER	4	0,30 €
02-14	THU90H-HSPG.W8-DIN-1	SPRING WASHER	5	0,30 €
02-15	THU90H-IN.N-M8-DIN-1	LOCK NUT	4	0,40 €
02-16	THU90H-WOD.W8-GB-1	WASHER	4	0,35 €
02-17	THU90H-80-0317	WASHER	1	4,05 €
02-18	THU90H-Key.B-5x5x32	KEY	1	9,40 €
02-19	THU90H-80-0500A	CENTRIFUGAL CLUTCH	1	148,04 €
02-20	THU90H-80-0318	CLUTCH PULLEY	1	125,80 €
02-21	THU90H-W01-6006ZZ-G	BEARING	1	18,15 €
02-22	THU90H-CH.RG55	INTERNAL CIRCLIP	1	3,45 €
02-23	THU90H-CS.RG30	EXTERNAL CIRCLIP	1	0,45 €
02-24	THU90H-W02-A29	V-BELT	2	30,05 €
02-25	THU90H-80-0319	WASHER	1	6,30 €
02-26	THU90H-FN.B-M8x30-8.8-DIN-1	BOLT	1	0,45 €
02-27	THU90H-90B-030200	BELT COVER	1	67,60 €
02-28	THU90H-80-0408	CUSHION	2	15,80 €
02-29	THU90H-FN.B-M8x20-8.8-DIN-1	BOLT	4	0,35 €
02-30	THU90H-IN.N-M10-DIN-1	LOCK NUT	2	0,40 €
02-31	THU90H-90B-050100	OPERATION HANDLE	1	150,12 €
02-32	THU90H-60-050400	NYLON BUSH	4	11,80 €
02-33	THU90H-FN.W16-DIN-1	WASHER	4	0,75 €
02-34	THU90H-FN.B-M16x80-8.8-DIN-1	BOLT	2	1,75 €
02-35	THU90H-IN.N-M16-DIN-1	LOCK NUT	2	0,60 €
02-36	THU90H-FN.B-M6x20-8.8-DIN-2	BOLT	2	0,35 €
02-37	THU90H-HSPG.W6-DIN-2	SPRING WASHER	2	0,35 €
02-38	THU90H-HC.N-M6-DIN-2	CAP NUT	2	0,40 €
02-39	THU90H-HC.N-M10-DIN-2	CAP NUT	1	1,30 €
02-40	THU90H-FNL.N-M10-DIN-2	HEXAGON THIN NUT	1	0,40 €
02-41	THU90H-FN.W10-DIN-2	WASHER	2	0,30 €
02-42	THU90H-70ND-060000	THROTTLE LEVER	1	29,05 €
02-43	THU90H-FHSS.S-M6x8-GB-3	SOCKET SCREW WITH FLAT HEAD	1	0,35 €
02-44	THU90H-HC.N-M8-DIN-2	CAP NUT	1	0,45 €
02-45	THU90H-FNL.N-M8-DIN-2	HEXAGON THIN NUT	2	0,30 €
02-46	THU90H-FHSS.S-M8x20-GB-3	SOCKET SCREW WITH FLAT HEAD	1	3,30 €
02-47	THU90H-70ND-060001	THROTTLE BODY	1	38,95 €
02-48	THU90H-70ND-060003	BOLT	1	16,25 €

02-49	THU90H-70ND-060002	THROTTLE GEAR	1	32,45 €
02-50	THU90H-W04-45x3	O-RING	1	6,00 €
02-51	THU90H-70ND-060004	SLIDER	1	9,70 €
02-52	THU90H-W06-S04-L800x1000	THROTTLE CABLE	1	64,50 €
02-53	THU90H-70ND-010018	THROTTLE LEVER ASSY		108,48 €

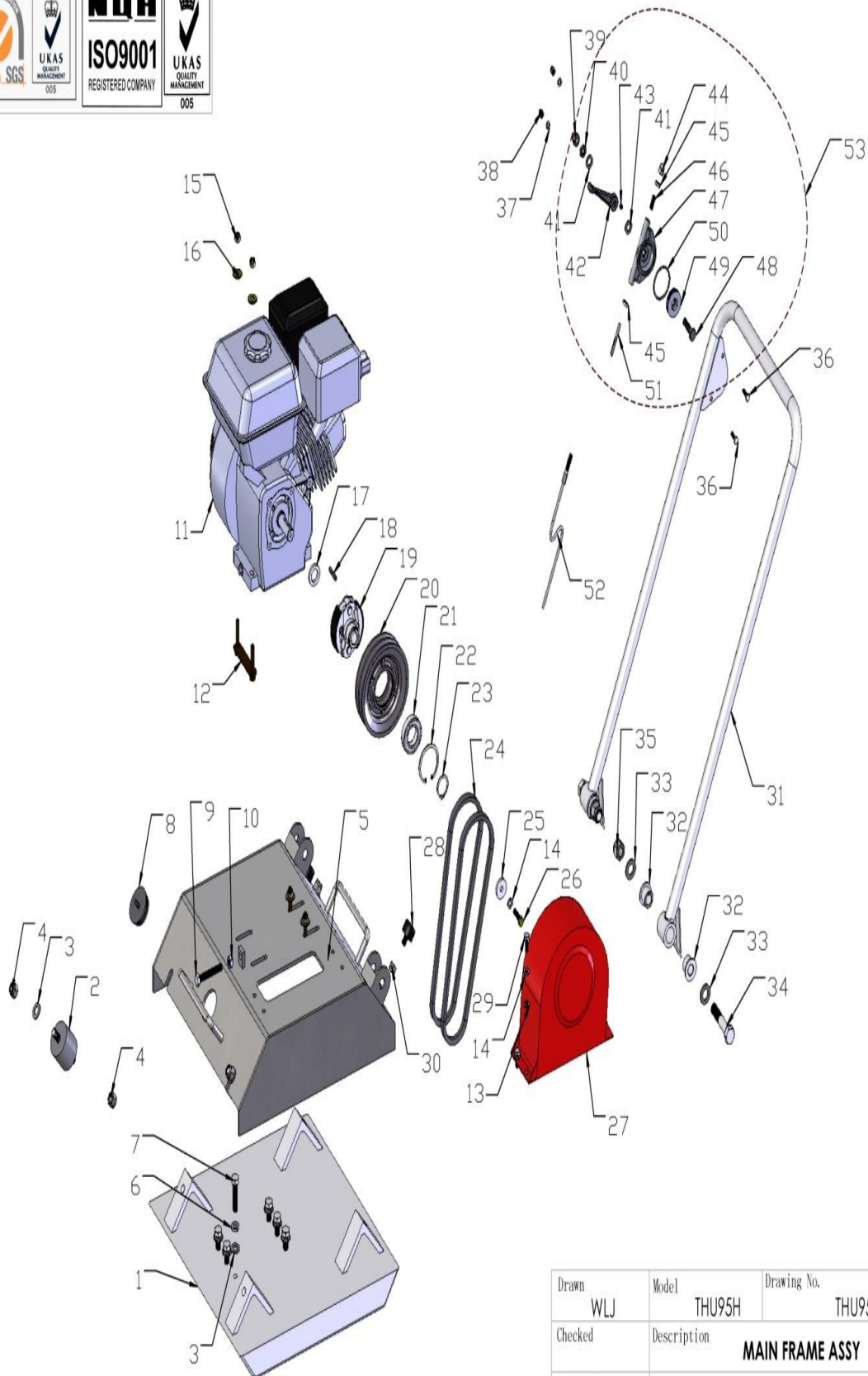

Drawn	Model	Drawing No.
WLJ	THU95H	THU95H-02
Checked	Description	
	<b>MAIN FRAME ASSY</b>	
Approved	Date	
	2016/12/19	