

SPM-Surface Grinder

PACLITE scarifiers and tools have been well known for years but sold by our customers under other brands.

The design combines strong fabrication with heavy-duty performance.

This technique is meant for a deeper removal of material. It is ideal for the complete floor renovations of production halls, factories, farm buildings, parking lots and many other large utility buildings on both upper floor and underground levels.

FEATURES AND BENEFITS

- Etching, cleaning, paint removal on any surface.
- Can be used to remove glues, rubber and more difficult coatings.
- Ideal for road marking removal.
- Levelling of uneven concrete floors.
- Compact and easy to manoeuvre.
- Deep and precise milling of concrete, resin, asphalt.

POWERED by
HONDA
Norm SAE J1349



Code	SPM1
Model	SPMH
Dimensions L x W x H (mm)	900 x 410 x 1110
Working width (mm)	203
Weight (kg)	66
Working depth (mm)	3
Working capacity (m ² /h)	30-46
Engine	Honda GX160
Net Power hp (kW)	4,8 (3,6)
Max. speed engine (rpm)	3600
Fuel tank capacity (L)	3,1
Engine oil capacity(L)	0,6
Fuel consumption at rated power (L/h - rpm)	1,4 - 3600
Certified power SAE J 1349	

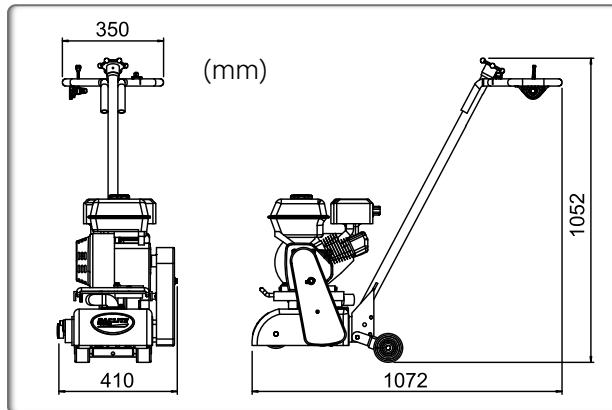

Code	Model
SPM1-070400-6	Point TC cutter (total 76 needed 8 mm high Tungsten) full set
SPM -FN W12 TC	Cutter shims (total 88 pieces needed)

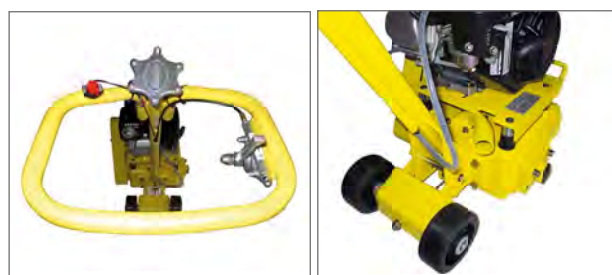

Operating handle

Outlet for dust collector