

Terrain Loader

PACLITE specializes in solutions to service sites, since we always pay attention to the specific requirements of our customers by offering the expertise of our technicians and reliability of the brand PACLITE which boasts experience in its field. Perfect for any type of work and made from high quality components. Useful for eliminating operator fatigue.

Manoeuvrable in tight spaces, quick and agile in movement, strong, robust and compact, but also available and adaptable to your requirements according to the multitude of sectors in which they can be used.

It is also possible to load and transport these loaders on most trucks due to their small size and light weight.



Code	HTL350
Model	HTL350
Dimensions L x W x H (mm)	1802 x 721 x 955
Engine	Honda GXV160
Start	Manual
Engine power hp (kW)	5,5 (4)
Max speed (km/h)	5,8
Capacity (l)	137
Capacity (kg)	345
Weight (kg)	162
Vibrations (m/s ²)	4,52
Engine speed (rpm)	2890
Larson Davis HVM test equipment 100 - Tri-axial accelerometer	

POWERED by
HONDA
norm SAE J1349

FEATURES AND BENEFITS

- Robust design of the hopper and discharge system, better balanced and more weight compared with other machines on the market.
- The Terrain Loader has a Honda engine of 5,5 Hp.
- It allows larger capacity 345 kg.
- Motorized 4-wheel loader drive that can go anywhere a tracked machine can.
- Perfectly balanced, the operating gear is smooth and easy as driving to empty at full load.
- Easy and fast for high productivity.
- All four tires are identical for easy use on all types of terrain.
- The bucket is changed within seconds with the flat tray; both are always included in the delivery of the machine.
- May climb hills up to 30 degrees.
- USA manufactured gear box Tecumseh.
- It combines well with a number of other types of equipment such as mini-excavators and cement mixers.
- Clutch EC.

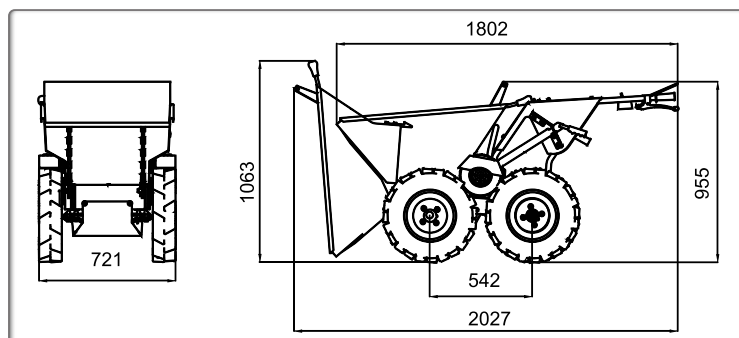

Flat tray always included