

Multiple use rammer

TR740 - A rammer with a rugged design for multiple uses. This rammer is suitable for applications on both granular and cohesive soils, where strict requirements are imposed for compaction in confined areas, trenches and repair work.

TR800D - This standard PACLITE **diesel rammer** offers maximum production, performance and durability while providing you the convenience of standardizing your diesel fleet. A well-balanced machine for easy handling and operation.

The TR800D is the heavyweight amongst the rammers and is exceptionally reliable because of its engine. Its preferred use is on soils which are difficult to compact, on sites where solely diesel fuel is used to avoid the accidental mix up of fuels and also on various repair jobs.

FEATURES AND BENEFITS

TR740

- Strong protective frame and engine support.
- Transports in any position.
- A unique three-stage air filtration system provides a virtually dust-free engine for longer life and improved durability.

TR800D

- A durable HATZ 1B20 diesel engine provides exceptional performance, fuel economy and long life.
- The large capacity fuel tank with self-cleaning in-tank filter, offers long life and minimum maintenance.
- Exclusive noise reducing cover lowers the amount of engine and shoe noise transmitted to the operator.
- New clutch system from German Amsbeck.

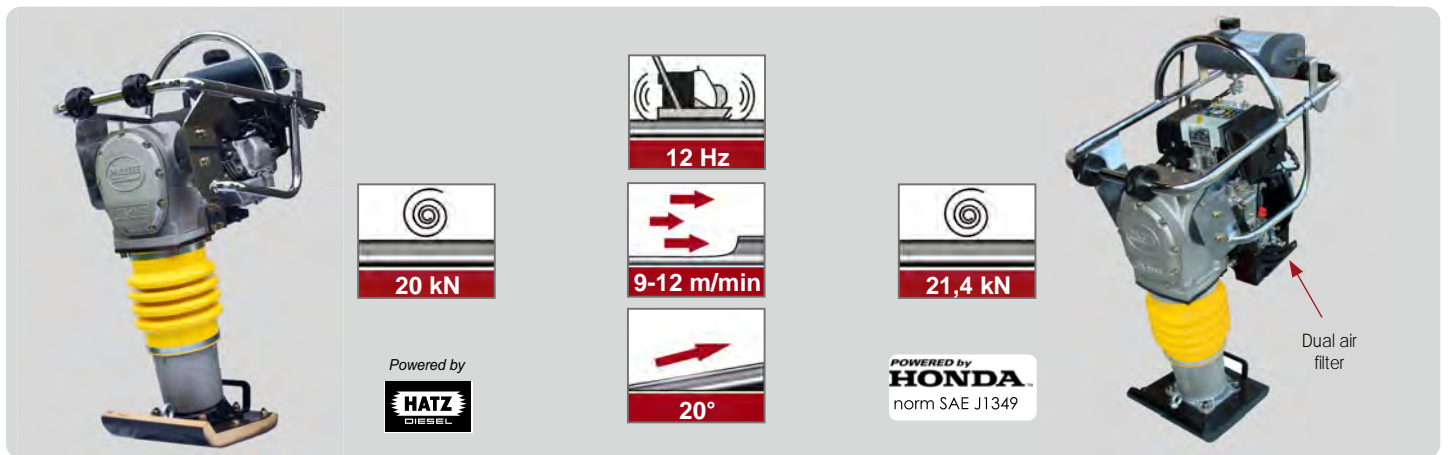

TR740

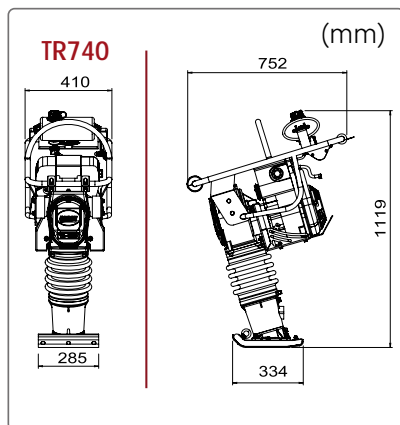

Wood laminated foot

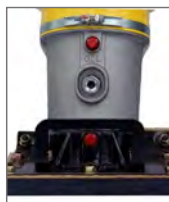

Oil level gauge



TR800D

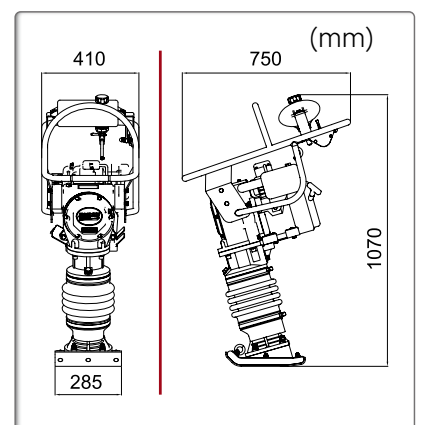

Code	TR740H	TR800D
Model	TR740	TR800D
Operating weight (kg)	70	84
Centrifugal force (kN)	20	21,4
Plate size (mm)	335-285	334 x 285
Engine	Honda GX120	Hatz 1B20 -V5
Power hp (kW)	3,2 (2,4)	4,6 (3,5)
Speed (m/min)	9 - 12	9 - 12
Amplitude (mm)	65 - 75	75 - 85
Frequency (Hz)	12	12
Sound level dB (A)	104	92
Percussion rate max. (Blows/min)	690	690
Surface capacity compaction (m ² /h)	123	123
Operating speed (m/min)	7,5	7,5
Vibrations* (m/s ²)	4,9	9,6

* Minimum vibration levels measured to EN500-4

TR740 / TR800D

Wheel kit OPTION	
Code	OP/TR-WHEEL

