



CRX698 RAMMER & NEW CRX698 ECOPOWER RAMMER*

Fully anti-vibration operator handle



Work in absolute comfort, low hand-arm vibration, unique in the industry.

The CRX698 is the first low-vibration hand-arm rammer in the market. It has exceptional characteristics such as flexibility, high and powerful percussion for perfect stability at work.

Honda GXR120 engines (air-cooled, drive shaft horizontal power take-off, cast iron jacketed cylinder with carburettor diaphragm) enable very high performance.

A unique air filtration system, at three levels: first, a cyclonic filter which absorbs the raw materials, then an air filter and then the filter in the Honda engine. Its design keeps the engine practically dust-free and gives it a remarkable lifespan.

The sole of the foot is handcrafted from laminated wood and steel, providing flexibility and endurance. The rammer CX698 has a replaceable (patent-pending) one-piece piston with molded Teflon trim that doubles its life.

FEATURES AND BENEFITS

- Remarkable flexibility and working comfort.
- Cyclone air pre-filter for five times less maintenance intervals.
- Automatic oil level control.
- Easy access points for engine maintenance.
- Anti-vibration handle, the lowest vibration rate in the labor force industry.
- Engine speed indicator and hour meter.
- Protective cover fitted with a tachometer.
- Central sling ring.
- Wheels mounted on the drawbar for loading.
- Engine stop integrated on the handle.
- 380 mm narrow frame.
- Bellow and foot of German fabrication.
- Honda GXR120 engines.
- Available with battery motor EGX honda.

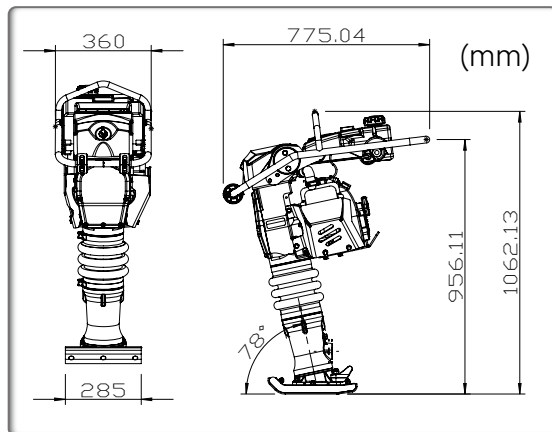

Interchangeable rammer shoe

Code	CRX698-HAV	CRX698-ECO
Model	CRX698-4 HONDA	CRX698 ECOPOWER
Operating weight (kg)	68	71
Plate width (mm)	335-285	335-285
Engine	Honda GXR120	Honda EGX
Power hp (kW)	3,1 (2,3)	2,4 (1,8)
Engine speed (rpm)	3600	3600
Cylinder (cm³)	121	-
Consumption of fuel (l/h)	1,1	-
Speed (m/min)	8 - 15	8 - 15
Amplitude (mm)	70 - 85	70 - 85
Frequency (Hz)	12	12
Centrifugal force (kN)	18	18
Sound pressure level dB (A)	104	45
Percussion rate max. (blows/min)	640	640
Operating speed (m/min)	8,9	8,9
Surface capacity compaction (m²/h)	149	149
Vibration emission value* (m/s²)	3,2	-
CO2 (NRSC) (g/kWh)	655	-
Hand-arm vibration* (m/s²)	3,1	6,2
* Minimum vibration levels measured to EN500-4		
Certified power SAE J 1349		

OPTIONS		
Code	CR/SHOE-170	CR/CR-WHEEL
Model	Interchangeable rammer shoe 170 x 135 mm	Transport wheel kit



Wheel kit OPTION



Tachymeter



Cyclone filter

COMPACT ION

MOBILE EQUIPMENT

CONCRETE EQUIPMENT

SURFACING

CUTTING - GRINDING

Vibrating plate and rammer with Honda battery

PACLITE's battery-powered vibratory plates and rammers operate emission free and therefore suitable for many sensitive compaction or trenching applications. These machines are equipped with battery-powered Honda engines that provides a full day of compaction work time. Their performance is equal to those of conventional engines. The vibrating plates are always equipped with a watering kit and transport wheels.

FEATURES AND BENEFITS

- Great surfacing capacity.
- Electric motor, with proven timing belt, for zero maintenance and very low service costs.
- The emission-free engine protects the operator on all construction sites and opens up new fields of application indoors and in areas where emissions are regulated (city centres).
- Low energy cost for a **saving of approximately 75% for the V400 and 65% for the CRX698** compared to petrol machines in the same weight range.
- **100% zero emission work.**
- Reliable starting in any weather and at any altitude: Just press a button.
- The battery can be used with other PACLITE vibratory plates.

POWERED by HONDA

eGX



Code (CE)	GXE2.0H	Code (CE)	DP72104Z	Code (CE)	CV7285Z
Model	V400 / CX698 Motor E-GX ECO battery	Model	Battery	Model	Rapid charger
Type	DC, brushless, three-phase, forced air-cooled permanent magnet	Type	Lithium battery ion rechargeable	Type	Constant voltage and current fast charger, forced air cooling
Net power kW (HP) rpm	1,8 (2,4) 3600	Voltage (V)	72 continuous	Voltage (V)	100 to 240 alternative
Control	PWM 3 phases	Available energy (Wh)	720	Frequency (Hz)	50/60
Regulated current (A/V)	27 / 72	Nominal capacity (Ah)	10	Tension (V)	82,8 continuous
Compatible battery	DP72104Z	Dimensions L x W x H (mm)	233 x 268 x 150	Output current (A)	8,5
Compatible charger	CV7285Z	Weight (kg)	6,4	Dimensions L x W x H (mm)	272 x 352 x 270
Dimensions with battery L x W x H (mm)	294 x 353 x 420			Weight (kg)	11,2
Weight with battery (kg)	26,1				