

High capacity asphalt plate compactor

Segregation in materials can be a big problem. There are a number of emerging technologies in asphalt compaction that allow for the manipulation of binder viscosity and thus lower mixing and paving temperatures through chemical modification. This creates a demand for specially designed machines for use on the various types of asphalt layers.

PACLITE compactors minimize segregation problems and promote homogeneity of material and air void distributions within the compacted layers.



POWERED by
HONDA
norm SAE J1349



FEATURES AND BENEFITS

- High strength aluminium components including the engine console and belt guard have been combined for reduced weight and easy machine handling.
- Straight, centre-mounted guide handle offers superior manoeuvrability and can be lowered within inches of the surface to operate plate under obstacles and form work.
- High rate of travel due to well designed base plate geometry and good weight distribution.
- Design for outstanding handling especially in confined conditions.
- Large removable water filter located inside of water tank prevents clogging during operation and can be easily removed by sliding off the attachment for filling and draining.
- Angled holes on spray bar allow complete water coverage for no asphalt pick-up on plate bottom.
- Special Delta shaped bottom plate for compaction and moving of thin asphalt layers.

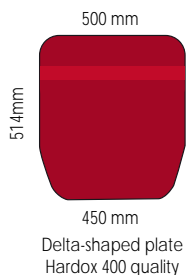
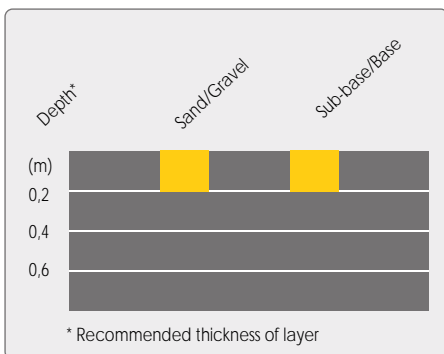
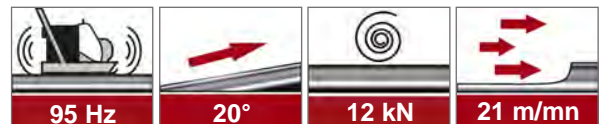
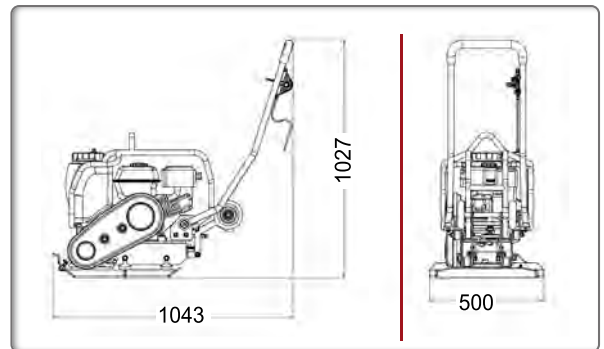

System to reduce HAV
(Hand-arm Vibration)

Code	PX5.0A
Model	VECTOR PX5.0
Operating mass (kg)	77
Centrifugal force (kN)	12
Plate width (mm)	500
Engine brand	Honda GX160
Net power hp (kW)	4,8 (3,6)
Rated engine speed (rpm)	3600
Fuel tank capacity (L)	3,1
Engine oil capacity (L)	0,6
Fuel consumption at rated power (L/h - rpm)	1,4 - 3600
Water tank (L)	13
Speed (m/min)	21
Amplitude (mm)	0,9
Frequency (Hz)	95
Sound pressure level dB (A)	91
Vibrations* (m/s ²)	3,5
* Minimum vibration levels measured to EN500-4	
Certified power SAE J 1349	