

Fully hydrostatic, dual vibration system

The innovative DR8000 walk behind roller helps you limit your machine investment. A double stage high-amplitude setting provides this walk-behind roller the ability to perform on both soil and aggregate surfaces. With the flip of a switch your operator can adjust to a low-amplitude setting and have a roller that is a perfect fit in asphalt and bituminous materials. This roller is equipped with the powerful Hatz 1B50 engine with electric start and easy accessible control panel on steering handle. The drive and vibration are fully hydraulic, eliminating V-belt and clutch. DR8000 features scrapers and a 50-litre water tank with sprinkler system to ensure the machine is ready to handle bituminous surfaces when called upon. This unique PACLITE roller offers perfect clearance on both drum sides, allowing compaction work extremely close to curbstones, retaining walls and other obstacles. No extra time-consuming work on edges and in confined areas is needed. The hydraulic drive ensures variable speed adjustment and smooth starting/braking action.

FEATURES AND BENEFITS

- Two large Poclair hydraulic drive pumps and a vibration pump from Sauer Danfoss
- Air-cooled HATZ diesel engine: powerful and environmentally friendly.
- Hydrostatic drive and vibration system.
- Hydrostatic adjustable excentric weights that are productive in both soil and asphalt applications.
- Hydraulic pump for hydrostatic drive and steering: no V-belt or clutch.
- Ergonomic vibration dampened operator handle, control panel with easy access.
- Hydrostatic control lever and adjusting lever.
- Two removable drum scrapers ensuring automatic cleaning.
- MAXIMUM SAFETY: dead man safety button.
- Hydraulic parking brake, reverse gear limited to 2,5 km/h.
- Adjustable amplitude on asphalt (13 kN) as well as on soil (21 kN).
- Anti-corrosive oil tank.



Powered by

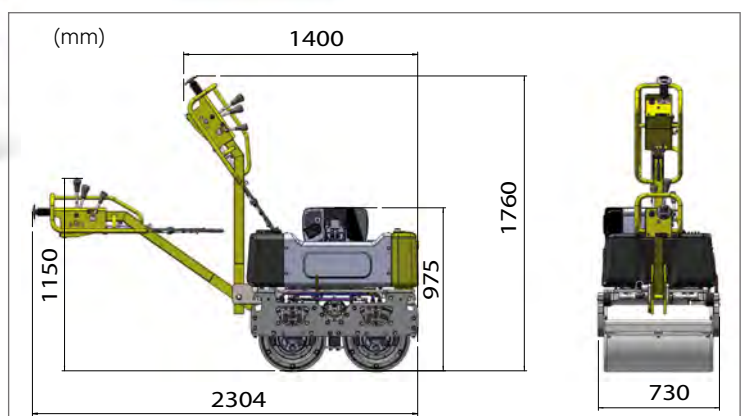



Powered by



+ WEIGHT
+ COMPACTION
+ POWER
+ COMPACT



Code	DR8000H
Model	DR8000
Weight CECE (kg)	770
Working width (mm)	650
Linear charge (kg/cm)	5/28
Drive	Hydrostatic
Diesel engine	Hatz 1B50-V5
Engine power hp (kW)	11,3 (8,5)
Forward speed (km/h)	4
Speed reverse gear (km/h)	2,5
Vibration	Hydrostatic
Centrifugal force to choose (kN)	13/21
Vibration motor brand	Sauer Danfoss
Vibration frequency Hz (vpm)	70 (3300)
Gradeability with/without vibration (%)	25/45
Water tank capacity (L)	50
Hydraulic oil tank (L)	20
Fuel consumption (L/h)	1,2
Hour meter	Option
Protective cover	Yes
Compaction Depth* big or small amplitude	
*According to the nature of the soil	
Sand/gravel (cm)	30/25
Usual soil (cm)	20/15
Sound level dB (A)	95
Hand-arm vibration (m/s ²)	4

COMPACTION

MOBILE EQUIPMENT

CONCRETE EQUIPMENT



All PACLITE models are ergonomically designed and comfortable.



Reinforced thick frame

Operating handle with integrated electronic controls



Excellent performance of compaction of all our models.



Control panel with double amplitude



Switch between two amplitudes

Low amplitude for use on asphalt surfaces. Large amplitude ensures efficient and rapid compaction of sub-base or soil.

SURFACING



Two hydraulic Poclair pumps



Sauer Danfoss Vibration motor

CUTTING - GRINDING