



Site Construction machines, Compaction
Concrete work, Lighting, Cutting, Pumping, Surfacing

**A complete equipment range for
construction professionals**

 + 33 1 49 56 02 82

PACLITE-EQUIP.COM





Technical and Logistics Centre France Parts and Maintenance Service - Assembly Plant

Technicians at your service for all your PACLITE Equipment machinery.



PACLITE SERVICES presents its French production site of Villeneuve St Germain 02200 (Soissons), including our assembly lines and the technical and logistical center on 3000 m² of dedicated space!

More than 26,000 parts STOCKED!

- Assembly,
- Repair shop,
- Testing and engineering zone.

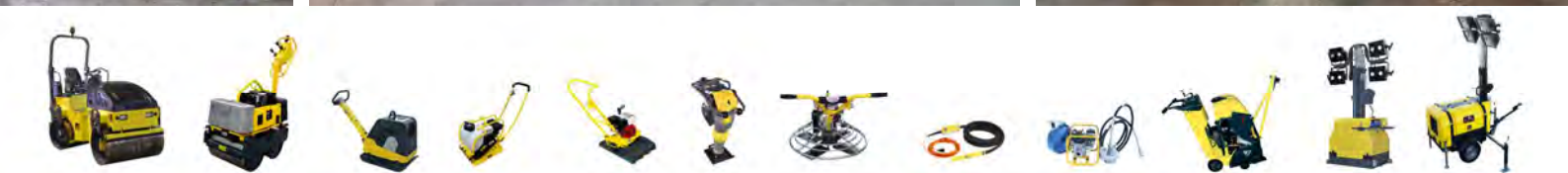
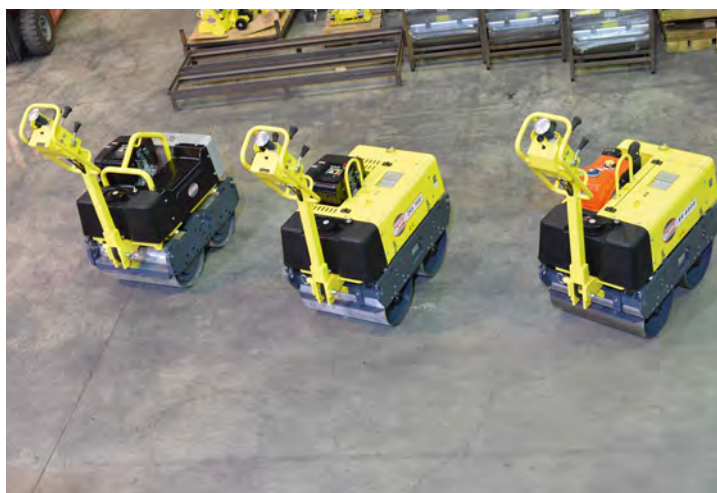

CORPORATE PROFILE	4
COMPACTION	5
Tandem Roller - ROADMASTER 900	6
Tandem Roller - ROADMASTER 1200	8
Duplex Roller DR8000	10
Duplex Rollers for soil and asphalt VR6500 KF3 / DRX7800 HATZ	12
Round plate compactor - PX91	13
Reversible Plates IMPACT 200/230	14
Reversible Plates IMPACT SERIES 444	15
High capacity asphalt plate compactor - VECTOR PX5.0	16
Compactor for stone and pavers - ROLL PAV 120	17
Reversible Plate PC100	18
Versatile forward plate compactor - V400 & V400 ECOPOWER	19
Premium Asphalt Plate - PC60	20
Extra Light-weight forward compactor - LCC40W	21
Vibrating plate & rammer with battery V400 ECOPOWER & CX698 ECOPOWER	22
Rammers CRX698 & CRX698 E-POWER	23
Rammers - TR740 & TR800D Diesel	24
SITE CONSTRUCTION MACHINES	25
Tower Light - PAC-LIGHT PL2000 ECO LED V6	26
Tower Light - PAC-LIGHT PL4000	28
Tower Light- MAXI LIGHT PLUG-IN LED and PLUG-IN & GO HYBRID	30
Soil Pick PAC-PIO3.0 & Pole scabblers POL-PAC	31
Pneumatic breakers - PAC-TEC	32
Centrifugal Pump - WP80	34
PFP80 - Submersible flexible shaft pump 72 m ³ /h	35
Terrain Loader - HTL350	36
500 kg Track driven Power dumper MD500	37
PACLITE generators PAC-GEN	38
CONCRETE EQUIPMENT	39
Battery powered concrete vibrator - E-VIB	40
Eco-friendly high frequency concrete vibrator -ECO-VIB	41
Hand held portable poker vibrator - PORTAVIB	42
High Frequency hand-held poker vibrator - MULTIVIB & MULTIVIB COMPACT	43
Converters - FUZ, BOXTECH - NEW	44
High Frequency concrete vibrator - VX PREMIUM-VX BOOSTER	45
High Frequency pokers with built-in inverter - SYNCHROMASTER & ERGOTRONIC	46
Flexible shaft pokers - FP27- FP62	47
Pneumatic pokers vibrator - VP25-VP105	48
SURFACING AND FLOOR PREPARATION EQUIPMENT	49
Trowels M600NH Superior, M600 ECO-POWER, M600E-230V electric & M700	50
Trowels M900 & M1200	51
First battery operated trowel -M900-ECO	52
PRT168 - Mechanical ride-on trowel	53
Trowel Accessories	54
Surface Screed - SUPER-SCREED	55
Surface Screed VVL 200/300/-E 230V electric & concrete hand tools	56
CUTTING & GRINDING	57
Surface grinder- SPM	57
Electric surface grinder - CUB GRINDER	58
Electric surface grinder - PAC-GRIND	59
Walk-behind floor saws - PRECISION CUT 4-5, 500D & 500P	60
Walk-behind floor saws CUT SPEED 450	61
Diamond blades	62
CUSTOMER SUPPORT	63

COMPACTION

MOBILE EQUIPMENT

CONCRETE EQUIPMENT

SURFACING

CUTTING - GRINDING

PACLITE innovates to actively participate in the global climate effort.

The Paris Agreement requires all Parties to put forth their best efforts through determined contributions (NDCs) and to strengthen these efforts in the years ahead. This initiative includes requirements that all Parties regularly report on their emissions and their implementation efforts.

PACLITE Engineering have taken all possible measures to develop machines with the aim to reduce or remove CO₂ in process and work.

In 2019, we introduced a tower light with the lowest emission in the market. Two new revolutionary battery vibrators were also introduced with the goal of improving capacity and autonomy.

PACLITE believes that to secure permanence in today's market, it is essential to offer quality products and services and to have a responsible attitude within society, for example, in taking into account the impact of its commercial activities has on the environment and society.

It is in this spirit that PACLITE engineers worked hard on developing a power source that can combine our machines with battery power for construction applications.

In 2023 PACLITE will introduce a wide range of battery-driven machines to respond to the new technology.



ECOLED

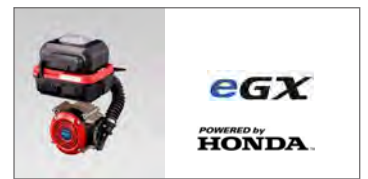

PACLITE Equipment - a brand within the Uni-Corp group

The progress and quality

This applies to all the innovations PACLITE has developed in recent years. We are among the largest number of producers in innovations and product improvements.

Close to its customers - For PACLITE, the customer is in the centre and is of utmost importance. We pay attention to comments in order to provide total satisfaction to our customer base.

Premium Services - PACLITE offers an experienced in-house team and support. That's why we only produce and design within these areas of expertise.

Safety at work

"Hand-Arm Vibration" (HAV syndrome) is a group of diseases caused by the exposure of the Hand-Arm Vibrations. The best known of them is the "white finger disease" disorder of blood circulation in the fingers caused by compression of the nerves of the wrist. The vibration of machinery must be eliminated to the maximum effort.

Mechanized equipment commonly used in powered hand tools or physical agents (Vibration) Directive 2002/44/EC, as well as the new Machinery Directive 2006/42/EC.



New range of battery powered and electric machines: zero CO₂ emissions.



CRX698
ECOPOWER



V400
ECOPOWER



M600BP
ECOPOWER
& M600E-230V



EVIB



ECO-VIB



M900-ECO



VVL-E 230V

TANDEM AND DUPLEX ROLLERS, PLATES, RAMMERS, ROUND PLATE

RM1200



RM900



VR6500 KF3



DRX7800 HATZ



DR8000



CRX698-4



CRX698 ECOPOWER



TR800D



TR740



LCC40



PC60



VECTOR PX5.0



V400 & V450 COMBI
V400-ECOPOWER



PC100 HATZ



PC100 HONDA



IMPACT 200/230



IMPACT 444



ROLL PAV120



PX91



900 mm Dual Drum Roller

Drum width of **900 mm** it's primarily used for small-scale compaction work such as pavement cycle paths, small roads and small parking areas. The large diameter drum and drive motors connected in series contributes to its excellent accessibility and hill-climbing capacity. Propulsion and vibration come as standard on both drums.

Designed for compacting base and finishing layers of asphalt as well as granular sub-base material in confined areas. Ideal for parking lots, driveways and shoulder work.



Quieter than before

High visibility during operation

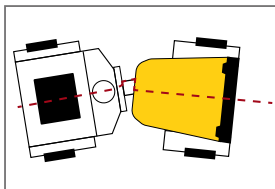

The shape of the roller provides high visibility around the edges of the rollers during operation.

High stability while driving

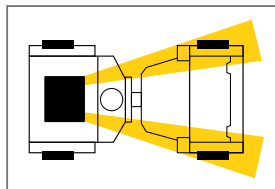

Operator security and comfort with PACLITE designed oscillating pivot steering on uneven surfaces or while turning.

FEATURES AND BENEFITS

- Three position function vibrator switch, dual drum vibration with possibility switch off rear drum and front drum only vibration. Work lights front and rear, variable hydrostatic steering forward and reverse. Pressurized sprinkler system.
- Lights on both sides of the machine.
- Hydrostatic drive with variable speed.
- Self-cleaning drum for good traction and better surface finish with 2 scrapers.
- Large-size water tank for extended use and reduced refill stops, easy cleaning access.
- Self-draining sprinkler tubes and nozzles.
- Long service intervals together with comfort.
- Dual forward/reverse levers for total operator comfort.
- Scrapers on each cylinder, maintained and folding spring.
- Fuel level gauge.
- Emergency stop.
- Back-up alarm.
- Central lifting point.
- Vandal-proof protection.
- Engine cover lock.
- Max. m/min 183.
- Crossing slope with vibrations 32 %.
- Slippery slope without vibration 42 %.



Code	RM900D
Model	ROADMASTER 900
Dimensions L x H (mm)	2095 x 2560
Operating weight (kg)	1620 with ROPS
Weight on cylinder front/rear (kg)	740/835
Drum size (mm)	900
Centrifugal force (kN)	28
Amplitude (mm)	0,60
Static line load front/rear drum (kg/cm)	8,3/9,4
Frequency (Hz)	69
Engine Kubota D1105-E4B T4f	3 cylinders
Cooling	Water
Emission regulation	Tier 5
Engine power - hp (kW)	25 (18,5)
Water tank capacity (l)	110
Brand Hydraulic system	POCLAIN/CASAPPA
Certified power SAE J 1349	



Kubota engine with linear assembly to allow access and maintenance from both sides of the engine.



Roller features support transport rail



Lockable hood

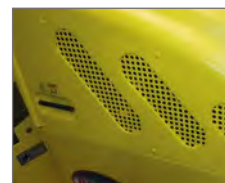

Fiberglass hood



Ergonomic steering wheel

Operator comfort



Ergonomic seat

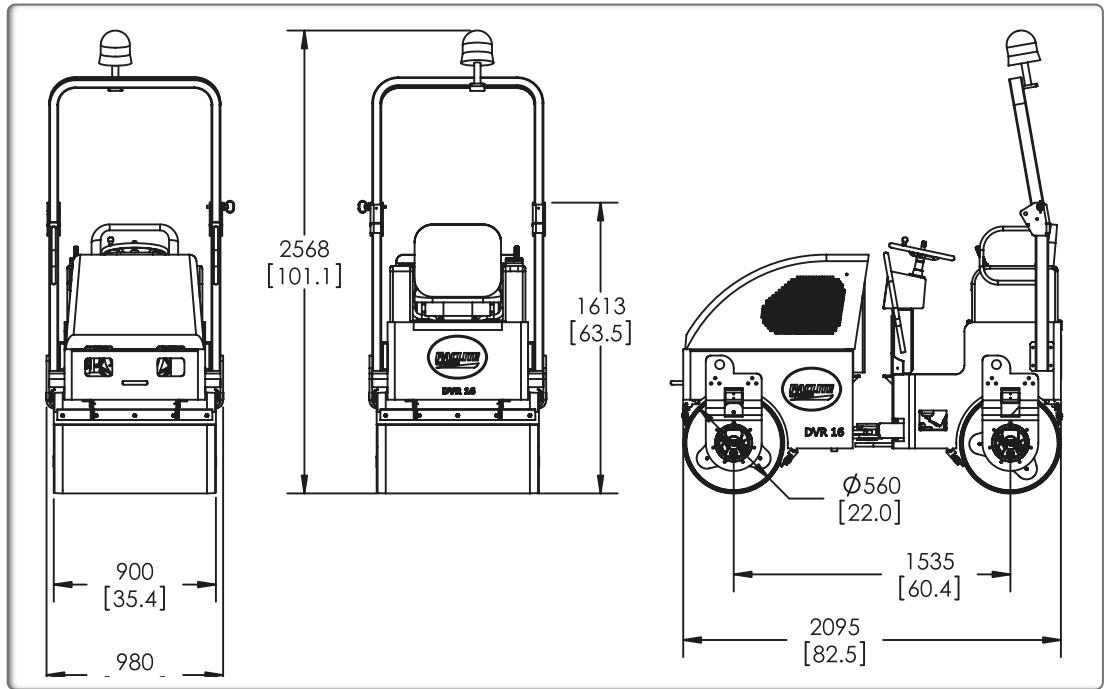

Lubrication point on each cylinder and Poclair drive motors

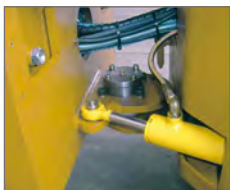

Unique pivot articulation with grease point



Diesel fuel cap easy access on operator floor

The specially designed vibrating cylinder oscillates the material to be compacted optimally by vertical forces in rapid succession. Integrated unbalance eccentric provides high frequency and exceptional compaction quality.

PROPULSION	
System Type CASAPPA (Italy)	Closed-loop, hydrostatic, parallel circuit
Drum drive system POCLAIN (France)	Pump: axial piston; Motor: radial piston, low speed, high torque
Speed (km/h)	0 – 10,0
Gradeability (theoretical)	35 %
BRAKES	
Service	Dynamic hydrostatic through propulsion system
Parking/Secondary	Spring-applied hydraulically released (SAHR) on each drum drive
WATER SYSTEM	
Type	Pressurized
Pump	Electric, diaphragm
Water tank capacity	110 litres
Filters	Filters 100 mesh screen @ nozzles, 80 mesh in-line
Drum Wipers Type	Spring-loaded, self-adjusting, neoprene wipers
MISCELLANEOUS	
Fuel Capacity	31 litres
Hydraulic Oil Capacity	30,1 litres
Oscillation	+/- 8° +/- 8°
Curb Clearance — Vibration/Traction (mm)	337
Side Clearance (mm)	40

Compaction work with 2 cylinders

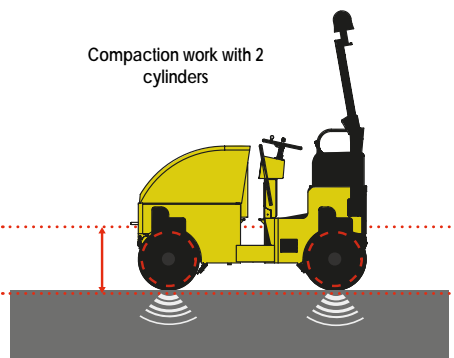

Vibrating drums



Rotating warning light and serial ROPS protection

COMPACTOR

MOBILE EQUIPMENT

CONCRETE EQUIPMENT

SURFACING

CUTTING - GRINDING

Tandem rollers

Roadmaster 1200 is a series of articulated tandem rollers that have vibration and drive on both drums. These rollers are designed primarily for compacting asphalt but their compaction performance is also suitable for sub-bases and base courses. Roadmaster 1200 are designed primarily for smaller construction tasks, such as pavements, bicycle lanes and garage entrances. Roadmaster 1200 are used primarily for the compaction of asphalt on streets and smaller roads in major built-up areas.



Powered by
Kubota

FEATURES AND BENEFITS

- These machines are always fitted with a robust central lifting eye that allows very fast, and simple loading for transportation between different work places.
- A folding Rops (option) means that the transport height can be kept to a minimum.
- The powerful, quiet, water-cooled, three cylinder KUBOTA diesel engine produces 44,9 hp/33 kW. Together with the large drum diameter and the drive motors connected in series, it contributes to excellent accessibility and hill-climbing capacity. Propulsion and vibration naturally come as standard on both drums.
- As an option, it is possible to switch off the vibration on either the front or the rear drum.
- Vibration on both drums with three positions. Lights on both sides of the machine.
- Hydrostatic drive with variable speed.
- Self-cleaning drum for good traction and better surface finish with 2 scrapers.
- Large size water tank for extended use and reduced refill stops, easy cleaning access.
- Silent, powerful water-cooled Kubota diesel engine.
- Large easy-to-open engine hood for easy access.
- Motor Tier 4.

Safety interlock to prevent accidents. Operator must be in the seat before the engine will start.



Poclair hydraulic system

Ergonomic seat

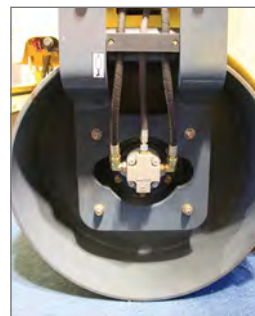

Oil level control

Water control

Adjustable ergonomic steering wheel

Casappa vibration system

Anti-theft central locking mechanism

TANDEM ROLLER RM1200 - ROADMASTER 1200



Powerful and easily accessible 3-cylinder engine, with optimized fuel consumption - low pollution.



Ergonomic Dashboard



Warning light

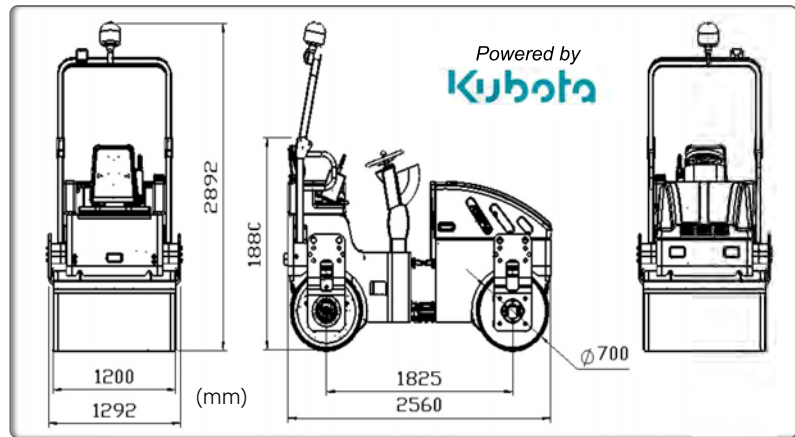

Easy access, protects filter and fuel



Double articulation with lubrication points 'Pac-Pivot' (patented)

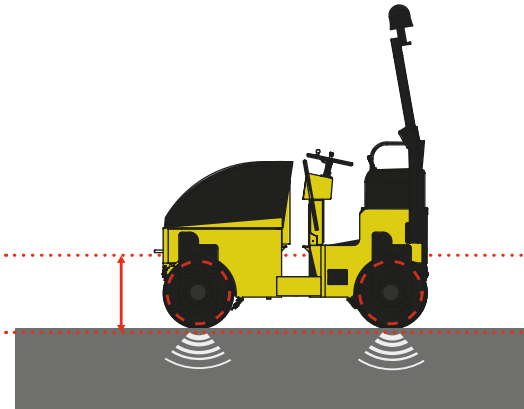

Turbo engine 44 hp to amplify extra power



Hydraulic system line assembled, improves security and full power on cylinders.



Code	RM1200
Model	ROADMASTER 1200
Dimensions L x W x H (mm)	2560 x 1292 x 2892
Operating weight (kg)	2780
Drum size (mm)	700
Progressive speed front/rear (km/h)	0-10
Brakes	Hydrostatic
Brake type	Active Multidisc /negative
Emergency stop	Active Multidisc /negative
Frequency (Hz)	66
Centrifugal force (kN)	50
Amplitude (mm)	0,64
Rolling slope with vibrations (%)	30
Slope without vibration (%)	40
Climbing ability with vibration (°)	35
Engine	KUBOTA V1505-T-E3B-KEA-1 Diesel IDI 4 stroke Water cooled
Power ISO 9249 - hp (kW)	44,9 (33)
Revolutions max. (r/min)	2800
Linear static load front drum (kg/cm)	10,6
Maximum centrifugal force (daN)	2800
Nominal amplitude UNE115-435 (mm)	0,5
Operational mass UNE-115-434 (kg)	2850
Operational mass on front axle (kg)	1425
Certified power SAE J 1349	

COMPACTOR

MOBILE EQUIPMENT

CONCRETE EQUIPMENT

SURFACING

CUTTING - GRINDING

Fully hydrostatic, dual vibration system

The innovative DR8000 walk behind roller helps you limit your machine investment. A double stage high-amplitude setting provides this walk-behind roller the ability to perform on both soil and aggregate surfaces. With the flip of a switch your operator can adjust to a low-amplitude setting and have a roller that is a perfect fit in asphalt and bituminous materials. This roller is equipped with the powerful Hatz 1B50 engine with electric start and easy accessible control panel on steering handle. The drive and vibration are fully hydraulic, eliminating V-belt and clutch. DR8000 features scrapers and a 50-litre water tank with sprinkler system to ensure the machine is ready to handle bituminous surfaces when called upon. This unique PACLITE roller offers perfect clearance on both drum sides, allowing compaction work extremely close to curbstones, retaining walls and other obstacles. No extra time-consuming work on edges and in confined areas is needed. The hydraulic drive ensures variable speed adjustment and smooth starting/braking action.

FEATURES AND BENEFITS

- Two large Poclair hydraulic drive pumps and a vibration pump from Sauer Danfoss
- Air-cooled HATZ diesel engine: powerful and environmentally friendly.
- Hydrostatic drive and vibration system.
- Hydrostatic adjustable excentric weights that are productive in both soil and asphalt applications.
- Hydraulic pump for hydrostatic drive and steering: no V-belt or clutch.
- Ergonomic vibration dampened operator handle, control panel with easy access.
- Hydrostatic control lever and adjusting lever.
- Two removable drum scrapers ensuring automatic cleaning.
- MAXIMUM SAFETY: dead man safety button.
- Hydraulic parking brake, reverse gear limited to 2,5 km/h.
- Adjustable amplitude on asphalt (13 kN) as well as on soil (21 kN).
- Anti-corrosive oil tank.



Powered by

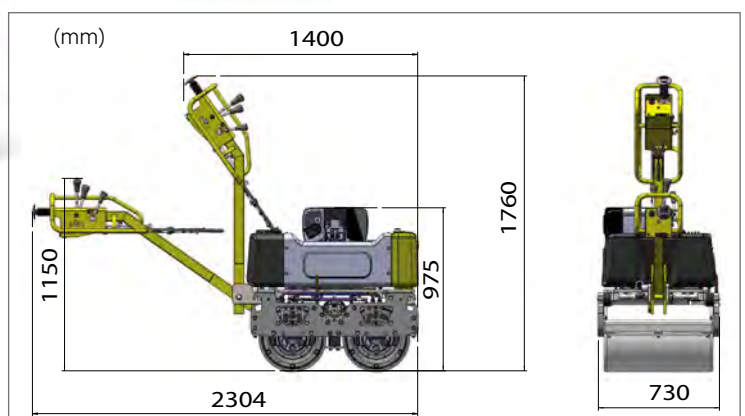



Powered by



+ WEIGHT
+ COMPACTION
+ POWER
+ COMPACT



Code	DR8000H
Model	DR8000
Weight CECE (kg)	770
Working width (mm)	650
Linear charge (kg/cm)	5/28
Drive	Hydrostatic
Diesel engine	Hatz 1B50-V5
Engine power hp (kW)	11,3 (8,5)
Forward speed (km/h)	4
Speed reverse gear (km/h)	2,5
Vibration	Hydrostatic
Centrifugal force to choose (kN)	13/21
Vibration motor brand	Sauer Danfoss
Vibration frequency Hz (vpm)	70 (3300)
Gradeability with/without vibration (%)	25/45
Water tank capacity (L)	50
Hydraulic oil tank (L)	20
Fuel consumption (L/h)	1,2
Hour meter	Option
Protective cover	Yes
Compaction Depth* big or small amplitude	
*According to the nature of the soil	
Sand/gravel (cm)	30/25
Usual soil (cm)	20/15
Sound level dB (A)	95
Hand-arm vibration (m/s ²)	4

COMPACTION

MOBILE EQUIPMENT

CONCRETE EQUIPMENT



All PACLITE models are ergonomically designed and comfortable.



Reinforced thick frame

Operating handle with integrated electronic controls



Excellent performance of compaction of all our models.



Control panel with double amplitude



Switch between two amplitudes

Low amplitude for use on asphalt surfaces. Large amplitude ensures efficient and rapid compaction of sub-base or soil.

SURFACING



Two hydraulic Poclair pumps



Sauer Danfoss Vibration motor

CUTTING - GRINDING

Large duplex rollers 700 and 800 kg

The VR6500KF3 and DRX7800 double drum vibratory rollers are hydraulically driven and intended for both soil and asphalt compaction. The exclusive compact design allows for clearance on both sides of the rollers in tight areas. Plus, the totally hydrostatic drive eliminates mechanical components providing for less maintenance and greater reliability.

The large 47-litre water tank with built-in filters allows for longer service life, reduced maintenance and longer use. It is also equipped with a new 31 litre hydraulic tank to improve the cooling of the machine during prolonged uses.

FEATURES AND BENEFITS

- Choice of highly reliable Hatz or Kubota engines, provides exceptional performance, fuel economy and long life with low maintenance.
- Adjustable scrapers.
- Parking brake.
- Sauer Danfoss hydraulic motors and pumps PV10-619.
- Improved design with lower overhang.
- Rigid square handle.
- Epoxy painted body in 4 stages.



Code	VR6500K5	DRX7800H
Model	VR6500KF3	DRX7800HATZ-5
Operating weight (kg)	700	800
Centrifugal force (kN)	20	21
Dimensions L x W x H (steering bar position) (mm)	2385 x 700 x 1772	2385 x 700 x 1772
Cylinder diameter (mm)	402 x 650	402 x 650
Curb/Wall clearance (right/left) (mm)	25	25
Lateral clearance (right/left) (mm)	235	235
Water tank capacity (litres)	47	47
Side cover	Opening	Opening
Double starter	Electric and manual	Electric and manual
LED service light	Yes	Yes
Frequency (Hz)	65	68
Linear load (dynamic per drum) front/rear (N/mm)	10,0/10,0	12,0/11,0
Hydraulic Pump Sauer-Danfoss axial piston	PV10-619	SPV10-325
Forward speed (m/min)	0-3,6	0 - 4,2
Reverse speed (m/min)	0-2,5	0 - 2,1
Reverse speed limitation down	Integrated	Integrated
Max Gradeability without vibration (%)	28	35
Vibration level (m/s ²)	4	4,2
Sound level dB (A)	89	91

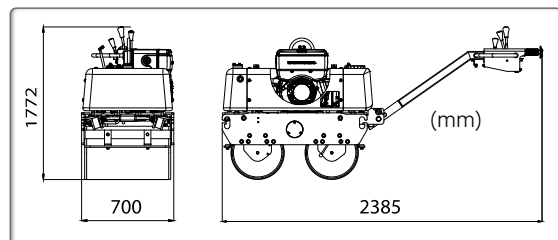

Engine	Kubota	HATZ
Model	EA330-E4NB1 E4NB1 & E75NB3	1B40 -V5
Power hp (kW)	6,5 (4,85)	10 (7,5)
Starter	Electric and manual	
Engine Type	4 stroke	
Cooling	Water	Air
Fuel consumption (l/h)	1,36	1,45
Abgasnorm	Stage 5 CE	-
Certified power SAE J 1349		



Low hand-arm vibration



Improved water tank 47 L



Easy opening hood



Manual start on KUBOTA model

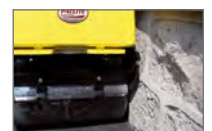

Reduced overhang and improved wall clearance

The world's best trench plate

PX91 vibratory plate compactor features a unique round base that allows flush compaction next to posts, pillars, guardrails, manholes, drainage inlets and foundations.

The design of PX91 makes it easy to manoeuvre around obstacles.

FEATURES AND BENEFITS

- Improved centrifugal clutch.
- Base plate made of hardened ductile steel, type GGG500.
- Oversized heavy duty throttle cable adapted for tough applications.
- Increased vibration frequency, faster and stable.
- Durable epoxy painted surface.

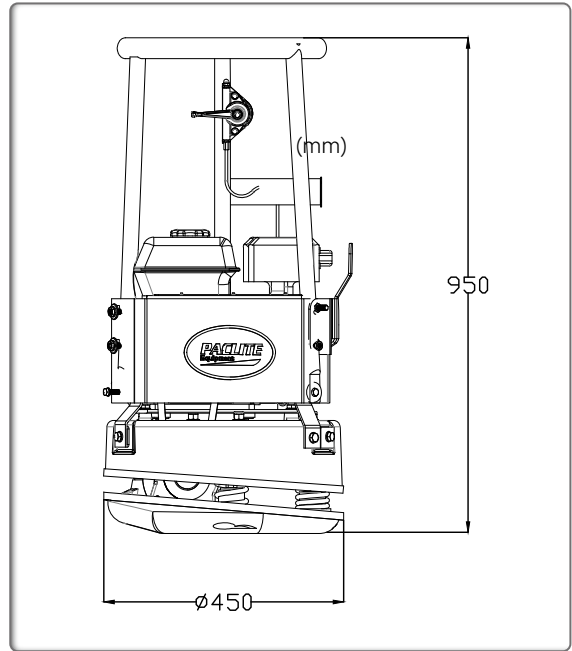

POWERED BY
HONDA

TÜVRheinland

Code	PX91
Model	PX91
Operating mass (kg)	96
Centrifugal force (kN)	15
Plate diameter (mm)	450
Engine	Honda GX160
Net power hp (kW)	4,8 (3,6)
Rated engine speed (rpm)	3600
Fuel tank capacity (L)	3,1
Engine oil capacity (L)	0,6
Fuel consumption at rated power (L/h - rpm)	1,4 - 3600
Speed (m/min)	22
Amplitude (mm)	0,97
Frequency (Hz)	95
Sound pressure level dB (A)	89
Vibrations* (m/s ²)	3,5
*Minimum vibration levels measured to EN500-4	
Certified power SAE J 1349	



Protective frame



Centrally placed throttle



Extended safety cover



Mounted in large series

Reversible plate compactors

A series of reversible plates with an operating width of **600mm**, offer robustness and compact size, and are easy to operate on any construction site.

IMPACT series are equipped with low vibration-isolating handles, ergonomically designed and comfortable.

This equipment combines high efficiency, speed and depth of compaction. The hydraulic servo-control acts on the vibrating element, providing smooth uniform movement and easy driving. The low vibration handle constitutes one of the most important advantages of this plate.

It is fixed on specially designed shock absorbing blocks with exceptional compaction parameters (strength centrifuge: 30 kN), providing excellent results for the compaction of granular materials in trenches, foundation and road repair projects.

FEATURES AND BENEFITS

- Lifelong lubricated bearings for extended service life.
- Exciter bearing design requires minimal maintenance for improved productivity.
- Strong V-belt cover.
- 30 kN excentric element.
- Convenient single lifting point.
- Standard engine: Honda 4-stroke or Hatz Diesel.
- Engine with oil alert on all models.
- Option: electric start.
- Low hand-arm vibration handle.



MOULDED BOTTOM PLATE

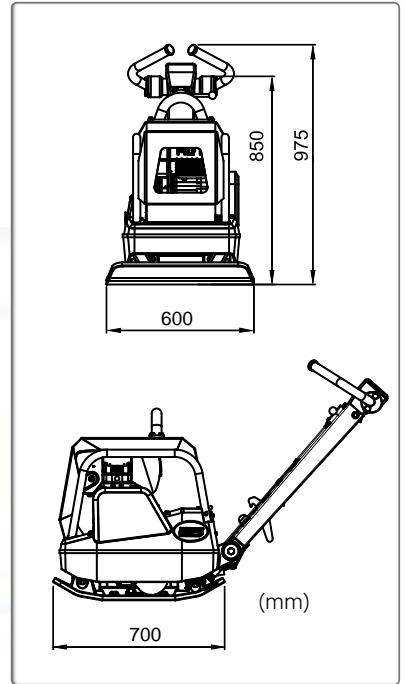

Powered by



IMPACT 230 with electric starter



Handle with integrated electric starter box



Low hand-arm vibration handle

Code	IMP200D	IMP230DEHS
Model	IMPACT 200	IMPACT 230
Engine	Hatz 1B20	Hatz 1B20
Net power hp (kW)	4,6 (3,5)	4,6 (3,5)
Max. Engine speed (rpm/min)	3300	3300
Plate dimensions L x W (mm)	700 x 600	700 x 600
Operating weight (kg)	230	238
Centrifugal force (kN)	30	30
Operating speed (m/min)	21	21
Compacted area (m ² /h)	630	630
Frequency (Hz)	90	90
Start	Manual	Electric
Vibrations* m/sec ² /utilisation (hrs)	3,5/4,33	2,8/4,33
Sound pressure level dB (A)	105	105
* Minimum vibration levels measured to EN500-4		
Certified power SAE J 1349		

Reversible plate

The most modern and compact design with increased speed to allow greater compaction capacity and designed to meet the toughest job conditions. PACLITE compact series forward/reverse vibratory plate with excellent compaction data.

Speed and compaction depths are regulated seamlessly via hydraulic servo-control of the excentric element. This gives the plate smooth motion and makes it very easy to operate. All-round plates for compaction work close to piles and concrete bases. Also for floor filling and foundations as well as backfill in pipe trenches.

FEATURES AND BENEFITS

- Increased forward travel speed for greater surface capacity.
- The same forward and reverse speed produces more consistent results, e.g. in plaster compaction.
- Reinforced covers and fastening elements for increased protection and thus lower maintenance costs.
- The moulded bottom plate is made of wear resistant steel GJS-700.
- Long operating times thanks to low hand-arm vibrations.
- Lifting point.
- Engine with oil alert on all models.
- The handle can be positioned vertically for better manoeuvrability.
- Optimized rubber shock mounts reduces hand-arm vibrations transmitted to the operator.
- Loading to trucks or placement in trenches are facilitated by a strong lifting eye.
- Stop alarm engaged when engine is on "stop".



Electric start



Manual dual starter



Low HAV handle with rubber mounts and servo control



Easy access for battery service and jump start

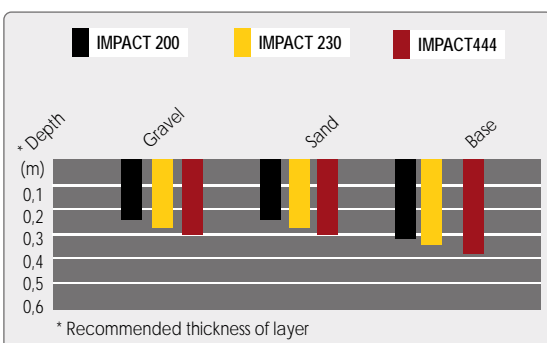
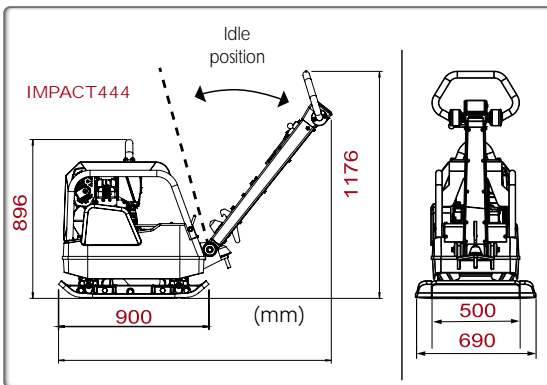

Powered by



Code	IMP444DHE5
Model	IMPACT 444
Dimensions L x W (mm)	1671 x 690 x 1153
Operating weight (kg)	465
Centrifugal force (kN)	55
Working width (without extensions) (mm)	500 + 2 x 95
Thickness of bottom plate (mm)	12
Operating speed (m/min)	26
Compacted area (m ² /h)	912
Frequency (Hz)	80
Engine	Hatz diesel 1B40-V5
Engine power hp (kW)	10 (7,5)
Power (rpm)	2900-3600
Engine consumption (l/h)	1,8
Engine single cylinder	Air-cooled
Start	Electric and auxiliary rope
Automatic cut-off in case of lack of oil	Yes
Hand-arm vibration* (m/s ²)	3,1
Vibrations* m/s ² /utilisation (hrs)	3,2/4,53
* Minimum vibration levels measured to EN500-4	
Certified power SAE J 1349	

High capacity asphalt plate compactor

Segregation in materials can be a big problem. There are a number of emerging technologies in asphalt compaction that allow for the manipulation of binder viscosity and thus lower mixing and paving temperatures through chemical modification. This creates a demand for specially designed machines for use on the various types of asphalt layers.

PACLITE compactors minimize segregation problems and promote homogeneity of material and air void distributions within the compacted layers.



POWERED by
HONDA
norm SAE J1349

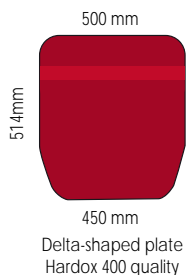
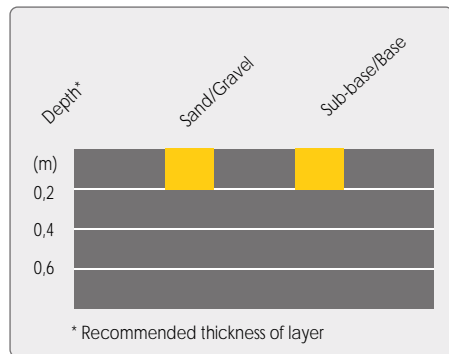

System to reduce HAV
(Hand-arm Vibration)

FEATURES AND BENEFITS

- High strength aluminium components including the engine console and belt guard have been combined for reduced weight and easy machine handling.
- Straight, centre-mounted guide handle offers superior manoeuvrability and can be lowered within inches of the surface to operate plate under obstacles and form work.
- High rate of travel due to well designed base plate geometry and good weight distribution.
- Design for outstanding handling especially in confined conditions.
- Large removable water filter located inside of water tank prevents clogging during operation and can be easily removed by sliding off the attachment for filling and draining.
- Angled holes on spray bar allow complete water coverage for no asphalt pick-up on plate bottom.
- Special Delta shaped bottom plate for compaction and moving of thin asphalt layers.

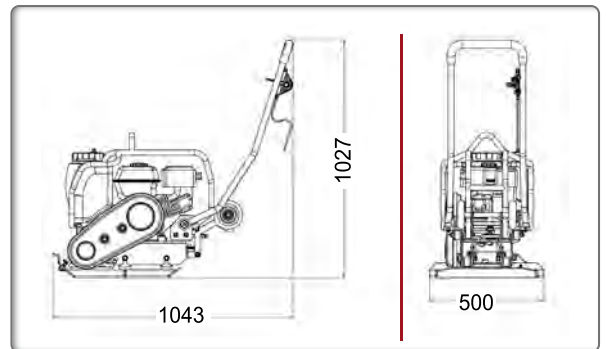

Code	PX5.0A
Model	VECTOR PX5.0
Operating mass (kg)	77
Centrifugal force (kN)	12
Plate width (mm)	500
Engine brand	Honda GX160
Net power hp (kW)	4,8 (3,6)
Rated engine speed (rpm)	3600
Fuel tank capacity (L)	3,1
Engine oil capacity (L)	0,6
Fuel consumption at rated power (L/h - rpm)	1,4 - 3600
Water tank (L)	13
Speed (m/min)	21
Amplitude (mm)	0,9
Frequency (Hz)	95
Sound pressure level dB (A)	91
Vibrations* (m/s²)	3,5
* Minimum vibration levels measured to EN500-4	
Certified power SAE J 1349	

Professional compacting of slabs, pavers and natural stone

The perfect solution for compacting stone pavers in all kind of formats and materials.

A high capacity machine that levels and compacts stones without breaking the material or edges.

This machine has been designed specifically for the challenging task of compacting slabs, pavers and natural stone. ROLL PAV produces vibration over surfaces with exceptional ease and gentleness. The smooth mode of operation embeds the material properly, while preventing shifting, cracking or chipping of stones. It minimizes dust that usually is created from compacting polymeric jointing sands. Polyurethane rubber coated rollers protect the surface at all times.

FEATURES AND BENEFITS

- Suitable for compacting pavers and slabs of large format.
- Allows compaction without scratching the slab or pavement.
- Effective work even in hard to reach areas.
- Optimal weight distribution thanks to the four polyurethane rollers.
- Throttle mounted on the foldable operating handle.
- Centrally placed lifting eye.
- Honda GX160 engine.



Code	ROL-GX160
Model	ROLL PAV 120
Dimensions L x W x H (mm)	1067 x 700 x 1089
Operating weight (kg)	123
Surface size L x W (mm)	655 x 620
Vibration frequency (Hz)	110
Centrifugal force (kN)	14,5
Compaction area (m ² /h)	600-700
Engine	Honda GX160
Net power hp (kW)	4,8 (3,6)
Rated engine speed (rpm)	3600
Fuel tank capacity (L)	3,1
Engine oil capacity (L)	0,6
Fuel consumption at rated power (L/h - rpm)	1,4 - 3600
Hand-arm vibration* (m/s ²)	3
Vibrations* m/sec ² /utilisation (hrs)	3,1
Certified power SAE J 1349	

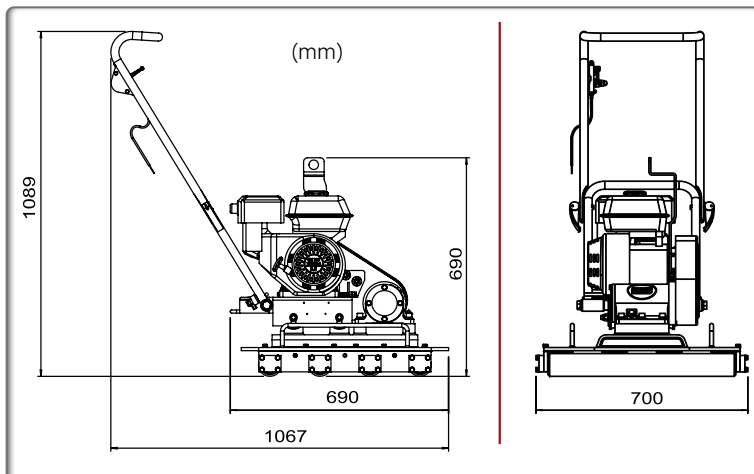

Heavy forward plate - gasoline or diesel

PACLITE vibratory plates offer functionality and performance at a value price. Compact design allows for compaction of mixed soils in the narrowest of spaces - even in extremely narrow trenches. Ideal for curbs, gutters, around tanks, forms, columns, footings, guard railings, drainage ditches, gas, sewer works and building construction.

These plates are optimally suited for a variety of compaction applications thanks to their high speed of advance and simple manoeuvrability.

Two types of engines available: gasoline and diesel.

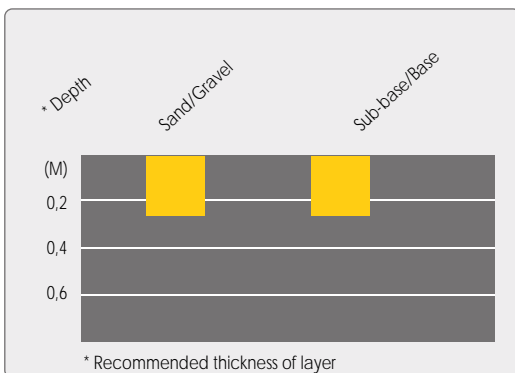

FEATURES AND BENEFITS

- Newly designed "low-vibration" guide handle greatly improves operator comfort and minimizes operator fatigue.
- Completely enclosed belt protected by a lightweight belt guard for reduced wear and minimal service.
- Ergonomically designed lifting handles make loading and unloading from transport vehicles easier for the operator.
- Durable shock mounts on engine console dampen vibrations thereby reducing wear on the components.
- Devibrated handle with 'cup design' to reduce hand-arm vibration.
- Transport wheels and water kit included.
- Throttle mounted on the operating handle.

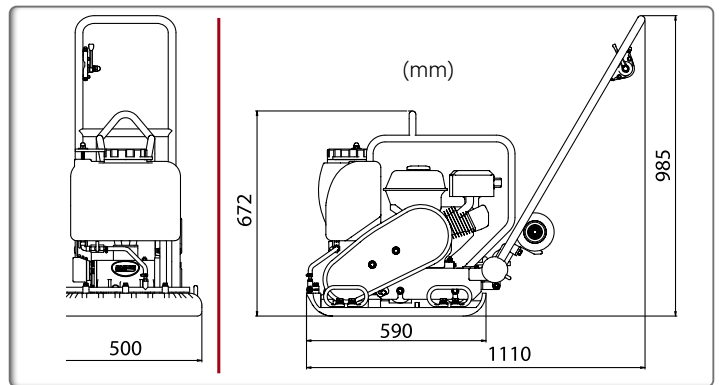

Code (CE)	PC100H	PC100DH
Model	PC100 Honda	PC100 Hatz
Operating mass (kg)	96	125
Centrifugal force (kN)	20	20
Plate width (mm)	500	500
Engine brand	Honda GX160 Gasoline	Hatz 1B20-V5 Diesel
Net power hp (kW)	4,8 (3,6)	4,7 (3,46)
Rated engine speed (rpm)	3600	3100
Fuel tank capacity (L)	3,1	3,5
Fuel consumption at rated power (L/h - rpm)	1,4 - 3600	0,7
Water tank (L)	13	13
Speed (m/min)	25	26
Amplitude (mm)	0,95	0,9
Frequency (Hz)	95	90
Sound pressure level dB (A)	91	101
Vibrations* / (m/s²)	3,94	3,94
Surface capacity (m²/h)	750	750
* Minimum vibration levels measured to EN500-4		
Certified power SAE J 1349		

OPTION : PAVING PAD	
Code	PPV-PAD100

Transport wheels included



Versatile, high performance forward plate compactor

Premium asphalt plates feature a durable base plate for various applications. A true combination plate for various applications in the 85-90kg weight class.

Designed for the compaction of granular and mixed materials with some cohesive content in confined areas such as parking lots, highway and bridge construction, next to structures, curbs, and abutments. This computer designed base plate has a tapered bottom and edges for high speed and excellent manoeuvrability.

FEATURES AND BENEFITS

- Straight, centre-mounted guide handle offers superior manoeuvrability and can be lowered within inches of the surface to operate plate under obstacles and form work.
- Many lifting points and front lift cage offer easier loading and unloading for operator convenience.
- Compact design, easy to use, cast bottom plate.
- Smooth and flexible.
- Throttle mounted on the operating handle.

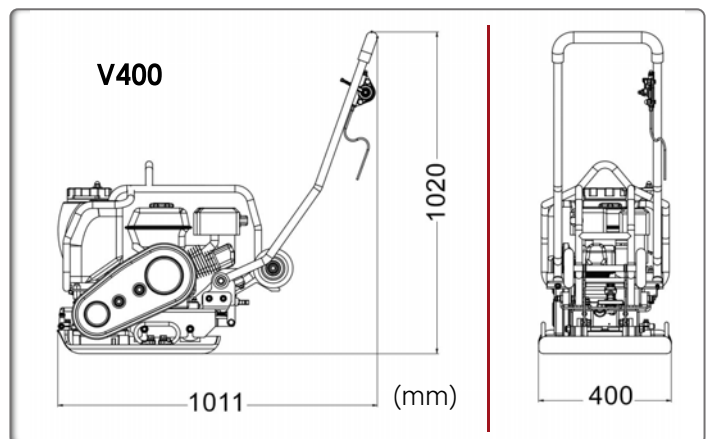
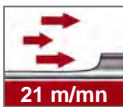

Code	V400COMBI	V400-ECO
Model	V400 COMBI	V400 ECOPOWER
Operating mass (kg)	92	97
Centrifugal force (kN)	14	14
Plate width (mm)	400	400
Engine	Honda GX160	Honda EGX
Net power hp (kW)	4,8 (3,6)	2,4 (1,8)
Rated engine speed (rpm)	3600	3600
Fuel tank capacity (L)	3,1	-
Engine oil capacity (L)	0,6	-
Fuel consumption at rated power (L/h - rpm)	1,4 - 3600	-
Water tank (L)	13	13
Speed (m/min)	21	25
Amplitude (mm)	0,89	0,89
Frequency (Hz)	95	95
Sound pressure level dB (A)	91	55
Vibrations* (m/s²)	2,62	3,62
Surface capacity (m²/h)	685	805

* Minimum vibration levels measured to EN500-4
Certified power SAE J 1349

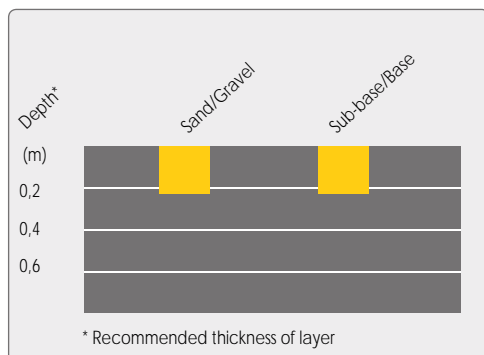

OPTION : PAVING PAD	
Code	PPV-PAD400
	PPV-PAD450



Option: Accessory - stone paving pad, essential accessory for the installation of slabs or pavers.

COMPACTOR

MOBILE EQUIPMENT

CONCRETE EQUIPMENT

SURFACING

CUTTING - GRINDING

A Premium asphalt plate with moulded base plate for various applications

PACLITE PC60 feature a tough, wear resistant, ductile iron base plate offering high strength and shock resistance. This computer designed base plate has a tapered bottom and edges for high speed and excellent manoeuvrability.

Designed for the compaction of granular and mixed materials with some cohesive content in confined areas such as parking lots, highway and bridge construction, next to structures, curbs, and abutments.

FEATURES AND BENEFITS

- Special contoured running surfaces and rounded edges provide maximum performance and manoeuvrability.
- Completely enclosed belt protected by a lightweight belt guard for reduced wear and minimal service.
- Newly designed "low-vibration" guide moulded handle due to the 'cup design' greatly improves operator comfort and minimizes operator fatigue.
- Heavy-duty shock mounts on engine console dampen vibrations thereby reducing wear on the components.
- Exciter bearing design requires minimal maintenance for improved productivity.
- Standard package Honda GX160 water kit and transport wheels.
- Low HAV mechanism.
- Throttle mounted on the operating handle.



POWERED by
HONDA
norm SAE J1349



E-version coming soon!

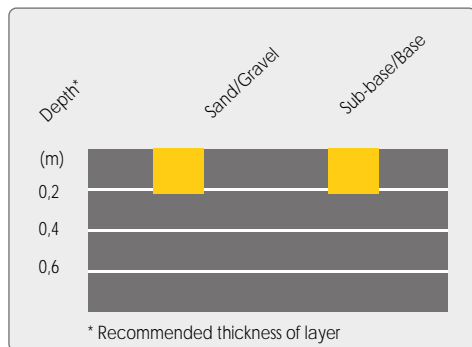
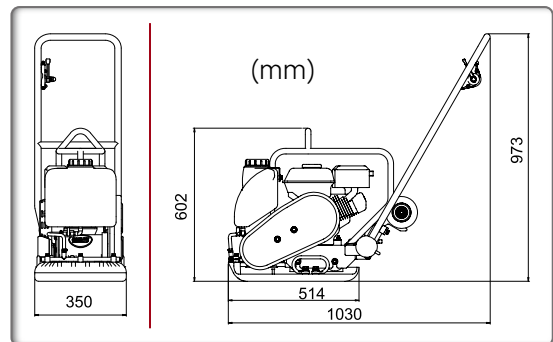

Code	PC60H
Model	PC60
Operating mass (kg)	66
Centrifugal force (kN)	11
Plate width (mm)	350
Engine	Honda GX160
Net power hp (kW)	4,8 (3,6)
Rated engine speed (rpm)	3600
Fuel tank capacity (L)	3,1
Fuel consumption at rated power (L/h - rpm)	1,4 - 3600
Water tank (L)	8
Speed (m/min)	20
Amplitude (mm)	0,9
Frequency (Hz)	95
Sound pressure level dB (A)	88
Vibrations (m/s ²) *	3,9
Surface capacity (m ² /h)	630
* Minimum vibration levels measured to EN500-4	
Certified power SAE J 1349	



Perfectly balanced and designed for the toughest job sites.



Transport wheels included

OPTION : PAVING PAD

Code	PPV-PAD60
------	-----------



Optimum paving protection of paving stones during compaction work. Essential accessory for paving slabs or paving stones.

Extra light-weight compactor

Designed for repair in confined areas. These plates are ideal for curbs, gutters, block paving around houses, tanks, forms, columns, footings, guard railings, drainage ditches, gas and sewer lines, and building works.



Ultra compact design

POWERED by
HONDA
norm SAE J1349



FEATURES AND BENEFITS

- Special contoured surfaces, rounded edges and its low weight provide maximum performance and manoeuvrability.
- Completely enclosed belt protected by a light-weight belt guard for reduced wear and minimal service.
- Exciter bearing design requires minimal maintenance for improved productivity.
- Ergonomically designed foldable handles offer easier loading and unloading for operator during transport.
- Low HAV mechanism.
- Throttle cable mounted on the operator handle.

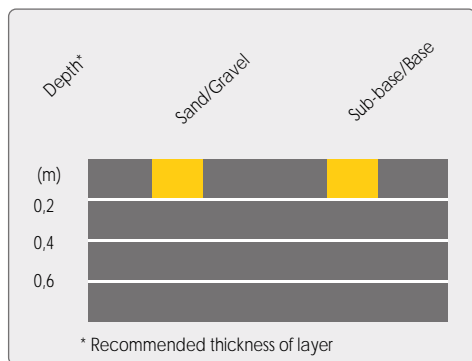
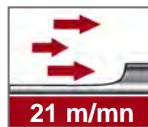
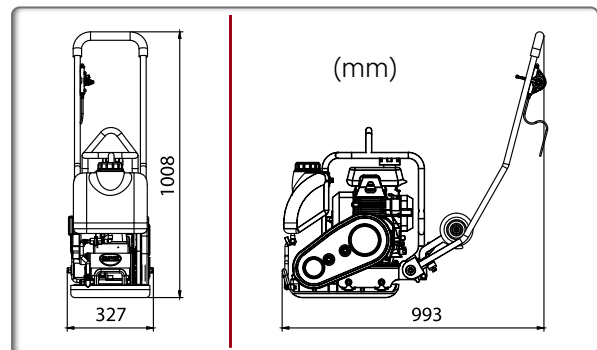

Code	LCC40W
Model	LCC40W
Operating mass (kg)	45
Centrifugal force (kN)	11,5
Plate width (mm)	320
Engine	Honda GXR120
Power hp (kW)	3,5 (3)
Water tank (L)	6
Speed (m/min)	21
Amplitude (mm)	0,89
Frequency (Hz)	95
Sound pressure level dB (A)	89
Surface capacity (m ² /h)	525
Vibrations* (m/s ²)	3
* Minimum vibration levels measured to EN500-4	
Certified power SAE J 1349	



Transport wheels included

Vibrating plate and rammer with Honda battery

PACLITE's battery-powered vibratory plates and rammers operate emission free and therefore suitable for many sensitive compaction or trenching applications. These machines are equipped with battery-powered Honda engines that provides a full day of compaction work time. Their performance is equal to those of conventional engines. The vibrating plates are always equipped with a watering kit and transport wheels.

FEATURES AND BENEFITS

- Great surfacing capacity.
- Electric motor, with proven timing belt, for zero maintenance and very low service costs.
- The emission-free engine protects the operator on all construction sites and opens up new fields of application indoors and in areas where emissions are regulated (city centres).
- Low energy cost for a **saving of approximately 75% for the V400 and 65% for the CRX698** compared to petrol machines in the same weight range.
- **100% zero emission work.**
- Reliable starting in any weather and at any altitude: Just press a button.
- The battery can be used with other PACLITE vibratory plates.

POWERED by
HONDA

eGX



Code (CE)	GXE2.0H	Code (CE)	DP72104Z	Code (CE)	CV7285Z
Model	V400 / CX698 Motor E-GX ECO battery	Model	Battery	Model	Rapid charger
Type	DC, brushless, three-phase, forced air-cooled permanent magnet	Type	Lithium battery ion rechargeable	Type	Constant voltage and current fast charger, forced air cooling
Net power kW (HP) rpm	1,8 (2,4) 3600	Voltage (V)	72 continuous	Voltage (V)	100 to 240 alternative
Control	PWM 3 phases	Available energy (Wh)	720	Frequency (Hz)	50/60
Regulated current (A/V)	27 / 72	Nominal capacity (Ah)	10	Tension (V)	82,8 continuous
Compatible battery	DP72104Z	Dimensions L x W x H (mm)	233 x 268 x 150	Output current (A)	8,5
Compatible charger	CV7285Z	Weight (kg)	6,4	Dimensions L x W x H (mm)	272 x 352 x 270
Dimensions with battery L x W x H (mm)	294 x 353 x 420			Weight (kg)	11,2
Weight with battery (kg)	26,1				



CRX698 RAMMER & NEW CRX698 ECOPOWER RAMMER*

Fully anti-vibration operator handle



Work in absolute comfort, low hand-arm vibration, unique in the industry.

The CRX698 is the first low-vibration hand-arm rammer in the market. It has exceptional characteristics such as flexibility, high and powerful percussion for perfect stability at work.

Honda GXR120 engines (air-cooled, drive shaft horizontal power take-off, cast iron jacketed cylinder with carburettor diaphragm) enable very high performance.

A unique air filtration system, at three levels: first, a cyclonic filter which absorbs the raw materials, then an air filter and then the filter in the Honda engine. Its design keeps the engine practically dust-free and gives it a remarkable lifespan.

The sole of the foot is handcrafted from laminated wood and steel, providing flexibility and endurance. The rammer CX698 has a replaceable (patent-pending) one-piece piston with molded Teflon trim that doubles its life.

FEATURES AND BENEFITS

- Remarkable flexibility and working comfort.
- Cyclone air pre-filter for five times less maintenance intervals.
- Automatic oil level control.
- Easy access points for engine maintenance.
- Anti-vibration handle, the lowest vibration rate in the labor force industry.
- Engine speed indicator and hour meter.
- Protective cover fitted with a tachometer.
- Central sling ring.
- Wheels mounted on the drawbar for loading.
- Engine stop integrated on the handle.
- 380 mm narrow frame.
- Bellow and foot of German fabrication.
- Honda GXR120 engines.
- Available with battery motor EGX honda.

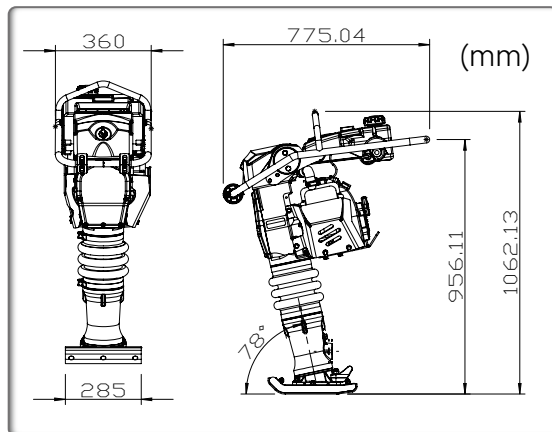

170 x 135 mm
Interchangeable rammer shoe

Code	CRX698-HAV	CRX698-ECO
Model	CRX698-4 HONDA	CRX698 ECOPOWER
Operating weight (kg)	68	71
Plate width (mm)	335-285	335-285
Engine	Honda GXR120	Honda EGX
Power hp (kW)	3,1 (2,3)	2,4 (1,8)
Engine speed (rpm)	3600	3600
Cylinder (cm³)	121	-
Consumption of fuel (l/h)	1,1	-
Speed (m/min)	8 - 15	8 - 15
Amplitude (mm)	70 - 85	70 - 85
Frequency (Hz)	12	12
Centrifugal force (kN)	18	18
Sound pressure level dB (A)	104	45
Percussion rate max. (blows/min)	640	640
Operating speed (m/min)	8,9	8,9
Surface capacity compaction (m²/h)	149	149
Vibration emission value* (m/s²)	3,2	-
CO2 (NRSC) (g/kWh)	655	-
Hand-arm vibration* (m/s²)	3,1	6,2
* Minimum vibration levels measured to EN500-4 Certified power SAE J 1349		

OPTIONS		
Code	CR/SHOE-170	CR/CR-WHEEL
Model	Interchangeable rammer shoe 170 x 135 mm	Transport wheel kit



Wheel kit OPTION



Tachymeter



Cyclone filter

COMPACTIION

MOBILE EQUIPMENT

CONCRETE EQUIPMENT

SURFACING

CUTTING - GRINDING

Multiple use rammer

TR740 - A rammer with a rugged design for multiple uses. This rammer is suitable for applications on both granular and cohesive soils, where strict requirements are imposed for compaction in confined areas, trenches and repair work.

TR800D - This standard PACLITE **diesel rammer** offers maximum production, performance and durability while providing you the convenience of standardizing your diesel fleet. A well-balanced machine for easy handling and operation.

The TR800D is the heavyweight amongst the rammers and is exceptionally reliable because of its engine. Its preferred use is on soils which are difficult to compact, on sites where solely diesel fuel is used to avoid the accidental mix up of fuels and also on various repair jobs.

FEATURES AND BENEFITS

TR740

- Strong protective frame and engine support.
- Transports in any position.
- A unique three-stage air filtration system provides a virtually dust-free engine for longer life and improved durability.

TR800D

- A durable HATZ 1B20 diesel engine provides exceptional performance, fuel economy and long life.
- The large capacity fuel tank with self-cleaning in-tank filter, offers long life and minimum maintenance.
- Exclusive noise reducing cover lowers the amount of engine and shoe noise transmitted to the operator.
- New clutch system from German Amsbeck.

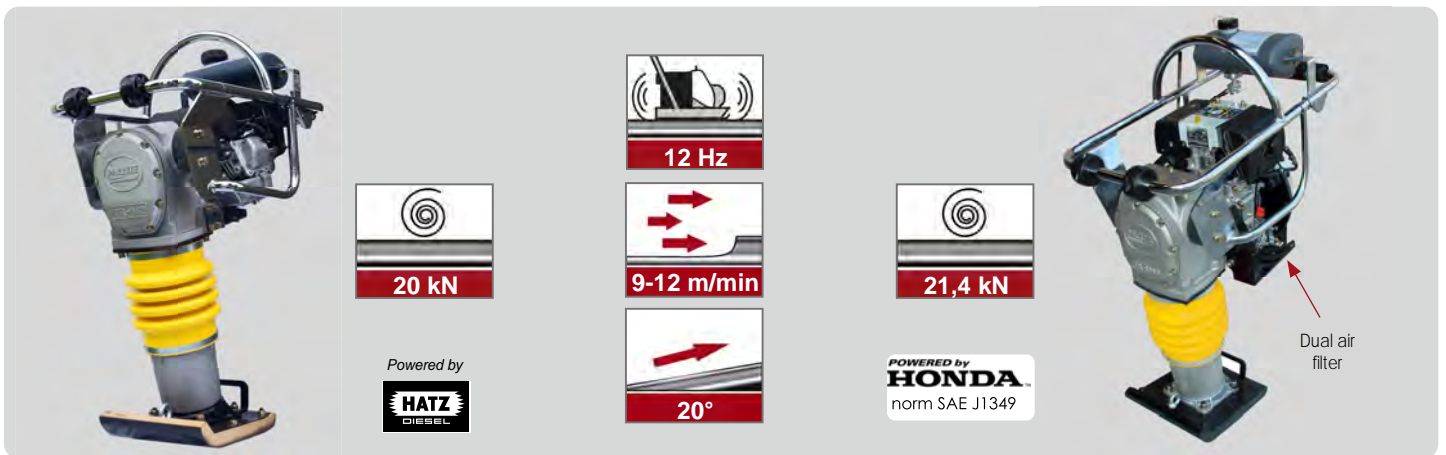

TR740

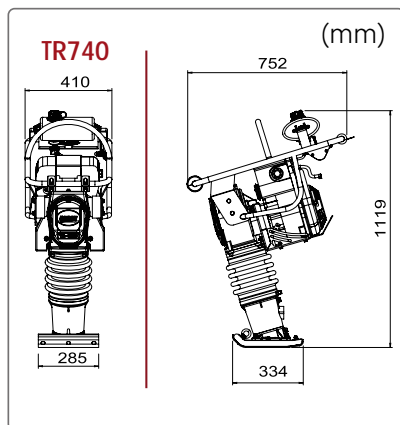

Wood laminated foot

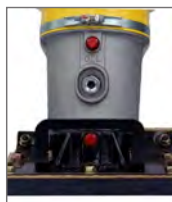

Oil level gauge



TR800D

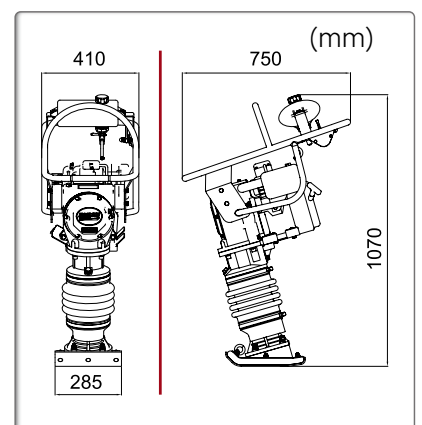

Code	TR740H	TR800D
Model	TR740	TR800D
Operating weight (kg)	70	84
Centrifugal force (kN)	20	21,4
Plate size (mm)	335-285	334 x 285
Engine	Honda GX120	Hatz 1B20 -V5
Power hp (kW)	3,2 (2,4)	4,6 (3,5)
Speed (m/min)	9 - 12	9 - 12
Amplitude (mm)	65 - 75	75 - 85
Frequency (Hz)	12	12
Sound level dB (A)	104	92
Percussion rate max. (Blows/min)	690	690
Surface capacity compaction (m ² /h)	123	123
Operating speed (m/min)	7,5	7,5
Vibrations* (m/s ²)	4,9	9,6
* Minimum vibration levels measured to EN500-4		
Certified power SAE J 1349		

TR740 / TR800D

Wheel kit OPTION
Code OP/TR-WHEEL



MOBILE LIGHTS, PUMPING, DEMOLITION, GENERATORS

The greatest tower lights in the industry

PAC-LIGHT PL2000 ECOLED V6

**MAXI LIGHT
PLUG-IN LED & GO HYBRID**



PAC-LIGHT PL4000

Pumps

PFP80



WP80



Terrain loader



HTL350



DM500

Pneumatic Breakers

PAC-TEC



PAC-TEC05

PAC-TEC11

PAC-TEC21

PAC-TEC24HAV

PAC-TEC29HAV

PAC-TEC32

Insulated Soil Pick

PAC PIO3.0

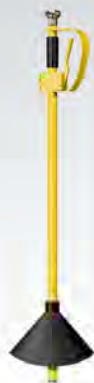

POLE SCABLERS

POLE-PAC



PACLITE Generators

PAC-GEN



Automatic hydraulic mast, towable mast version on road, with brakes, adjustable handle.

Model Version Code	PAC-LIGHT PL2000 ECO LED V6	
	With brakes- Towable CE certified	Manual no road tow
	PL2000 V6-TB	PL2000 V6-TD
Rated frequency (Hz)	Dual 50/60	
Rated voltage (V)	230	
Rated power LED (W)	4 x 350	
Illuminated areas (m²)	5000	
4 LED Lamps DIALUX (kW)	1,4	
Fuel tank capacity (L)	110	
Total weight empty (kg)	676	
Operating temperature min/max (°C)	- 5/50	
Sound pressure Level @ 7 m (LPA)	65	
ENGINE HATZ DIESEL WITH BUILT-IN ALTERNATOR		
Model	1B30-V5 PMG	
Cylinder	1	
Speed (rpm)	2300 -3000	
Rated net output (PRP) Hp (kW)	7,2 (5,4)	
Coolant	Air	
Emergency stop	Yes	
Hour meter	Yes	
Fuel consumption, lamps on continuous (L/h)	0,55	
ALTERNATOR BRAND HATZ		
Specific fuel consumption (g/kWh)	245	
Overhead power (kW)	0,2	
1 fuel tank 110 L continuous run (h)	190	
LIGHTS TYP DIALUX		
Luminous Flux (lumen)	170 000	
HYDRAULIC MAST		
Rotation (°)	345	
Maximum height (m)	8	
Maximum Speed wind (km/h)	80	
TRAILER DIMENSIONS		
Minimum dimensions (L x W x H) (mm)	2900 x 1300 x 2900	
Max. dimensions (L x W x H) (mm)	2900 x 2460 x 8000	
Certified EU for roads	Yes	
Earth grounded cable	Yes	
Type of driving license	B	
Certified power SAE J 1349		

Applications

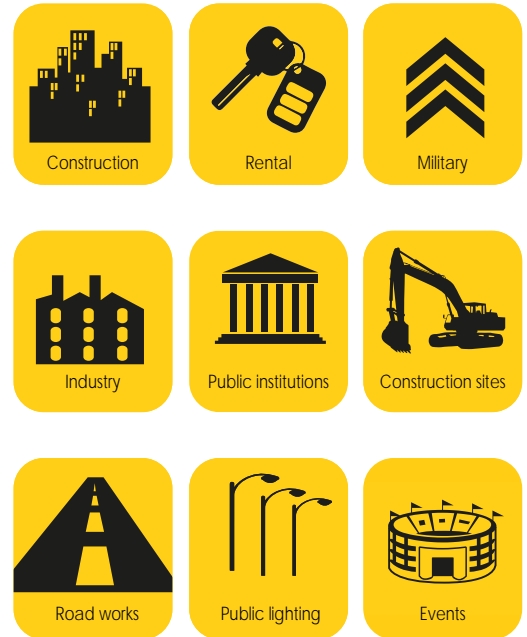

ILLUMINATED AREAS



PAC-LIGHT PL2000 ECO LED V6

Towable on road or manual site tow



INNOVATION!

PAC-LIGHT ECO PL2000 LED V6 offers the latest design and lowest fuel consumption in LED light towers that construction sites, outdoor events and industries around the world have been asking for.

We have coupled the lowest fuel consumption with the market's most powerful 4 x 350W LED DIALUX lamps ever before seen. These products provide outstanding value and efficiency for our customers.

Automatic Hydraulic mast, towable mast version on the road, braked or non-braked versions, adjustable handle.

FEATURES AND BENEFITS

- Centrally placed lifting points and inserts for forklift.
- Compact dimensions in transport thanks to its telescopic design.
- Epoxy powder paint for hardness and strength, the best against ultraviolet light and corrosion.
- Double brakes: manual brake for parking and automatic when towing.
- Towbar adjustable to height.
- Specific paint for rental companies.
- 230 volt socket (10A).
- Hour meter coupled to the motor.



Powered by



ROAD TOW

INNOVATIVE ARGUMENTS

High-powered lighting with 4 LED 350 W lamps.

Low Fuel consumption for 160 hours of continuous operation on one single fuel tank.

Low Fuel consumption (only 0,55 l/h).

Hydraulic mast extends up to 8 m.

< 750 kg towable with 'A' type driving licence.



X 4



350 W

DIALux



Service hood, carbon components to reduce weight



Option : tow brakes



Hand brake and height adjustment

COMPACTON

MOBILE EQUIPMENT

CONCRETE EQUIPMENT

SURFACING

CUTTING - GRINDING

Tower light with vertical mast

PACLITE offers this model with powerful lighting. Four 1000w Metal Halide bulbs that provide a total lighting power of 360,000 lumens. These projector lamps can perform for up to 10,000 hours of use.

The PL4000W is manufactured with the highest quality components and finish; compact design, safe, efficient and high-performance. The unit offers a wider area of illumination and greater fuel economy. Pac-Light has whisper quiet noise levels (just 63 dBA at 7 m) and a large fuel tank, which makes it ideally suited for outdoor events.

The Pac-Light is perfect for providing static lighting needed in the following applications : construction, rental companies, construction of mining infrastructure, large-scale projects, outdoor events.

Powered by highly reliable KOHLER or RAYWIN diesel engines and MeccAlte alternator.

This mechanical model is equipped with a manual winch and telescopic mast which enable a compact design and economy.

FEATURES AND BENEFITS

- Extraordinary product finish with carbon and steel fibre canopy, reducing the overall machine weight.
- High quality European components.
- Four projector lights from GVISS.
- Compact design and strong tow frame.
- Low noise Lombardini water cooled engine. Large back hood with fan provide spacious exhaust for heat.
- One extra socket allows the use of power tools or to connect additional lights.
- Two height adjustable galvanized stabilizers ensure stability of the machine and can withstand up to 80 km/h wind with the mast fully assembled.
- Adjustable jacks balance the machine on rough terrain precisely to 180° against the ground.
- Electrical coiled cable.
- The machine is equipped with forklift pockets and lifting hooks for easy loading for transport.

ILLUMINATED AREA

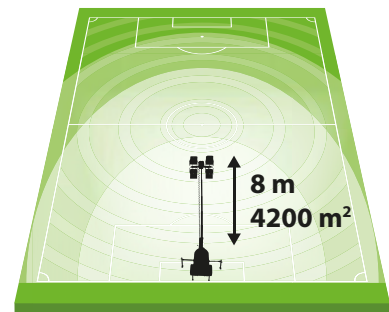

Projectors manufactured in Italy by

Professional's choice

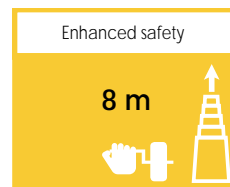

Telescopic vertical mast



Hour meter



Forklift pockets and lifting hooks for easy loading for transport



Control box with one power outlet socket CE

Construction, rental companies, infrastructure & mining

Code	PL4000W-50HZ	PL4000W-60Hz	PL4000-60HZ RW
Modell	PL4000 KOHLER		PL4000 RAYWIN DIESEL
STRUCTURE			
Maximum height (m)	8		8
Raising	Manual		Manual
Rotation Section (°)	340		340
Total lumen (lm)	360000		360000
Illuminated areas (m ²)	4200		4200
Maximum wind stability (km/h)	110		110
Minimum dimension L x W x H (mm)	2650 x 1300 x 2460		2650 x 1300 x 2460
Maximum dimension L x W x H (mm)	2650 x 2460 x 8000		2650 x 2460 x 8000
Operation weight (kg)	900		920
ENGINE			
Engine	KOHLER LDW 1003		RAYWIN 3D11G1/A
Outlet socket (kVA/V/Hz)	1/220/50 – 1/240/60		1/220/50 – 1/240/60
Number of cylinders	3		3
Displacement	1028 cc		1011
Power hp (kW)	17 (12,5)		15,8 (11)
Cooling	Water		Water
Engine rotation speed at 50/60Hz (rpm)	1500		1800
Fuel	Diesel		Diesel
Starting system	Electric		Electric 12 V 1,2 kW
Oil sump capacity (L)	2,4		2,4
Fuel tank capacity (L)	80		80
Duration (h)	54		54
Consumption (g/kWh)	263		255
Noise level (Lwa)	67		62
Battery (Ah)	12 V (55)		12 V (55)
GENERATOR			
Single phase voltage Mecc Alte (kVA-V)	10 kVA-240 V		10 kVA-240 V
Frequency (Hz)	50 - 60		50 - 60
Power factor (Cosφ)	0,8		0,8
Mechanical protection	IP 21		IP 21
LAMP			
Type of light	Metal halide floodlight		Metal halide floodlight
Number & power of light	4 x 1000 W		4 x 1000 W
Degree of protection	IP 66		IP 66
Body construction material	Die-cast aluminium		Die-cast aluminium
Lamp holder construction material	Ceramic		Ceramic
Reflector	Polished and anodized aluminium 99,85		Polished & anodized aluminium 99,85
Cable gland	Stainless steel		Stainless steel
Optical case opening system	Stainless steel clips		Stainless steel clips
Dimensions L x H x D (mm)	404 x 260 x 328		404 x 260 x 328

Certified power SAE J 1349



Lifting points



Easy opening rear hood



Level measuring to the ground



OPTIONS		
Code	PL-PIC	CAB T3
Model	Lightning rod 2 m	Ground cable

KOHLER

RAYWIN

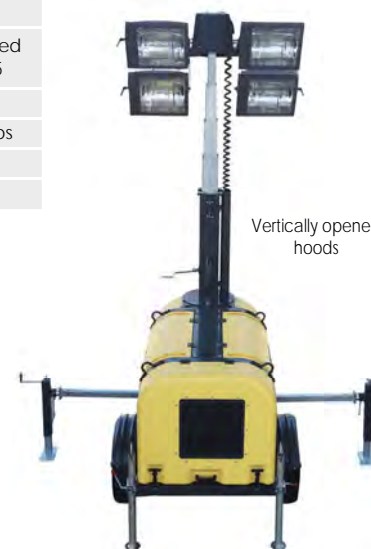

Vertically opened hoods

Adjustable feet in width and position adapting to the ground

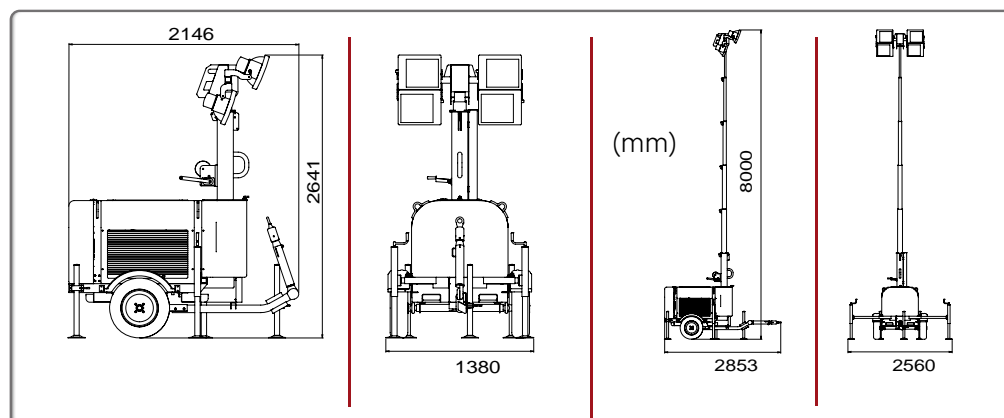

COMPACTON

MOBILE EQUIPMENT

CONCRETE EQUIPMENT

SURFACING

CUTTING - GRINDING

PLUG-IN tower light with rotating mast

The tower light MAXI LIGHT PLUG-IN LED DIALUX is available for diverse rental applications and to supply the users with solid lighting equipment that is easy to transport and meets all site requirements. The additional safety functions ensure that the lamps are protected during transport.

The most flexible and the most powerful lighting solution on the market, allowing the users to connect the tower light to every type of power supply, including an auxiliary supply, a generator and even directly to the network.



PLUG-IN LED

FEATURES AND BENEFITS

- Ideal for special event management, projects in urban areas, temporary roads, public construction and lighting.
- Durable, unbreakable LED lamps: more than 20,000 hours.
- Bright coverage area of 3000m² (20 lux on average).
- Footboard facilitates dismantling.
- Compact.
- Economic.
- Perforated lamp armatures permitting wind to blow through without causing pressure to the mast.
- The 270° degree mast rotation improves the angle and lighting surface.

Code	MAXLIGHT230VSW	MAXHYBRID
Model	MAXI-LIGHT PLUG-IN LED	MAXI-LIGHT PLUG-IN & GO HYBRID
Frequency (Hz)	50/60	50/60
Rated power hp (kW)	(0,64)	3 (2,2)
Winch	Manual	Manual
Height (m)	8	8
Minimum dimension (mm)	1160 × 800 × 2200	1160 × 800 × 2200
Maxi. dimension developed (mm)	1950 × 1250 × 7200	1950 × 1250 × 7200
Net weight (kg)	265	296
Lamp power (W)	160 W × 4	160 W × 4
Lamp type	LED	LED
Lighting area (5 lux min.) (m ²)	3000	3000
Lumen	61000	61000
Outlet socket 16 A - 230 V	Yes	Yes
Trailer	No	No
Programmable Hour Meter Astro clock/timer	Option	Option
Grounding cable	Option	Option
Sound pressure @ 7m (dB)	65	75
Engine	-	PACLITE*
Certified power SAE J 1349		



PLUG-IN & GO HYBRID

*PACLITE ENGINE	
Gasoline engine with manual start	
Power: 3,1 cv (2,5 kw)	
Autonomy: 8 h	
Fuel tank: 10 l	
Sound pressure: 75 (dB)	
OPTION	Code
X-TRAIL For serial connection	TX2

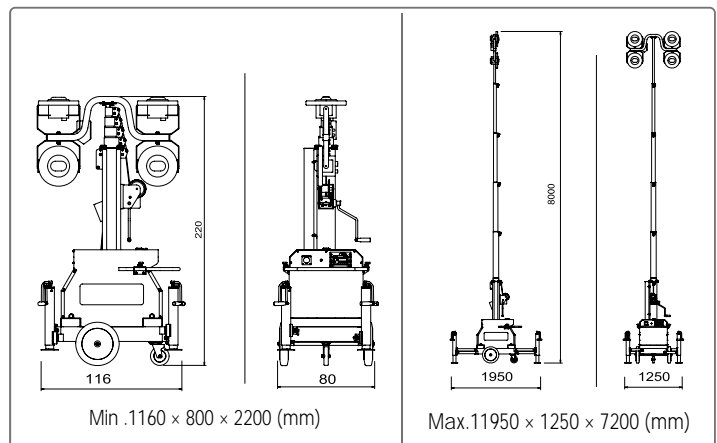
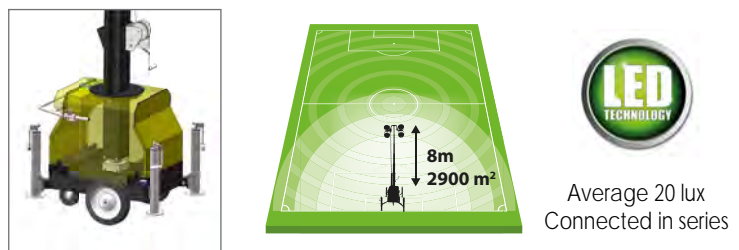

Insulated soil Pick PAC-PIO3.0

Generally, this tool is used by public companies to safely search around pipes /cables without damage.

Perfect for rental.

FEATURES AND BENEFITS

Ideal for unpacking, disintegrating, moving soil types such as earth, gravel, rubble, debris and dust. It also allows the cleaning of construction or agricultural machines.



Code	PIO-3
Model	PAC-PIO3.0
Weight (kg)	3,2
Lenght overall (mm)	1270
Tube length (mm)	1000
Air consumption - small nozzle (cfm)	65
Air consumption - large nozzle (cfm)	105
Recommended working pressure- bar (psi)	6 (87)
Tested working pressure - bar (psi) with 19 mm air hose	7 (101)

Pole scabblers POL-PAC

The POL-PAC is a powerful pole scabblers suitable for bush-hammering vertically and in hard-to-reach places.



POL-PAC M1



POL-PAC M3

Code	PAC-M1	PAC-M3	P/N 123006M
Model	POL-PAC M1	POL-PAC M3	PISTON
Type	Single Head Hand Scabblers	Triple Head Hand Scabblers	Piston 1 unit
Weight (kg)	3,5	4,5	For POL-PAC M1 and POL-PAC M3
Length (mm)	635	635	
Working width (mm)	20	95	
HAWS*	3,8	4,8	

*Triple axis reading in m/s²



Piston

Pneumatic breakers

A pneumatic breaker should be robust and reliable yet easy to use. That's exactly what you get with the PACLITE demolition breakers.

These tools deliver the power and durability that you demand for tough jobs including breaking reinforced concrete, heavy road work, trenching, and cutting tarmac or frozen ground.

PACLITE has taken a proven product and made it even better by making continuous improvements with the operator in mind. The result is a proven design that delivers the performance and durability you need to get the job done.

Products combine a balanced weight with higher impact energy for excellent productivity. These breakers are also easy and comfortable to operate and service.

FEATURES AND BENEFITS

- Ergonomic handles reduce operator exposure to hand-arm vibration.
- Silencer reduces noise level.
- The main components are made of forged steel for maximum durability.
- Built-in oil reservoir.



THREE WEIGHT CLASSES

LIGHT RANGE



PAC-TEC05



PAC-TEC11

MEDIUM RANGE



PAC-TEC21



PAC-TEC24HAV

HEAVY RANGE



PAC-TEC29HAV



PAC-TEC32

DEMOLITION TOOLS

Part No	Tool Type	Steel Type	Shank Size	Tip Size	Length Below Collar
912083	Breaker >20 kg	Moil	1 1/4" (32 mm)	Point	15" (380 mm)
912293	Breaker >20 kg	Chisel	1 1/4" (32 mm)	1 1/4" (32 mm)	15" (380 mm)
912454	Breaker >20 kg	Asphalt	1 1/4" (32 mm)	5' x 6" (125 x 50 mm)	15" (380 mm)
910023	PAC-TEC11	Moil	7/8" x 3,1/4" (22 x 82 mm)	Point	15" (380 mm)
910233	PAC-TEC11	Chisel	7/8" x 3,1/4" (22 x 82 mm)	1" (25mm)	15" (380 mm)
910913	PAC-TEC11	Spade	7/8" x 3,1/4" (22 x 82 mm)	4.3" x 4" (100 x 110 mm)	15" (380 mm)
912011	PAC-TEC05	Moil	3/4" x 2" (19 X 50 mm)	Point	10" (250 mm)
912211	PAC-TEC05	Chisel	3/4" x 2" (19 X 50 mm)	1,2" (30 mm)	10" (250 mm)
912121	PAC-TEC05	Wide Chisel	3/4" x 2" (19 X 50 mm)	4" x 51 (100 x 130 mm)	10" (250 mm)

PAC-TEC - Performance in work

Choose the option that fits your needs. PACLITE breakers are available in different models and sizes in order to suit a variety of applications. There is a choice of several different shanks to cater to needs in different markets. You can also choose from standard or vibration reduced breakers with reliable vibration dampening HAV models. All models comply with the European Union Noise Directive (2000/14/EC) and are CE-marked.

APPLICATIONS

- General demolition.
- Ideal for heavy civil engineering work, demolition, plant hire, utility and municipal work.
- Hard/reinforced concrete.
- For use in soft and medium material.



A RANGE OF SIX MODELS TO FIT ALL TYPES OF WORK

Model	PAC-TEC05	PAC-TEC11	PAC-TEC21	PAC-TEC 24HAV	PAC-TEC 29HAV	PAC-TEC32
BREAKER TYPES	LIGHT		MEDIUM		HEAVY	
Code	TEC05	TEC11	TEC21	TEC24HAV	TEC29HAV	TEC32
Weight kg (lb)	5 kg (11)	10,9 kg (24)	22,9 kg (50)	24,6 kg (54)	29 kg (63)	32,5 kg (71)
Breaker version	Standard	Standard	Standard	Vibration dampened	Vibration dampened	Standard
Shank size mm (in) hexagonal	19 x 50 (3/4)	22 x 82,5 (3,1/4)	32 x 160 (1,1/4) 28 x 160 (1,1/8)	32 x 160 (1,1/4) 28 x 160 (1,1/8)	32 x 160 (1,1/4) 28 x 160 (1,1/8)	32 x 160 (1,1/4) 28 x 160 (1,1/8)
Length mm (inch)	385 (15,75)	510 (20)	625 (25)	700 (27,5)	712 (28)	650 (25,5)
Air consumption l/s ² (cfm)	7 (16)	14 (30)	22,5 (48)	22,5 (48)	26 (54)	30 (65)
Bore mm (inch)	28 (1, 125)	40 (1,57)	57 (2,1/4)	57 (2,1/4)	44 (1,73)	57 (2,2)
Impact rate strokes mm (inch)	61 (2,4)	89 (3,5)	125 (5)	127 (5)	170 (6,7)	146 (5,75)
Frequency/Hz (bpm)	43 (2600)	27 (1620)	21 (1250)	21 (1250)	16 (960)	21 (1250)
Vibration level 3 axes (ISO 28927-10) (m/s ²)	7,05	8,1	6,9	6,4	6,4	8,5
Rec working bar (psi)	6 (90)	6 (90)	6 (90)	6 (90)	6 (90)	6 (90)
Hose fitting bsp	3/4"	3/4"	3/4"	3/4"	3/4"	3/4"
Air hose mm (inch)	19 (3/4)	19 (3/4)	19 (3/4)	19 (3/4)	19 (3/4)	19 (3/4)
Sound level guaranteed, lw(2000/14/ec)* dB (A)	105	108	107	108	108	111
Sound pressure level (ISO 11203)** lp,r=1m dB	TBC	88	103	102	106	107



External oil lubricator
Code : PAC-LUB



COMPACTION

MOBILE EQUIPMENT

CONCRETE EQUIPMENT

SURFACING

CUTTING - GRINDING

Centrifugal Wastewater Pump

PACLITE Centrifugal wastewater pump WP80 has proven its worth on building sites around the world. These self-priming supercharged pumps are able to withstand big particles until 8 mm. It offers a large volume, a high discharge height and consequently a high pumping power. WP80 pump is ideally suited for construction sites requiring rapid dewatering.

FEATURES AND BENEFITS

- Silicone Carbide Mechanical Seal is 4-5 times more durable than standard carbon ceramic mechanical seals.
- Suitable for sandy and muddy water usage.
- Particles up to 8 mm can be pumped through.
- Guaranteed suction head of 8 meters.
- Long bolt assembly for easy maintenance.



Code	WP80
Model	WP80
Diameter (mm)	75
Capacity (L/min)	1000
Suction head (m)	7
Delivery (m)	28
Pump Package Size (mm)	420 x 250 x 250
Weight (kg)	30
Engine	Honda GX160 5,5 Hp
Pump dimension with engine (mm)	530 x 450 x 480

OPTIONS	
PFP80P-SH-10M	Fireman coupling mounted to 10 m flat hose
PFP80P-SH-20M	Fireman coupling mounted to 20 m flat hose
WP80-R6	Suction hose 6 m

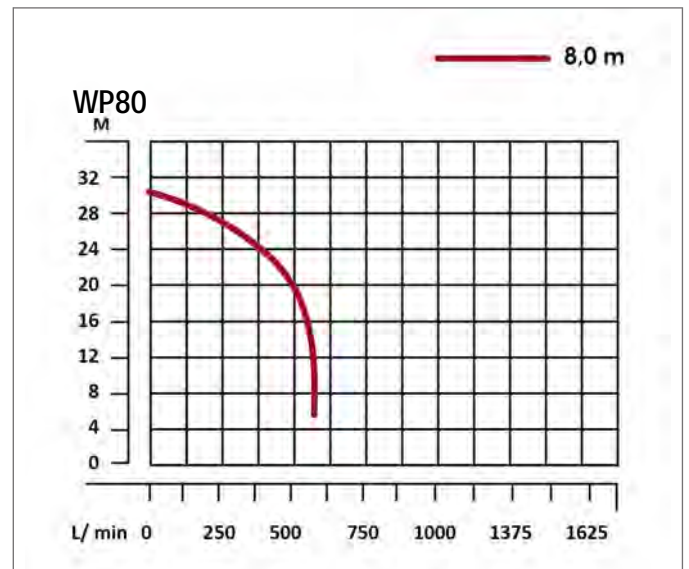

Submersible flexible shaft pump 72 m³/h

Submersible pump for draining and removal of water from trench sand building sites without use of electric power. The FORCE pump can take aggregates as large as 15 mm and offers a more rugged heavy duty design.

FEATURES AND BENEFITS

- Pump with high output and a capacity of 72 m³/h.
- Cast steel impeller.
- Solid size capacity: 15 mm.
- High quality components and strong flexible shaft, 6 m.
- Two-dog coupling identical to FP poker vibrators which enable compatibility and versatility in utilisation between water removal and concreting work.
- Autonomous, portable and lightweight in size, this pump can be used in a multitude of applications.
- Same engine power units used together with FP-37-DC poker vibrators.
- Standard delivery with discharge hose of 10 meters and 3" (75 mm), fireman's quick release coupling.
- Engine Honda GX160.
- 2800 rpm, max. head height 15 m.
- Flexible shaft hose 6 meters long.



norm SAE J1349



POWERED by HONDA



Stainless steel impeller



FP Couplings compatible with PPF-80 pump



PACK VIB 35 mm + PUMP

COMPLETE PUMP	
PPF80-H	Complete pump 6 m with accessories included + fireman couplings + discharge hose 10 m + Motor Honda GX160
PPF80 Diesel	Complete pump 6 m with accessories included + fireman couplings + discharge hose 10 m + motor HATZ diesel 1B20
PPF80-E 230V	Complete pump 6 m with accessories included + fireman couplings + discharge hose 10 m + motor 230 volt-1-50Hz
104.10.00306	Pack pump set complete + flexible shaft poker FP-37-DC
PUMP PPF80-H OPTIONS	
PPF80P-SH-10M	Fireman coupling mounted to 10 m flat hose
PPF80P-SH-20M	Fireman coupling mounted to 20 m flat hose
PPF80-Pompe	Pump only (shaft + strainer) without accessories
PPF80-PUMP	Strainer only : Pump core
PPF80-OIC	Flexible shaft complete 6 m (inner and exterior part with couplings)
PPF80-FLI	Complete inner flexible shaft 6 m
Certified power SAE J 1349	



Force Pump core



Terrain Loader

PACLITE specializes in solutions to service sites, since we always pay attention to the specific requirements of our customers by offering the expertise of our technicians and reliability of the brand PACLITE which boasts experience in its field. Perfect for any type of work and made from high quality components. Useful for eliminating operator fatigue.

Manoeuvrable in tight spaces, quick and agile in movement, strong, robust and compact, but also available and adaptable to your requirements according to the multitude of sectors in which they can be used.

It is also possible to load and transport these loaders on most trucks due to their small size and light weight.

FEATURES AND BENEFITS

- Robust design of the hopper and discharge system, better balanced and more weight compared with other machines on the market.
- The Terrain Loader has a Honda engine of 5,5 Hp.
- It allows larger capacity 345 kg.
- Motorized 4-wheel loader drive that can go anywhere a tracked machine can.
- Perfectly balanced, the operating gear is smooth and easy as driving to empty at full load.
- Easy and fast for high productivity.
- All four tires are identical for easy use on all types of terrain.
- The bucket is changed within seconds with the flat tray; both are always included in the delivery of the machine.
- May climb hills up to 30 degrees.
- USA manufactured gear box Tecumseh.
- It combines well with a number of other types of equipment such as mini-excavators and cement mixers.
- Clutch EC.



Code	HTL350
Model	HTL350
Dimensions L x W x H (mm)	1802 x 721 x 955
Engine	Honda GXV160
Start	Manual
Engine power hp (kW)	5,5 (4)
Max speed (km/h)	5,8
Capacity (l)	137
Capacity (kg)	345
Weight (kg)	162
Vibrations (m/s ²)	4,52
Engine speed (rpm)	2890
Larson Davis HVM test equipment 100 - Tri-axial accelerometer	

POWERED by
HONDA
norm SAE J1349

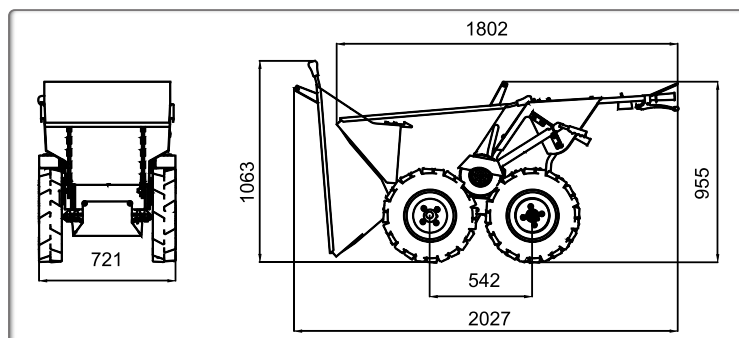

Flat tray always included

500 kg Track driven Power dumper with manual start

The track dumper PACLITE MD500 can operate next to the nearest centimeter on any ground thanks to its compact size and precise handling. Optimized and compact design, ideal for narrow passages through standard doors and portals.

FEATURES AND BENEFITS

- Tracked under carriage with hydraulic mechanical transmission fitted with a modular chassis.
- Controlled by manual levers with 2 gear pumps and fixed displacement orbital engine.
- Steering throughout the rotation of the tracks.
- Double effect cylinder for the frontal lifting of the accessories.
- Rubber tracks realized in monobloc structure with core in iron wire and inserts in treated iron.
- Loading skip with large angle of discharge. The round shaped design gives both to the machine a new styling and allows a quick discharge of the transported materials.
- Two levers connected with the hydraulic distributor to control travelling. Each lever controls independently the movements of each track, enabling the operator to have a complete control in every phase.



Model		MD500		
Drive Train	Clutch	-	Driven Pulley	
	Steering Mechanism	-	Lever	
	Track Width	mm	178	
	Transmission Oil Capacity	litre	12	
	Gearbox Shift Position	-	3F, 1R	
Hydraulic System	Hydraulic Pump	Type	-	Gear Pump
		Max Speed	rpm	3000
		Working Pressure Max	kg/c m ² (psi)	210 (3000)
	Hydraulic Fluid Capacity	litre	8	
	Tipping Cylinder Bore Size	mm	55 x 35	

		Code	MD500H	
		Model	MD500	
Machine Weight		kg	326	
Maximum Payload			500	
Dimensions	A - Overall Length	mm	2032	
	B - Overall Width	mm	785	
	C - Overall Height	mm	1260	
	D - Overall Rubber Track Width	mm	757	
	Bucket Size	(W x L x H) mm	785 X 1251 X 858	
	Ground Clearance	mm	192	
	Step Height	mm	190	
Engine	Model	-	VWM 9.0	GX 270
	Engine Type	-	HONDA	OHV single-cylinder, 4 stroke (8.4HP)
	Displacement	cc	270	
	Compression Ratio	-	8.5 : 1	
	Max Revolutions per minute	rpm	3600	
	Torque	-	19.1 Nm/1.94 kgfm/2500 rpm	
	Fuel Tank Capacity	litre	5.3 liters	
	Fuel Consumption	-	2.4 lt/h @ 3600 rpm	2.5 lt/h @ 3600 rpm
	Performance	Speed	Forward 1	km/h
Forward 2			km/h	3
Forward 3			km/h	5
Reverse			km/h	2

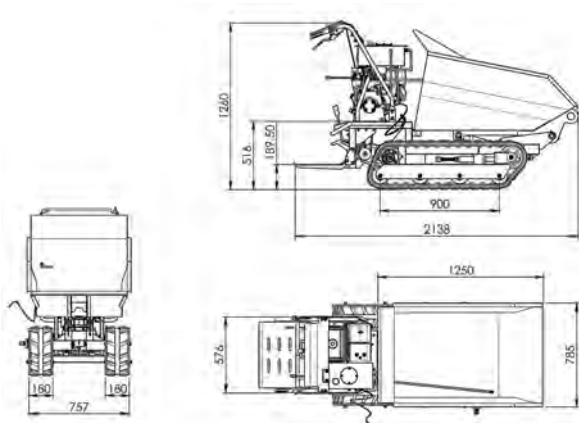

PACLITE generators

Reliable gasoline generators for all power supplies and wherever no electrical network is available. The engine-generator combination is installed on rubber pads in a solid steel frame equipped with wheels and handles.

FEATURES AND BENEFITS

- Robust and safe.
- Honda 4 Stage engine.
- Strong frame.
- Transport wheels and carrying handle included.
- Unique model PACLITE.
- Linz alternator.
- Made in EU.
- 2 outlets 230 V.



POWERED by
HONDA
norm SAE J1349



Code	PAC-GEN 4D	PAC-GEN 4	PAC-GEN 5	PAC-GEN 8	PAC-GEN 8T
Model	PAC-GEN4000D	PAC-GEN 4200	PAC- GEN 5000	PAC-GEN8000	PAC-GEN8000T
Engine	YANMAR LN 70	HONDA GX160	HONDA GX270	HONDA GX390	HONDA GX390
Power (KVA - W - V)	5 - 4,200 - 230	4,2 - 3000 - 230	5 - 4100 - 230	8 - 6400 - 230	8 - 6400 - 400
Dimensions (mm)	460 X 730 X 660	650 x 600 x 560	760 x 730 x 660	830 x 730 x 660	830 x 730 x 660
Output / Voltage V (A)	2 x 230-1 (16)	2 x 230-1 (16)	2 x 230-1 (16)	1 x 230-1 (16A) & 1 x 400-3 (16)	2 x 400-3 (16)
Weight (kg)	108-80	47	63	79	83
Sound level @ 7 m (LwA - LpA)	80	96-73	97-74	96-73	96-73
Certified power SAE J 1349					

Generators on request up to 200 KW





The largest selection of machines - No. 1 worldwide vibration equipment

PORTABLE VIBRATORS

MULTIVIB



Basic

CONVERTERS

BOXTECH2

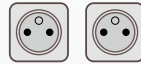

230 V

BOXTECH3

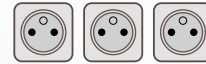

230 V

FUZ13



230 V

VX BOOSTER & VX PREMIUM



High frequency pokers for external converters

FUZ30 & FUZ30-Cart

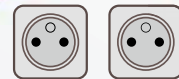

230 V & 400 V

SYNCHROMASTER

High frequency pokers with built-in inverter



SYNCHROMASTER ERGOTRONIC

Advanced



FUZ80



400 V

VP

Pneumatic pokers



FP

Mechanical pokers FP



PORTAVIB, EVIB & ECO-VIB

Innovative concrete vibrators



FUZ45D



AF22



230 & 240 V Electric

Battery powered concrete vibrator

E-VIB impresses with its flexibility and efficiency.

Zero emissions, no cables, it is simple to use and load the removable batteries. Flexible shaft and ergonomic handle are perfect for vibrating concrete wet floors.

The vibrators are equipped with a quick coupling for simple and fast handling, as well as mobile and easily portable.

The vibrating heads are induction hardened and therefore offer a high resistance to wear.

FEATURES AND BENEFITS

- Easy maintenance: reduced costs and time for both work and no maintenance.
- Durable components: hardened vibrating head, solid case, reinforced protection hose, ideal in rental use.
- Reliable and solid performance: highly efficient electric motor for productive work, providing excellent result.
- Stable and fast recharge of batteries.
- Vibration box contains 2 batteries.
- Shock resistant plastic case.
- Battery charger for both : 110/230 volts & 50/60Hz.
- 30 mm Diameter.
- Induction hardened vibration head guarantees high wear resistance.
- No specific tools required to replace the vibration head.

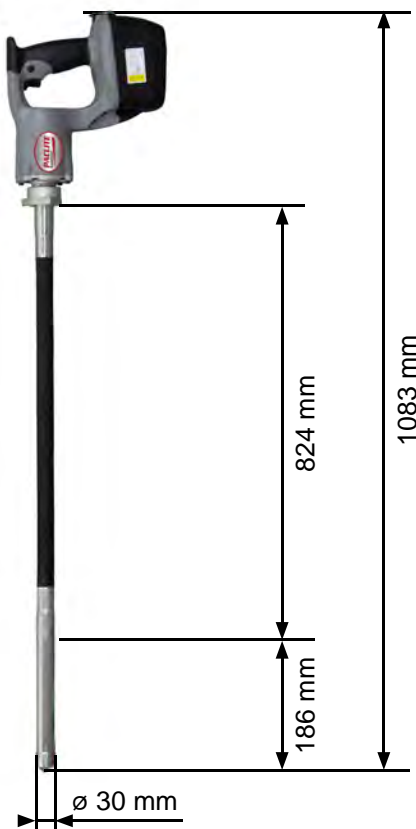

Low hand-arm vibration handle

Code	E-30 ECO
Model	E-VIB x 0.6M
Type	Flexible
Voltage	DC18V- 4,0Ah 42 V 3-200 Hz
Frequency (Hz)	200
Dimensions L x W x h (mm)	1083 x 93 x 250
Head dimensions D x L (mm)	30 x 186
Weight (kg)	4,2
Total weight (kg)	9,4
Sound pressure (dB (A))	74

Battery	E-30-18V
Chemical composition	Li-Ion battery
Battery capacity (Ah)	4
Average charging time (min)	50-60
Supplied batteries	x 2 - 18 Volt Li-ion
Compatible batteries	BL1830, BL1840
Net weight EPTA (kg)	3
Hand-arm vibrations on 3 axes (m/s ²)	3,6

* Measured according to ISO 5349



280-300 mm

The influence of Zone is determined by the diameter of vibrator head.



STANDARD ACCESSORIES

Transport case + 2 batteries
+ 1 battery charger



x 2 batteries B1840

Battery charger C1860L



ECO-VIB

Cordless high frequency concrete vibrator with battery



Eco-friendly high frequency concrete vibrator

The market's first high-frequency concrete vibrator ECO-VIB is a compact, cost-efficient piece of equipment that replaces existing technology. ECO-VIB is cordless eliminating the need for any protruding cables as well as reducing the number of workers needed when casting the concrete.

ECO-VIB offers three different sizes and a quick connecting operating handle. The unit is the perfect alternative for the vibration of floors.

Advanced technology and sealed case allow for zero emission and zero maintenance. The unit does not require an integrated converter and includes a 230-240V fast charger.

This is a powerful piece of equipment that is also reliable and safe on the job site. It is flexible, ergonomic and easy to use. Additionally, thanks to its size and weight, it is easy to move around the job site while in use. The carrying strap and operator handle are included.

FEATURES AND BENEFITS

- Delivered as a full set - includes one vibrator, one battery, and fast charger (optional extra battery upon request).
- Powerful, extremely durable and features a completely tempered vibrator head.
- Lightweight.
- Ergonomic.
- No pollution, eco-friendly and zero maintenance.
- Easily replace parts yourself.



COMPACTION

MOBILE EQUIPMENT

CONCRETE EQUIPMENT

SURFACING

CUTTING - GRINDING

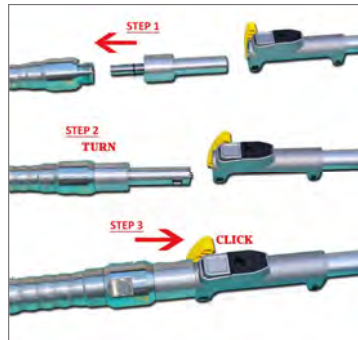

Packed following the directive MSBFS 2016:8



Low hand-arm vibration handle

Code	ECO38	ECO49
Model	ECO 38	ECO 49
Poker + 1 Battery + charger + transport box		
Tube size (mm)	38	49
Assembled total length (cm)	205	208
Tube length (mm)	330	410
Vibration capacity (m ³ /hr)	25	28
Vibration in concrete (rpm)	12000	12000
Centrifugal force (N)	4100	5200
Vibration value (m/sec ²)	3,45	3,63
Total weight (kg)	12	13
Amplitude (mm)	2,8	3,1
IP	67	67
Sound level dB (A)	75	75

BATTERY	56V7 (A)
Type rechargeable	Li-Ion
Charging time (min)	50
Working battery capacity (min)	75
Voltage (V)	220-240
Watt (W)	500
Output (V) @ 5-8 (A)	56
No. of supplied battery	1
Amperage (A)	5

OPTION INDIVIDUAL ACCESSORIES	M38	M49
Flexible shaft Ø (mm)	38	48
Battery	Li-Ion	Li-Ion



Battery 5 (A) 70 min

Hand held portable poker vibrator

Exceptionally good for the rental industry.

Assembled in two parts; a small Honda engine, throttle with adjustable speed that connects to a flexible shaft and eccentric movement providing high performance and capacity of concrete. Small and light, this unit is exceptionally easy, providing powerful vibration to move around without causing operator fatigue.

FEATURES AND BENEFITS

- Portable poker vibrator, easy to operate, light-weight with carry on strap.
- Suitable for floors, form works, house slabs.
- Connected to a shaft of 38 or 45 mm.
- Easy to transport.
- Compatible universal quick coupling.



Code	Porta-38H	Porta-45H
Model	Portavib	Portavib45
Flexible shaft length (mm)	545	545
Vibrator diameter (mm)	38	45
Frequency Hz (rpm)	150 (9000)	150 (9000)
Amplitude (in air) (mm)	2,8	2,8
Engine model	Honda GX35 4 stroke	Honda GX35 4 stroke
Motor power hp (kW)	1,6 (1,2)	1,6 (1,2)
Weight (kg)	10,5	10,5
Certified power SAE J 1349		

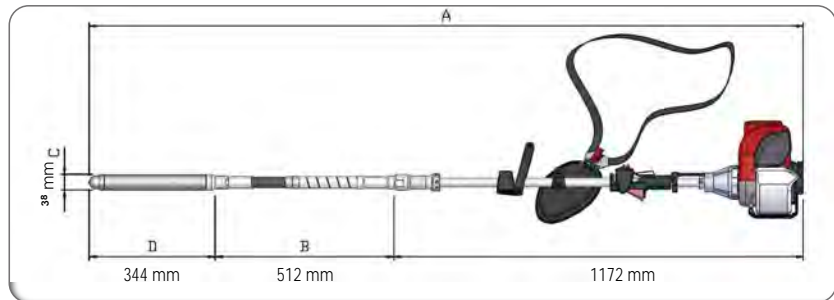

High frequency hand-held poker vibrator

The Multivib Vibrator produces a most flexible and economic solution. The interchangeable head produces the highest possible amplitude. Energy is transferred from the compactly designed motor, via the flexible shaft made out of high quality carbon steel wire. The outer casing is made of abrasive neoprene rubber, that gives both flexibility and resistance to wear.

The Multivib design can take both standard shafts as well as a new rotashaft, which makes it possible to position the motor on the ground and twist the shaft into many working positions, making it particularly useful when working on first floor castings and repair jobs.

The Multivib feature offers a lighter weight motor without losing any power and is mounted directly into the carbon casing.

FEATURES AND BENEFITS

- On-site vibration of concrete for foundations, walls, columns, and slab work. In-plant vibration of concrete during the production of pipes, slabs, beams, double T's, columns, and walls.
- Powerful, double insulated MOTOR.
- Interchangeable heads with double bearings.
- Integrated filter.
- Easy to change carbon brush kit - no tool needed.
- Rotashaft connections offer ergonomoy and comfort in many working positions.



Multivib/standard and rotashaft connections

Multipac: complete & mounted = only in Ø 36 mm (flexible motor 3 m Ø 36 mm)

Model	Code
Multipac: complete & mounted ø 36 mm	Multipac3
Multivib motor universal	
CE - plug 2 pin -230 V	pacli 10.273
Plug cetac yellow UK/EIRE-115 V	pacli 10.272
Plug UL USA -115 V	pacli 10.274
Multivib poker head for flexible shaft	
Poker head ø 26 mm	pacli 22.432
Poker head ø 36 mm	pacli 22.433
Poker head ø 42 mm	pacli 22.434
Poker head ø 50 mm	pacli 22.435
Poker head ø 57 mm	pacli 22.436
Flexible shaft length	
Multiflex 2 l - 2 m	pacli 22.437
Multiflex 3 l - 3 m	pacli 22.438
Multiflex 4 l - 4 m	pacli 22.439
Multiflex 5 l - 5 m	pacli 22.478
Multiflex 6 l - 6 m	pacli 22.500

MULTIVIB Model	230V	115V	Multipac
Motor	Universal single phase electric		
Rated Power kW (hp)	2,3 (3)		
Input current (A)	6/10		
Frequency (Hz)	50/60		
Rotation speed (tr/min)	16 000		
Dimensions (mm)	320 x 130 x 220		
Protection	IP44		
Weight (kg)	5,7		
Insulation Class	Double insulation		
Cord - Plug (mm²)	H07RN-F 2 x 1,5		
Flexible - Connection diameters available (mm)	26 - 36 - 42 - 50 - 57	36	
Multiflex length (m)	2 - 3 - 4 - 5 - 6	3	
Manufacture standards : EN 60745-2-12:2003 EN 60745-1:2003			
Certified power SAE J 1349			



Flexible Shaft MULTIFLEX					
Model	Ø26	Ø36	Ø42	Ø50	Ø57
R.P.M.	10 000				
Compaction Ø (cm)	20	25	70	90	95
Performance (m³/h)	8	10	20	29	35
Vibration Force (N)	1000	1500	3000	4500	6200
Manufacture Standards	EN 12100-1:2004, EN 12100-2:2004, D 89/392/CEE				

Converters

More powerful and durable, rugged design, easy to use and low maintenance, this equipment allows for long-term operations in the harshest conditions. Tried and tested in extreme conditions, these converters are able to withstand dust, water and high temperatures without compromising the performance. These compact machines are powerful, easy to use and reliable because of their simple design. The new series of converters consists of four models to meet the needs of high-frequency vibrators. The insulation class of these four models is Class (H) leaving extra power margin.

FEATURES AND BENEFITS

- Thermal protection in the switch prevents unnecessary damage if the converter is incorrectly used or exposed to much stress.
- **BOXTECH 2 / BOXTECH 3** are large capacity electronic converters for 2 or 3 poker vibrators.
- **FUZ13, FUZ30 and FUZ80** have increased capacity, reduction in cost and they have two or 4 outlets, single phase 230 volt or three phase 400 volts.
- **FUZ45D** is a generator running at 42 volts. It allows three poker vibrators (42 volts) working at the same time.
- Protective steel frame and transport wheels.

FUZ13



FUZ30

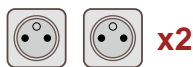

FUZ 30-CART



FUZ80



FUZ45D

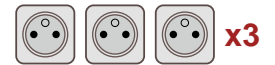

*60Hz Upon demand	Code	BOX2	BOX3	FUZ13	FUZ30	FUZ80	FUZ45DL
	Model	BOXTECH2	BOXTECH3	FUZ13	FUZ30	FUZ80	FUZ 45D DIESEL
	Supply Input (V)-Phase	230	230	230	230	400	Diesel
	No. Of Output Sockets	2	3	1	2	4	3
	Output Current (A)	32	34	14	26	80	45
	Dimensions W x H x L (mm)	425 x 220 x 350	560 x 300 x 350	410 x 400 x 240	550 x 330 x 370	550 x 330 x 370	790 x 500 x 860
	Weight (kg)	17	21	23	32	54	60
	Connection engine frequency* (Hz)	50/60	50/60	50	50*	50*	50*
	Generator output frequency (Hz)	200	200	200	200	200	200
	Generator output voltage (V)	42	42	42	42	42	42
	Degree protection motor-generator	IP57	IP57	IP 44	IP 44	IP 44	IP44
	Nominal generator power (kVa)	2,70 (2)	4,0 (3)	1,6 (1,2)	2,70 (2)	8,45 (6,5)	4,1 (3)

NEW !

BOXTECH2



BOXTECH3



Electronic converter with variator

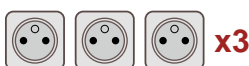

Connection setting quick guide HF CONVERTER /HF POKER

Model	OUTLETS					
	BOXTECH2	BOXTECH3	FUZ13	FUZ30	FUZ80	FUZ45D
VX 40 Premium	2	3	1	2	4	3
VX 45 Premium	2	3	1	2	4	3
VX Booster 52	2	3	1	2	4	3
VX Booster 58	2	3	1	2	4	3
VX Booster 65	2	2	1	2	4	3
VX Booster 75	2	2	0	2	4	2
VX 40 D	2	3	1	2	4	2
VX 50 D	2	3	1	2	4	3

STANDARDS AND DIRECTIVES

Machinery Directive	98/37/EC replaced by 2006/42/EC
Harmonized standards	EN292 replaced by EN/ISO 12100-1/2
Standard	UNE-EN-ISO 9001:2015 Certificate N°: 1895/20 RoHS Compliant 2011/65UE
Low volt directives LVD	73/23/EEC replaced by 2006/95/EC
Noise Emission Directive	2000/14/EC replaced by 2005/88/EC
Electric magnetic compatibility	89/336/EEC replaced by 2004/108/EC



BOOSTER - the ultimate high frequency concrete vibrator

This vibrator is equipped with heavy excentric weights to perform with more power and in particular, more amplitude.

VX PREMIUM - High Frequency poker vibrators

VX BOOSTER - The ultimate performing vibrator for all type of concrete mixes. Standard length for floor castings with comfortable handle.



FEATURES AND BENEFITS

- Long-life design: The vibration-proof windings are embedded in synthetic material. They will withstand a short-term load of up to 180 °C (356° F). The heavy-duty roller bearings are grease-lubricated for high performance.
- Overload protection: The thermal circuit breakers prevent the motor from being damaged due to overheating.
- Easy maintenance. The vibrator head can be replaced without the need for special tools.
- Low amperage on VX pokers.
- Ergonomic switch with 10 meters of synthetic abrasive resistant cable, 5 m of abrasive resistant hose to the poker, and synthetic abrasive resistant electric cable.
- Stretchable hydraulic hose.
- Can be used with most 42 V, 200 Hz, 3-phase supplies.
- The input cables are sealed in order to prevent water from entering the poker.
- The cable is flexible, multi-wired, cold-resistant and durable.



PACLITE No. 1 in Concrete Vibration

Code	10000	100001	10257	10258	10259	10260	10336	10359
Model	VX40 Premium	VX45 Premium	VX Booster 52	VX Booster 58	VX Booster 65	VX Booster 75	VX40D ERGO	VX50D ERGO
Tube diameter (mm)	38	42	52	58	65	75	42	52
Voltage (V)-Hz 3x42	42V-3-200 Hz							
42 V power charge (W)	465	490	800	900	980	1250	875	800
Length of tube (mm)	280	320	382	410	425	430	280	382
Hose Length (m)	5	5	5	5	5	5	0,85	0,85
Cable length (m)	10	10	10	10	10	10	15	15
Tube weight (kg)	1,8	2,7	4,8	6,4	8,2	10,8	2,7	4,8
Total weight (kg)	9,4	11,5	13,6	14,6	18,3	20,7	8,7	10,4
Capacity vibration m ³ /h	15	20	40	45	50	55	20	40
Frequency in concrete (pmt)	12000	12000	12000	12000	11500	11300	12000	12000
Amps at 42 V loaded (A)	5.0	5	10	11	13	14	5	12
Vibration type	Excentric						Excentric	
Centrifugal force (N)	1390	2155	3900	5585	7275	8460	1390	3900
Amplitude (mm)	1,77	1,83	1,65	1,85	1,85	1,65	1,77	1,65
Vibration (m/s ²)	0,8	0,8	1,9	2,1	3,2	3,8	0,8	1,9
Sound pressure level dB (A)	75	76	79	79	79	79	75	79
Protection class (IP)	IP44/IP57							

Manufactured under standards: EN 60745-2-12:2003 EN 60745-1:2003



VX (D) version
(Ergonomic handle for floors)



PACLITE improves quality components and tests them to the limits. ERP insulated polyurethane sheathed flex cable * Top Flex*



OPTIONS: Special length of 8 or 10 meters operational hose available upon request.

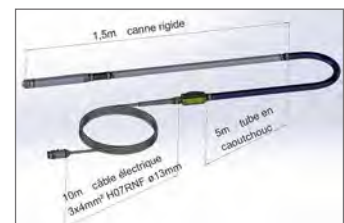

COMPACTION

MOBILE EQUIPMENT

CONCRETE EQUIPMENT

SURFACING

CUTTING - GRINDING

High frequency pokers with built-in inverter

The PACLITE poker vibrator Synchromaster is provided with a built-in converter in the switch box that converts the frequency 50 Hz to 200 Hz, and 1-phase 230 V to 3-phase 210 V which runs the 3-phase motor in the poker. As the poker vibrator is connected to a 1-phase wall socket-outlet it can be used everywhere.

The comfortable start/stop knobs on the front side of the switch box are easily reached. The converter in the switch box has built-in functions that protect the equipment and the user against operational hazards. The strong and user-friendly switch box of impact resistant aluminium is designed to withstand the tough construction environment.

FEATURES AND BENEFITS

- Moulded electronics.
- Strong design.
- Plug-in and work on single phase current.
- Available in 230 V/50 Hz single phase or 115 V/60 Hz single phase in option.
- Also available from 40 mm and 65 to 75 mm on request.
- Thermal protection.
- Overload protection.
- Power loss protection.
- Stretch-proof hose and cable.
- Options: 9 m operative hose available upon demand.

Synchromaster with moulded electronic box IP67 class and Rico electronics used by the US Army



Code	PACLI10.158	PACLI10.159	PACLI10.160	PACLI10.424	PACLI10.400S	PACLI10.402S	PACLI10.403S	PACLI10.450	PACLI10.451	PACLI10.452
Type	SYNCHROMASTER 7 METERS				SYNCHROMASTER S 5 METERS			ERGOTRONIC 1 METER		
Model	Synchro. 45	Synchro. 51	Synchro. 58	Synchro. 65	Synchro. S-38	Synchro. S-51	Synchro. S-58	Ergotronic D-40	Ergotronic D-45	Ergotronic D-51
Tube diameter (mm)	42	52	58	65	38	52	58	38	42	51
Supply voltage, V (+/-10 Hz)	110 V-230 V (50/60)									
Power (kW)	1,5	1,5	1,5	2,2	1,1	1,1	1,1	1,5	1,5	1,5
Length of tube (mm)	320	350	410	425	340	350	410	340	320	350
Hose Length (m)	7	7	7	7	5	5	5	0,7	0,7	0,7
Cable Length (m)	15	15	15	15	15	15	15	15	15	15
Tube weight (kg)	2,7	4,3	6,3	8,2	2,2	4,3	6,3	2,2	2,7	4,3
Total weight (kg)	15	17	19	21	9	14	15	10	11	12
Capacity vibration (m ³ /h)	25	40	45	50	20	40	45	20	25	40
Frequency in concrete (pmt)	12000									
Amps (A)	1,8	2,6	3	3,4	1,3	2,6	3	1,3	1,8	2,6
Vibrator type	Excentric									
Centrifugal force (N)	1900	3750	5750	7200	1750	3750	5750	1750	1900	5750
Amplitude (mm)	2,1	2,8	2,1	2,5	1,9	2,8	2,1	1,9	2,1	2,1
Vibration value (m/s ²)	1,6	2,2	2,5	2,9	1,5	2,2	2,5	1,5	1,6	2,2
Sound level dB (A)	87									
IP	IP 44 - 57									

Flexible shaft pokers

The PACLITE FP poker vibrators with flexible shaft are built on the pendulum principle. This series includes 5 sizes ranging from 25 to 62 mm (1 to 3 in), featuring both high frequency and amplitude, which ensure the very best results in all types of concrete.

Compatible with the pump drive unit.



Universal couplings

FEATURES AND BENEFITS

- Induction hardened magnesium steel alloy.
- Strengthened steel hose reinforced by six layers of special spun steel.
- High vibrating power.
- Long working life, wear resistance and reliability.
- Easy operation and compatibility.
- No special maintenance needed.
- The FP series, ranging from 25 mm of diameter to 62 mm.
- Feature both high frequency and amplitude to ensure the best results in all types of concrete. Principle: a unique balanced single-piece rotating pendulum generating vibration at 12000 rpm. The contractors can rely on their long working life thanks to high-quality components and production process.

Code	FP27DC	FP37DC	FP47DC	FP56DC	FP62DC
Model	FP27	FP35	FP45	FP57	FP62
Tube diameter (mm)	25	35	45	55	62
Hose Length (mm)	334	390	440	465	480
Total weight (kg)	10	18	22	24	25
Length of the flexible shaft (m)	6	6	6	6	6
Amplitude (mm)	0,8	1,3	1,5	1,6	1,7
Frequency in concrete (pmt)	12000	12000	11200	10500	10500
Centrifugal force (N)	570	2000	3800	4300	4300
Capacity vibration (m ³ /h)	8	11	18	24	30
Sound level dB (A)	69	68	73	75,8	75,8
Vibration (m/s ²)	2,46	1,56	3,52	2,66	2,66

Code	AF22-50Hz	AF22-60HZ
Model	AF22-50Hz	AF22-60HZ
Power supply Phase (V)	230	230
Number of output sockets	1	1
Output Voltage (A)	10	10
Dimensions W x H x L (mm)	55 x 25 x 365	55 x 25 x 365
Weight (kg)	18,7	18,7
Engine Frequency (Hz)	50	60
Output frequency (Hz)	50	60
Output Voltage (V)	230	230
Protection class motor/generator	IP44	IP44
Rated Power (kVA)	1,5	1,5

DRIVE MOTORS				
Code	DRCKD-225	DRCHATZ	DRCGX160	DRCEY20-3C
Engine	KOLHER	HATZ 1B20-V5 Diesel	Honda GX160 Gasoline	EY20-3C Robin (no CE)
Net power hp (kW)	4,8 (3,5)	4 (3)	4,8 (3,6)	5,5 (4)
Dimensions W x H x L (mm)	460 x 630 x 520	430 x 630 x 500	420 x 520 x 445	420 x 520 x 445
Weight (kg)	42	42	26	26
Certified power SAE J 1349				



EY20-3C ROBIN



Electric single phase drive unit



Pneumatic pokers vibrator

PACLITE range of pneumatic pokers includes height models with diameters from 26 mm to 108 mm.

They are suitable for use in all types of concrete and a wide variety of construction sites from small foundations to very large commercial construction projects including dams. Vibration parameters have been optimized, thus leading to a maximum output.

FEATURES AND BENEFITS

- Heavy duty single piece rotor.
- High amplitude under full load with a very constant frequency.
- The poker head and the rotor are made of high quality steel.
- All PACLITE VP vibrators include in-line oiler, providing permanent lubrication.
- Option: 4m, 6m or 9m cable.



Interchangeable bronze couplings



Code	103.27.00001	103.37.00002	103.47.00003	103.57.00004	103.67.00005	103.77.00006	103.87.00007	103.10.00008
Model	VP25	VP35	VP45	VP55	VP65	VP75	VP85	VP105
Tube diameter (mm)	26	36	47	56	67	77	87	108
Hose length (m)	4	4	4	4	4	4	4	4
Air consumption (m ³ /min)	0,36	0,46	0,7	1	1	1,3	1,6	1,9
Tube length (mm)	254	267	316	344	365	398	410	415
Tube weight (kg)	1,8	1,5	2,8	4,5	7,9	8,9	9,7	17,7
Total weight (kg)	5	5	7	10	11	17	18	23
Frequency in concrete (vpm)	12000	12000	12000	12000	12000	12000	12000	10500
Frequency in air (vpm)	21000	19000	18000	18000	17500	16000	15900	15000
Centrifugal force (N)	850	1960	3800	6600	11300	14600	22400	24200
Amplitude (mm)	0,5	0,6	0,6	0,8	0,9	1,2	1,8	1,9
Vibration value (m/s ²)	0,51	1,02	2,39	2,87	2,1	2,38	1,95	2,91
Noise level dB(A)	84,5	89,2	95,8	95	94	98	94	96,3

Mechanical trowels and accessories, the best in the industry

M900 / M900-ECO

PRT168

M600 SUPERIOR / M600 E230V

POWERED by
HONDA
norm SAE J1349



M700

Surface Grinder

CUB GRINDER

PAC-GRIND400 / PAC-GRIND500

SPM



Surface Screed

SUPERSCREED

VVL200

VVL-E 230V

POWERED by
HONDA
norm SAE J1349



Hand Tools



Edging Trowels

Uni-Corp is the world largest manufacturer of trowels. The special edging trowel M600 Superior enable the operator to finish tight to the wall without marking or marring, permitting fast maneuvers around obstacles. Patented ABS plastic rotating ring resists concrete build, easy to remove. The perfect rental machine with an innovative spring folding arm.

PACLITE IS THE WORLD'S N° 1 MANUFACTURER OF MECHANICAL TROWELS

NEW !
The rotating ring made of ABS material POLYLAC® PA-747 finish tight to the wall without marking or marring, ring resists concrete build-up.



M600E-230V



M700

FEATURES AND BENEFITS

M600

- Perfectly balanced, fast efficient in use.
- Rotating guard ring of General ABS POLYLAC® material (Characteristics PA-747).
- Heat treated trowel steel – for maximum wear resistance and long life.
- Greater torsional strength – increases machine stability and produces a smoother, flatter finish.
- Delivered with wide finishing blades and edging disc.

M700

- Offers optimized balance.
- This trowel is a true workhorse.
- With a width of 760 mm the rotating guard ring easily fits through most doorways and offers perfect results on a variety of surfaces every time.
- Pan & blades included.



POWERED by HONDA norm SAE J1349



Large lifting eye



Innovative spring folding arm

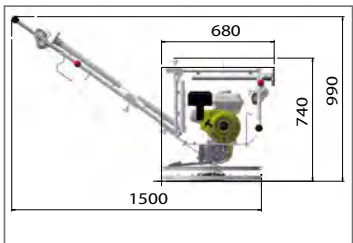

Code	M600NH	M600BP-NH	M600EP-NH	M700H160
Model	M600NH Superior Honda GX160	M600BP ECO-POWER Battery-powered	M600E-230V Electric	M700 Honda Honda GX160
Operating weight (kg)	56	57	62	70
Dimensions straight (mm)	1650 x 630 x 1100	1650 x 630 x 1100	1650 x 630 x 1100	1950 x 700 x 700
Rotor diameter (mm)	600	600	600	700
Blade speed (rpm)	50 -130	75 - Constant	50 -130	50 -130
Number of blades	4	4	4	4
Blade pitch max angle (°)	14	14	14	14
Engine	Honda GX160	PACLITE 82 Volts	ABB 230 V	Honda GX160
Net power hp (kW)	4,8 (3,6)	2,8 (2,1)	1,87 (1,4)	4,8 (3,6)
Rated engine speed (rpm)	3600	1500	1500	3600
Fuel tank capacity (L)	3,1	Battery 8.0 Ah. 82 V 360 Wh	-	3,1
Engine oil capacity (L)	0,6	-	-	0,6
Fuel consumption at rated power (L/h - rpm)	1 - 3600	-	-	1,4 - 3600
Working time with 2 batteries 80% (min)	-	Li - Ion 55	-	-
Hand-arm vibrations according to ISO 5349 on fresh concrete (m/s²)	2,9	2,4	2,4	3,2
Guaranteed sound-power level, LWA dB (A)	98	74	76	98
Sound pressure level (at operator's ear) dB (A)	84	65	66	84
Options	Smoothing Pan	Smoothing Pan TOL700-070703P Battery	Smoothing Pan	Smoothing Pan
Code	TOL606-040803P	82V	TOL700-070703P	TOL700-070703P

Certified power SAE J 1349

M900/Lightweight and foldable handle
M1200 Heavy-duty and foldable handle

The Series Master 900 & Master 1200 incorporates amazing balance, improved serviceability, and your choice of wide or narrow frame, straight or foldable handle providing contractors with the ideal machine for residential and general construction work. The large Master 1200 is designed for high speed burnishing up to 180 rpm with a HD gearbox and PACLITE patented drive system.

PACLITE "Get a grip on the best". Our new Anti-Vibration handle design dramatically reduces the vibration transmitted to the operator. These height-adjustable handles will increase operator comfort and decrease fatigue over an eight-hour day.

FEATURES AND BENEFITS

- The handle is of an ergonomically sound design with all operating controls easily accessible for the operator from the driving position.
- The handlebar acts as a "dead man's grip" safety device and can be reached from any gripping position on the handle.
- The speed selection is made with a switch on the handle.
- The change of the blade angle is made with a circular adjuster on the handle. The blades are reversible for double life.
- The trowel is equipped with two carrying handles for manual raising.
- M900 and M1200 are equipped with chromed frame.
- New detachable transport wheel kit.



POWERED by **HONDA**
norm SAE J1349

M900



M900 CC



Foldable and compact model



Throttle



Security switch



Transport Wheels Models 900

PPT WHEELS 900



The PACLITE gearboxes are the most reliable in the industry for years of maintenance free operation.

Code	M900-CC	M900 Manual	M900EP	M1200-CC
Model	M900 CC Honda	M900 MANUAL	M900-EP230V	M1200 CC Honda
Operating weight (kg)	75	75	75	113
Dimensions Folded (mm)	1305 x 992	1305 x 992	1305 x 992	1408 x 1200
Dimensions W x H x L (mm)	2013 x 992 x 781	2013 x 992 x 781	2013 x 992 x 781	2130 x 1206 x 1008
Trowelling diameter (mm)	925	925	925	1170
Number of blades	4	4	4	4
Trowelling speed (rpm)	65-131	65-131	65-131	65-131
Engine Model	Honda GX200	Honda GX200	-	Honda GX270
Net power hp (kW)	5,8 (4,3)	5,8 (4,3)	4,8 (3,6)	8,4 (6,3)
Rated engine speed (rpm)	3600	3600	1500	3600
Fuel tank capacity (L)	3,1	3,1	-	5,3
Engine oil capacity (L)	0,6	0,6	-	1,1
Fuel consumption at rated power (L/h - rpm)	1,4 - 3600	1,4 - 3600	-	2,4 - 3600
Hand-arm vibration according to ISO 5349 on fresh concrete (m/s ²)	3,8	3,8	3,1	4,1
Guaranteed sound-power level, LWA dB (A)	95	95	75	99
Sound pressure level (at operator's ear) dB (A)	84	84	69	90
Consumption (l/h)	1	1	-	1,8
Shaft	Foldable	Straight	Foldable	Foldable
Dead man's safety Handle	Yes	Yes	Yes	Yes
Clutch	Centrifugal	Manual with Dead man's safety Handle	Manual with Dead man's safety Handle	Centrifugal

Certified power SAE J 1349

Zero CO2 emission trowel powered by battery

PACLITE always one step ahead: the green "e" of the zero emission line not only stands for the drive, but also for a completely emissions-free way of working.

Our zero emission series does not make any compromises.

The Series Master M900-E incorporates amazing balance, improved serviceability, zero emission Master 900-ECO is designed for high speed burnishing max up to 145RPM with a HD gearbox and **PACLITE patented drive system**.

FEATURES AND BENEFITS

- Equivalent performance to conventional machines.
- Significantly lower total cost of ownership and virtually maintenance-free electric motors.
- Ideal for sensitive areas such as interior spaces or inner-city construction sites with emission restrictions.
- Comprehensive user and environmental protection by operating without exhaust gases. Also perfect for in-house work.
- Eliminate noise.



Code	ECO-900B
Model	M900-ECO
Fold handle	Yes
Battery Litium ION (A)	60 V - 40 (A) H
Battery charger	71,4 V - 25 (A) H
Charging time -full charge (h)	1,5
No. batteries	2
Running with pan (min)	45
Running with finishing blades (min)	70
Epoxy color	Yellow
Cooling fan	XQF8038
Running stepless (rpm)	0 to 140
Guaranteed sound-power level, LWA dB (A)	45
Sound pressure level (at operator's ear) dB (A)	35
Dimensions Folded (mm)	1305 x 992
Dimensions W x H x L (mm)	992 x 781 x 2013
Hand-arm vibration according to ISO 5349 on fresh concrete (m/s ²)	2,1
Weight (kg)	109

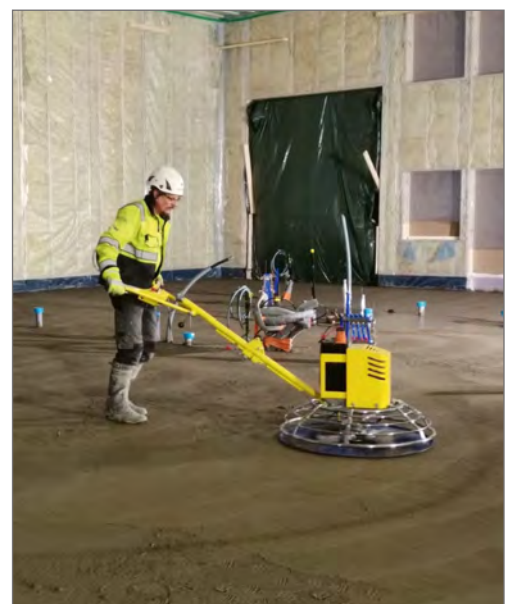

Mechanical ride-on trowel

The Mechanical PRT168 ride-on trowel is equipped with high-horsepower gasoline engine, heavy-duty drive trains and packed in easy to-service frames.

Our heavy-duty gear box and four-bladed rotors are proven performers in the field. PACLITE PRT rider combines exceptional performance with a perfect balance.

It allows quick finishing of a large concrete surface and at the same time ensuring it is flat and smooth.

FEATURES AND BENEFITS

- Independent manual pitch control.
- Raised foot pedals.
- Powered retardant spray system.
- Centrifugal clutch.
- Five blade spider with heavy duty gearbox.
- Four lights.
- Safety switch built-in the seat.
- Epoxy painted structure.
- Option: transport trolley with inflatable wheels.



POWERED by
HONDA
norm SAE J1349

Code	PRT168
Model	PRT168
Dimension L x W x H (mm)	1980 X 1040 x 1350
Operating weight (kg)	333
Panning path width (mm)	1880
Rotors diameter (mm)	914
Maximum rotor speed (rpm)	110 To 135
Engine	Honda GX690
Net power hp (kW)	22,1 (16,5)
Rated engine speed (rpm)	3600
Fuel tank capacity (l)	23
Engine oil capacity (L)	1,9
Fuel consumption at rated power (L/h - rpm)	6,7 - 3600
Spray system	Pressurized
Application	Finishing/panning
Hand vibration (m/s ²)	3
Rated Power kW (hp)	16,5 (22,1)
Foot vibration (m/s ²)	5,73
Seat vibration (m/s ²)	2,76
Sound level guaranteed dB (A)	86,8
Sound pressure level dB (A)	55
Certified power SAE J 1349	

Options	Code
Trowel pans with 8 inserts for left and right rotor (2 per machine)	PRT168M-04712
Set of 4 blades (8 blades per machine)	947-050000
Slings 6 inches 150 mm	PRT168M-035461
Transport wheels 'Dolly jacks' 2/set	PRT168M-027684



Two water tanks



Transport wheels 'Dolly jacks'



Cup holder



Electric spray system in handle

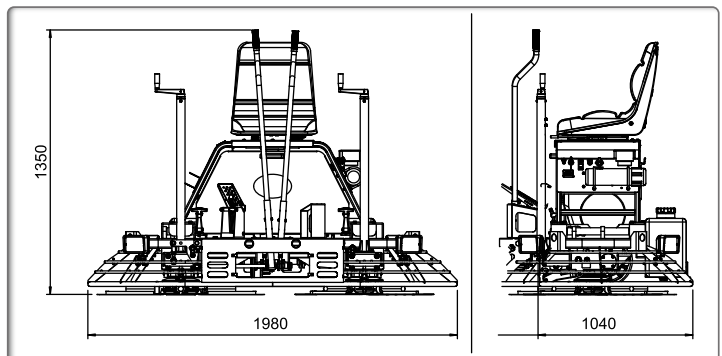

High quality Blades and Discs to get the best performance from your Pro Trowel.

PACLITE trowel blades are made out of blue steel to offer endurance and the most resistant quality in the industry. Our blades are made with extra polished rivets which ensure stability against the concrete surface avoiding resistance to bending. Purchase only original PACLITE accessories!

FEATURES AND BENEFITS

- Quality expendable blades, pans and discs.
- Competitive prices.
- Accurate fit and genuine parts.
- Blades and pans interchangeable with most other brands.
- PACLITE supplier of your trowel blades no matter the machine type.



USE ONLY ORIGINAL PACLITE PARTS
Manufactured by PACLITE



Pan Dimensions				
Code	Model/Type	Size (mm)	Insert	
TOL606-040803P	M600	610	M6	
TOL100GB-080000P	M900	980	M8	
TOL120GB-080000P	M1200	1200	M8	

Blade Dimensions				
Code	Model/Type	Size (mm)	Insert	
TOL606-050100	M600	230 x 120	M6	
TOL 700-070100	M700			
M900-050000	M900/Combination	355 x 199	M8	
947-050000	M900/Finish	356 x 151	M8	
FS9043	Clip-on extension blades 900 mm	355 x 199	Clip type	
C900-FLEX	Combi-blades, floating screw, fits all trowels	355 x 199	M8	
TOL120GB-050000	M1200/Finish	458 x 152	M8	
947-99956	Combination blades for M1200	439 x 199	M8	
FS12043	Clip-on extension blades	439 x 199	Clip type	

Clip-on extension blades are mounted on finishing blades to allow a larger trowel surface.



The flat surface is the top result.

Machines that enable professionals to literally and figuratively – go any way they want. The SUPER-SCREED is light yet robust and very easy to handle – therefore, manoeuvring is simple. The machines guarantee maximum reliability and high productivity. Perfectly levelled, flat floors; regardless how big or small the surface area is.

FEATURES AND BENEFITS

- Levelling without guiding rails.
- Protected and integrated eccentric element.
- Adjustable handle with mounted throttle.
- Foldable drive unit.
- Perfectly chromed frame, easy to clean.
- Two standards lengths 1,8 m and 3,6 m.

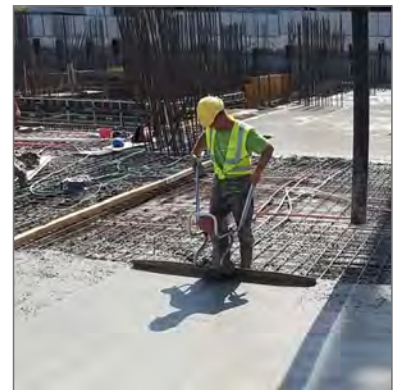

Code	400.00.10000	400.00.18000	400.00.36000
Model	Drive unit & Blade	Blade 1,8 m	Blade 3,5 m

Code	400.00.10000
Model	SUPER-SCREED
Weight (kg)	15,5
Engine	Honda GX35
Type of engine	Four stroke gasoline air cooling 1 cylinder
Cylinder (cm³)	35,8
Engine power kW (hp)	1,2 (1,6)
At (rpm)	7000
Capacity of fuel tank (l)	0,65
Consumption of fuel (l/h)	0,6
Length (mm)	1117
Width (mm)	889
Hand-arm vibration according to ISO 5349 on fresh concrete (m/s²)	3,1
Guaranteed sound-power level, LWA dB (A)	83
Sound pressure level (at operator's ear) dB (A)	70



Surface Screed

Machines that enable professionals to literally and figuratively – go any way they want. They are light yet robust and easy to handle therefore, manoeuvring is simple. The machines guarantee maximum reliability and high productivity. Perfectly levelled, flat floors; regardless of surface size.

FEATURES AND BENEFITS

- Maximum reliability and productivity.
- Easy to use.
- For perfectly flat floors.

POWERED by
HONDA
norm SAE J1349



Code	PACLI10660.2	PACLI10.660.3	10.654.3
Model	VVL200	VVL300	VVL -E 230V
Dimensions L x W x H (mm)	2000 x 430 x 295		
Weight (kg)	17	23	20
Engine	Honda GX25 - 4 stroke-gasoline		Electric
Engine power - (W)	740		1,4 ch - 0,04 KW
Frequency (Hz)	100		50
Certified power SAE J 1349			

Concrete floats, Hand tools

Smooth or texture wet concrete to the required finish. Just twist the long handle and the swivel head angles the blades for pushing or pulling across the slab.

BIG BLUE-TOO : tempered 'Blue' steel blade with rounded corners c/w Swivel & 3 snap fitting handles.

TEXAS CONCRETE PLACER: Aluminium head and handle.

FRESNO BROOM : with articulated turn knucklehead & shaft, combination tool for applying a consistent brushed finish. c/w Swivel & 3 snap fitting handles.

BULLFLOAT: lightweight magnesium alloy blade with reinforced section to prevent warping. c/w Swivel & 3 snap fitting handles.

FEATURES AND BENEFITS

- Telescopic and easy to assemble.
- Delivered in three components; blade, articulation and three lengths of telescopic and interchangeable handles.

Code	BT111992C	BT009989	BT750055	BT350084
Model	Big Blue-Too	Texas concrete placer	Fresno broom	Bull float
Dimensions L x l (mm)	1200 x 300	495 x 115	900 x 220	1200 x 200

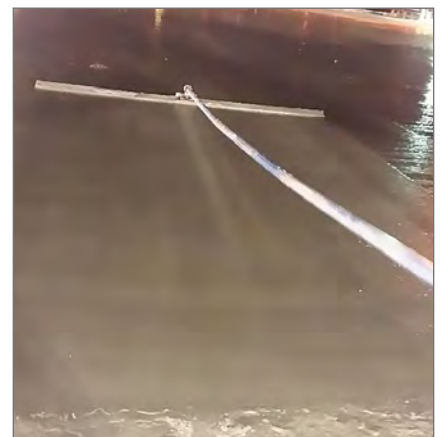
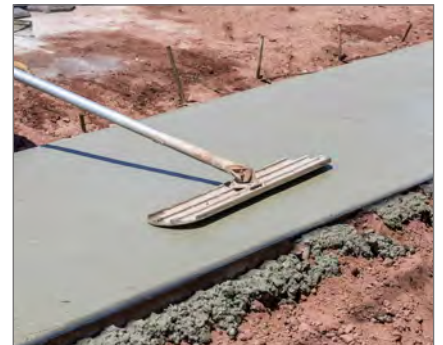

SPM-Surface Grinder

PACLITE scarifiers and tools have been well known for years but sold by our customers under other brands.

The design combines strong fabrication with heavy-duty performance.

This technique is meant for a deeper removal of material. It is ideal for the complete floor renovations of production halls, factories, farm buildings, parking lots and many other large utility buildings on both upper floor and underground levels.

FEATURES AND BENEFITS

- Etching, cleaning, paint removal on any surface.
- Can be used to remove glues, rubber and more difficult coatings.
- Ideal for road marking removal.
- Levelling of uneven concrete floors.
- Compact and easy to manoeuvre.
- Deep and precise milling of concrete, resin, asphalt.

POWERED by
HONDA
Norm SAE J1349



Code	SPM1
Model	SPMH
Dimensions L x W x H (mm)	900 x 410 x 1110
Working width (mm)	203
Weight (kg)	66
Working depth (mm)	3
Working capacity (m ² /h)	30-46
Engine	Honda GX160
Net Power hp (kW)	4,8 (3,6)
Max. speed engine (rpm)	3600
Fuel tank capacity (L)	3,1
Engine oil capacity(L)	0,6
Fuel consumption at rated power (L/h - rpm)	1,4 - 3600
Certified power SAE J 1349	

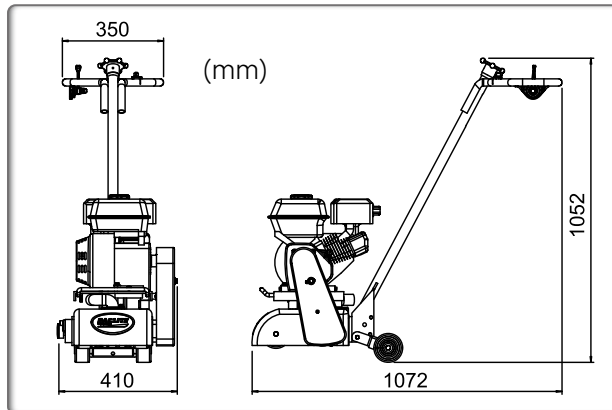

Code	Model
SPM1-070400-6	Point TC cutter (total 76 needed 8 mm high Tungsten) full set
SPM -FN W12 TC	Cutter shims (total 88 pieces needed)



Operating handle

Outlet for dust collector

Correcting a concrete floor

PACLITE CUB grinder is small floor grinder developed for correcting and rectifying any concrete surface. This machine is equipped with a powerful single-phase electric motor.

The removable diamond tool set is easy to access and replace.

The folding handle makes the machine compact and easy to transport.

FEATURES AND BENEFITS

- Tool set easy to change.
- Powerful electric motor.
- Adjustable handle.
- Outlet for connecting a dust extractor for indoor work.
- One set of diamond segments included in the machine.

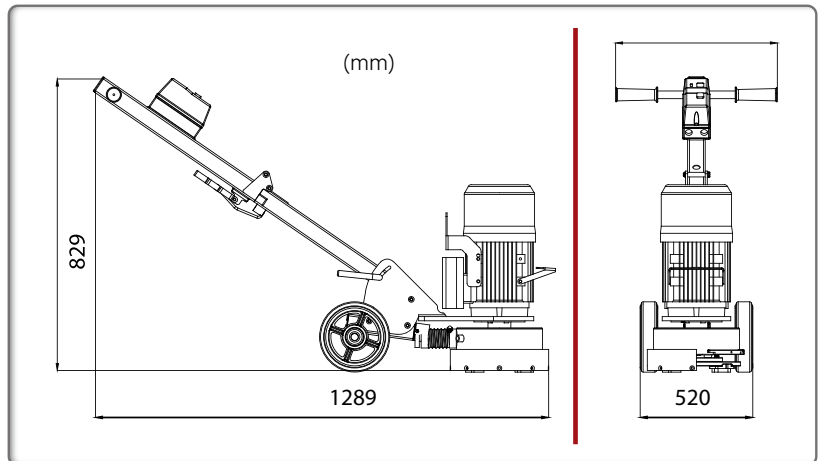

Code	CGS250-040500	BLS-HHC	BLS-SC
Option	1 Set of 5 diamond segments	For reinforced concrete SUPER HARD	Fresh concrete/abrasive

Code	PSG-SEA
Model	Cub Grinder
Working diameter (mm)	230
Segments	5
Dimensions (folded) L x W x H (mm)	800 x 460 x 700
Packing size (mm)	800 x 500 x 820
Net weight (kg)	53
Engine speed (rpm)	1430
Power source electric engine	220-240 V at 2,2 kW (3 hp) 50 Hz

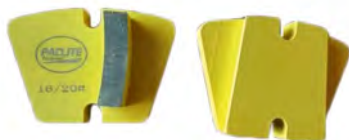
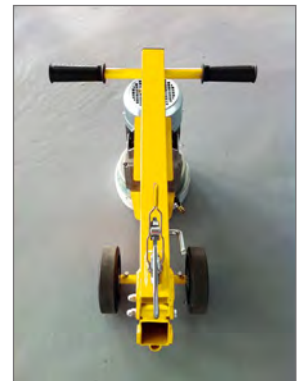
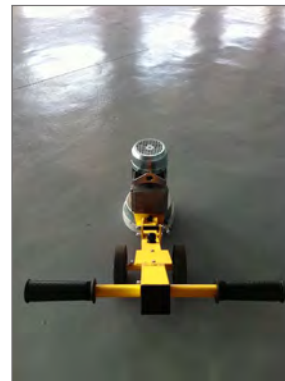

Standard segments concrete



Diamond segments easy to change, without any tools needed

Option: set of four diamond segments



PACLITE Electric multipurpose grinders

PACLITE resurfacers are versatile, perfect for a wide range of applications: removing coatings, sanding and polishing concrete.

They are also able to carry out finishes with working widths of 400 or 500 mm. Ideal for both small and large surfaces. Perfect for rental and for professional applications because of their many advantages. Available in single-phase and three-phase versions, they are suitable for industrial and domestic applications. They can be easily folded and disassembled without tools, for easy transport and storage.

FEATURES AND BENEFITS

PAC-GRIND 400

- Stable design with big wheels.
- Easily separated into two compact pieces for transportation.
- Effective and very low sound level.
- Easy to use.
- Twisting handle, electrical box with control unit
- Quick release for diamond segments
- 4-8 diamond segments according to need.
- Wet/dry grinding.

PAC-GRIND 500

- Planetary gear.
- Stable grinding.
- Big wheels.

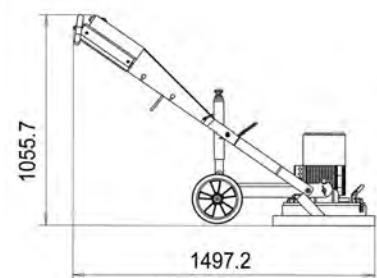
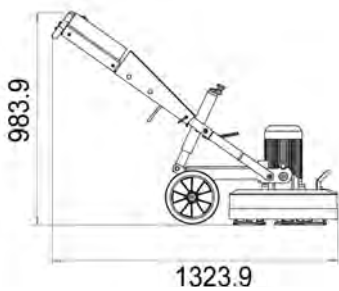

Code	TP500	TP400
Model	PAC-GRIND500	PAC-GRIND400
Power hp (kW)	3 (2,2)	5,5 (4)
Tension (V-Hz)	400-3-(50)	400 -3-(50)
Rated current (A)	16	16
Grinding diameter Ø (mm)	500	400
Number of grinding segments	9	4-8
Grinding disc Ø (mm)	3 x 150	400
Speed (RPM) (min-1)	900	1400
Weight (kg)	135	125
Option	230V-1-50Hz	No



Model	Code	Ref.	DIAMOND TOOLS
PAC-GRIND 400	TRX400	A	16 Grit hard floor 8 pieces light surface grinding
PAC-GRIND 400	TRX410	B	Epoxy or grout/bitum soft material 8 pieces deep grinding
PAC-GRIND 400	TRX420	C	Epoxy or grout/bitum soft material 8 pieces light surface correction
PAC-GRIND 500	TRX500	D	Grit soft or hard floors 9 pieces light surface grinding
PAC-GRIND 500	TRX 510	E	9 Pieces epoxy or grout/bitum soft material deep grinding
PAC-GRIND 500	TRX520	F	9 Pieces epoxy or grout / hard material removing light surface correction



PAC-GRIND 400 & PAC-GRIND 500 Standard equipment: dust cap, key for changing disc, 50 mm attachment port for an external vacuum hose, 2 m cable.

Walk-behind floor saws Ø 450 & 500 mm

Our extensive range of floor saws includes productive saws for floors, driveways, carparks, roadways, runways, new concrete, old concrete and asphalt. The blades and machines must safely and powerfully work together with the material being cut.

In addition to prioritizing the requirements of the users, we evaluate the capacity and efficiency of our equipment, allowing us to continually develop efficient solutions.

These floor saws are available with either gasoline or diesel engines.

FEATURES AND BENEFITS

- Spring loaded base plate pivot system.
- Poly-V belts for optimum power transmission.
- PACLITE floor saws are robust, well designed and easy to use thanks to features as protective cage, lift bail and cutting depth indicator.
- Raise/lower assist system, using springs.
- Engine and bladeshaft mounting system reduce vibrations and give better cutting performance.
- Bladeshaft system allows for a minimum of 250 maintenance-free hours and eliminates daily greasing of bearings.
- Spring-assist screw feed adjustment reduces the force required to adjust the blade in and out of the cut.
- Electronic hour meter.
- Integrated document and tool box.
- Front drive axle mounted with four bearings.



Ø 400, 450 & 500 mm



EN13236

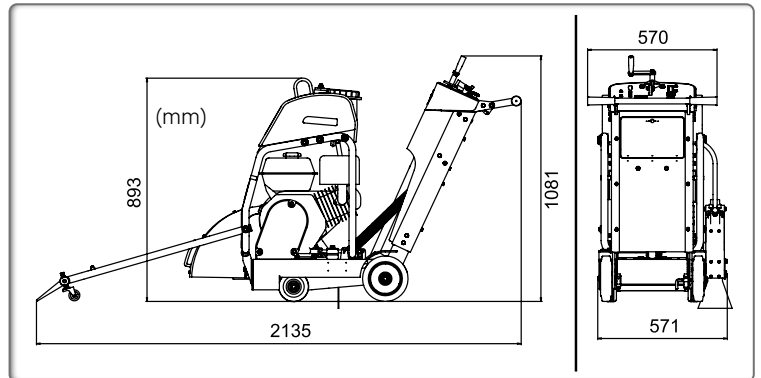

POWERED by **HONDA**
norm SAE J1349



Code	301.40.10000	301.41.10001B40	301.41.10002PAC
Model	PRECISION CUT 4-5	PRECISION CUT 500D	PRECISION CUT 500P
Dimensions L x W x H (mm)	2135 x 571 x 1081	2135 x 571 x 1081	2135 x 571 x 1081
Weight (kg)	179	199	199
Max cutting depth (mm)	146-164-192	146-164-192	146-164-192
Blade size (mm)	400-450-500	400-450-500	400-450-500
Blade speed (m/s ²)	57,6	57,6	57,6
Water tank capacity (l)	37	37	37
Engine	Honda GX390	Hatz Diesel 1B40	Kipor KM186F
Net power hp (kW)	11,7 (8,7)	11 (7,5)	11 (7,5)
Rated engine speed (rpm)	3600	3100	3600
Fuel tank capacity (L)	6,1	3	5,5
Engine oil capacity (L)	1,1	1,5	1,65
Fuel consumption at rated power (L/h - rpm)	3,5 - 3600	2,4 - 3600	2,4 - 3600

Certified power SAE J 1349



Advanced control panel with hour meter



Document and tool box



Compact design

Maximum cutting speed and smooth operation

PACLITE CUT SPEED 450 Honda floor saw offers a cutting performance second to none in this class of machines. The torque transmitted to the diamond blade and the centre of gravity located directly over the cutting shaft have been matched efficiently. The majority of the engine's power output goes there where it is needed: into the asphalt or the concrete. These two features result in cuts faster than comparable products.

FEATURES AND BENEFITS

- This machine provides excellent directional stability due to the high tensile strength of the protective cage.
- Adjustable handle makes fatigue-free positioning possible for ease of operation. The CUT SPEED 450 features a shorter wheelbase to make the handling of the machine even easier.
- The plastic removable water tank allows extended wet cuts and is the largest in this class of equipment.
- This machine is always perfectly balanced when hanging from the central lifting point for ease of transport.
- Light floor saws in their class, these units offer easy manoeuvrability around any job site.
- Electronic hour meter.
- Easily removable watering kit, centre lifting point.
- Integrated document and toolbox.

POWERED by
HONDA
norm SAE J1349



EN13236



Ø 350,400 & 450 mm



Water tank 25 L



Central lifting point



Double sprinkler



Max blade diameter 450 mm

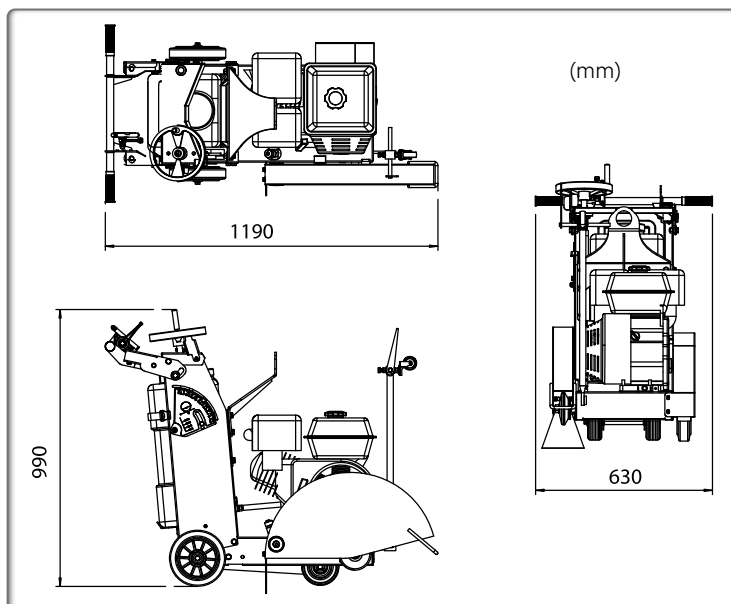

Code	301.40.10002
Model	CUT SPEED 450
Dimensions L x W x H (mm)	1190 x 630 x 990
Weight (kg)	95
Max cutting depth (mm)	145
Cutting width (mm)	10
Blade size (mm)	350, 400, 450
Blade speed (m/s ²)	46,1
Water tank capacity (L)	25
Engine	Honda GX390
Net power hp (kW)	11,7 (8,7)
Rated engine speed (rpm)	3600
Fuel tank capacity (L)	6,1
Engine oil capacity (L)	1,1
Fuel consumption at rated power (L/h - rpm)	3,5 - 3600
Certified power SAE J 1349	

The PACLITE range of high-performance diamond saw blades are one of the fastest and most productive saw blades on the market.

CONTRACT QUALITY RANGE:

Double laser welded 12 mm high segmented diamond products have been designed to give excellent speed of cut, long life and excellent value for the money. This results in excellent rental revenues per unit.

SPECIALIST RANGE: Blades that cut virtually everything on site. Designed with continuous rim and cuts fast. Multi-application blades are segmented, laser welded and provide an exceptionally long life.

TRADE RANGE: Double laser welded 10mm high diamond products. High quality blades, which have been specially designed to provide good productivity levels at the lowest possible cost per unit.

ARIX TECHNOLOGY: concrete-steel 'Cuts anything': concrete-steel-asphalt Continuous Rim. For a smooth cut with sharp edges (no chips) choose a Specialist blade for hand and tile saws.



ARIX QUALITY For reinforced concrete

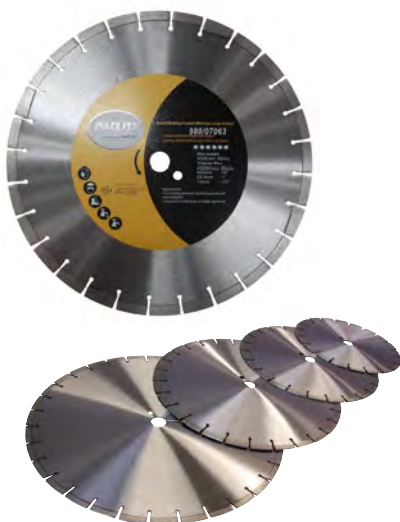

SPECIALIST RANGE laser welded 12 mm

Application		Hard Materials			
ARIX RANGE Hard materials	Code	Blade Ø (mm)	Segment W x H (mm)	Bore (mm)	
Reinforced materials for concrete	980/07128	300	2,6 x 12	20	
Reinforced materials for concrete	980/07129	350	2,6 x 12	25,4	
Contract Quality RANGE Double Laser welded		Code	Blade Ø (mm)	Segment W x H (mm)	Bore (mm)
Hard Materials	980/07022	100	2,2 x 12	16	
Hard Materials	980/07023	115	2,3 x 12	22,23	
Hard Materials	980/07024	115	2,3 x 12	22,23	
Hard Materials	980/07025	180	2,6 x 12	22,23	
Hard Materials	980/07026	230	2,6 x 12	22,23	
Hard Materials	980/07027	300	2,8 x 12	20	
Hard Materials	980/07028	350	3,0 x 12	25,4 +P	
Hard Materials	980/07029	400	3,5 x 12	25,4 +P	
Hard Materials	980/07030	450	3,5 x 12	25,4 +P	
Hard Materials	980/07031	500	3,5 x 12	25,4 +P	
Application		General Building Products			
General Building Products	980/07056	100	2,2 x 12	16	
General Building Products	980/07057	115	2,3 x 12	22,23	
General Building Products	980/07058	115	2,3 x 12	22,23	
General Building Products	980/07059	180	2,6 x 12	22,23	
General Building Products	980/07060	230	2,6 x 12	22,23	
General Building Products	980/07061	300	2,8 x 12	20	
General Building Products	980/07062	350	3,0 x 12	25,4 +P	
General Building Products	980/07063	400	3,5 x 12	25,4 +P	
General Building Products	980/07064	450	3,5 x 12	25,4 +P	
Application		Abrasive Materials			
Abrasive Materials	980/07090	100	2,2 x 12	16	
Abrasive Materials	980/07091	115	2,3 x 12	22,23	
Abrasive Materials	980/07092	125	2,3 x 12	22,23	
Abrasive Materials	980/07093	180	2,6 x 12	22,23	
Abrasive Materials	980/07094	230	2,6 x 12	22,23	
Abrasive Materials	980/07095	300	2,8 x 12	20	
Abrasive Materials	980/07096	350	3,0 x 12	25,4 +P	
Abrasive Materials	980/07097	400	3,5 x 12	25,4 +P	
Abrasive Materials	980/07098	450	3,5 x 12	25,4 +P	
Application		Asphalt			
Asphalt	980/07111	300	2,8 x 12	20	
Asphalt	980/07112	350	3,0 x 12	25,4 +P	
Asphalt	980/07113	400	3,5 x 12	25,4 +P	
Asphalt	980/07114	450	3,5 x 12	25,4 +P	
Asphalt	980/07115	500	3,5 x 12	25,4 +P	
SPECIALIST RANGE Double Laser welded		Code	Blade Ø (mm)	Segment W x H (mm)	Bore (mm)
Application		Multi Application Hard Materials & Steel			
Multi Application Hard Materials & Steel	980/07125	230	2,8 x 10	22,23	
Multi Application Hard Materials & Steel	980/07126	300	3,3 x 10	20	
Multi Application Hard Materials & Steel	980/07127	350	3,4 x 10	25,4 +P	
Application		Multi Application Cuts Everything			
Multi Application Cuts Everything	980/07135	300	2,8 x 12	22,23	
Multi Application Cuts Everything	980/07136	350	3,0 x 12	20	
Multi Application Cuts Everything	980/07137	400	3,5 x 12	25,4 +P	
Multi Application Cuts Everything	980/07138	450	3,5 x 12	25,4 +P	
TRADE RANGE Double Laser welded		Code	Blade Ø (mm)	Segment W x H (mm)	Bore (mm)
Application		General Building Products			
General Building Products	980/07065	100	2,2 x 10	16	
General Building Products	980/07066	115	2,3 x 10	22,23	
General Building Products	980/07067	115	2,3 x 10	22,23	
General Building Products	880/07068	80	2,6 x 10	22,23	
General Building Products	980/07069	230	2,6 x 10	22,23	
General Building Products	980/07070	300	2,8 x 10	20	
General Building Products	980/07071	350	3,0 x 10	25,4 +P	



BUY ONLY ORIGINAL PACLITE PART



PDF download service on the web

Download the parts view and user prices



CUSTOMER SUPPORT – OUR CONCERN AND ONLY ONE CALL AWAY

AFTER-SALES SERVICE

Following the purchase of a machine or service, after-sales service can be almost as important as the initial purchase.

Quality, price and service are three factors critical to the success of our enterprise.

Service is an integral part of **Uni-corp Europe and PACLITE Equipment**, and it has always been our strategy from the very beginning to provide first-class customer care.

We provide a professional service as it is the foundation for our future growth and the key to establishing true long-term partnerships with our customers.

Uni-corp Service includes a complete range of service, support and experienced personnel covering all your support needs in the field of compaction and concrete wherever you are.

Our wealth of experience, technical training and expertise also ensure competence and commitment in providing you with a high-class service.

Our international network is always ready to assist you in your servicing needs so that high productivity is maintained at each site.

- Product applications.
- Advice on the right product for a certain application.
- Demonstrate the product.
- Recognize key technical features.
- Find and use proper back-up material.
- Convey know-how to sales staff, distributors and endusers.
- Have basic knowledge of operational techniques.



One single phone number for after sales service

+ 33 6 42 86 50 46

sales@paclite-equip.com



Compaction
Cutting
Surfacing
Grinding
Pumping



Concrete
Lighting
Demolition
Site construction
machines



WWW.PACLITE-EQUIP.COM



UNI-Corp Europe/PACLITE Equipment

Zac Les Petits Carreaux - Bâtiment industriel n°3
12, avenue des Coquelicots
94380 Bonneuil-sur-Marne - France
sales@paclite-equip.com



of France



www.facebook.com/machinebtp

Distributor's Stamp:

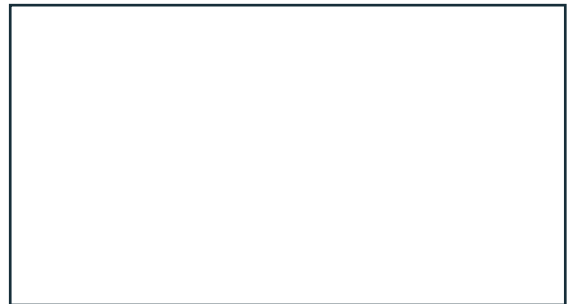

+ 33 1 49 56 02 82

+ 33 1 43 99 19 50



Design : www.steph-webdesign.com - © PACLITE - All rights reserved.