



# IMPACT430DE



## Operator's Manual

## Reversible Plate Compactor



# EC DECLARATION OF CONFORMITY / DECLARATION CE DE CONFORMITE / DECLARACIÓN DE CONFORMIDAD CE / DECLARAÇÃO CE DE CONFORMIDADE

GB/US

We, **Uni-corp Europe, 33 Avenue Pierre Brossolette, 94048 Créteil Cedex, France**, hereby certify that if the product described within this certificate is bought from an authorised Hoppt dealer within the EEA, it conforms to the following directives: Machinery Directive 2006/42/EC, Electromagnetic Compatibility Directive 2004/108/EC (as amended by 92/31/EEC & 93/68 EEC). The physical agent (vibration) conforms with the directive 2002/44/EC. The low voltage directive 2006/95/EC, BS EN ISO 12100-1/2 Safety of machinery and associated harmonised standards, where applicable. Noise emissions conform to directive 2005/88/EC Annex VI), for machines under article 12 the notified body is **TÜV Rheinland Product Safety GmbH - Am Grauen Stein - D-51105 Köln, Germany**.

F

Nous soussignons, **Uni-corp Europe, 33 Avenue Pierre Brossolette, 94048 Créteil Cedex, France**, certifions que si le produit décrit dans ce certificat est acheté chez un distributeur de la marque déposée "Hoppt" au sein de la EEA, celui-ci est conforme aux norms CEE ci-après: Norme de la machine 2006/42/CE, Norme compatible pour l'électromagnétisme 2004/108/CE (modifiée par 92/31/CEE et 93/68/CEE). Le nombre de vibrations est en accord avec la directive 2002/44/CE. Caractéristiques basse tension 2006/95/CEE, BS EN ISO 12100-1/2, Norme de sécurité des machines et des critères associés et configurés, si applicable. Les émissions de bruit sont conformes à la directive 2005/88/CE Annexe VI pour machines, article 12. L'objet mentionné est **TÜV Rheinland Product Safety GmbH - Am Grauen Stein - D-51105 Köln, Allemagne**.

E

La Sociedad, **Uni-corp Europe, 33 Avenue Pierre Brossolette, 94048 Créteil Cedex, France**, por el presente documento certifica que si el producto descrito en este certificado es comprado a un distribuidor autorizado de Hoppt en la EEA, este es conforme a las siguientes directivas: 2006/42/CE de la CEE, Directiva 2004/108/CEE sobre Compatibilidad Electromagnética (según enmiendas 92/31/CEE y 93/68 CEE). El numero de vibraciones esta de acuerdo con la Directiva 2002/44/CE. Directiva sobre Bajo Voltaje 2006/95/CEE, BS EN ISO 12100-1/2 de Seguridad de Maquinaria y Niveles armonizados estándares asociados donde sean aplicables. Emisión de Ruidos conforme a la Directiva 2005/88/CE Anexo VI para máquinas bajo artículo 12 la mencionada unidad está **TÜV Rheinland Product Safety GmbH - Am Grauen Stein - D-51105 Köln, Germany**.

P

O signatário, **Uni-corp Europe, 33 Avenue Pierre Brossolette, 94048 Créteil Cedex, France**, pelo presente, declara que se o produto descrito neste certificado foi adquirido a um distribuidor autorizado do Hoppt em qualquer país da EEA, está em conformidade com o estabelecido nas seguintes directivas comunitárias: 2006/42/CE, Directiva de Compatibilidade Electromagnética 2004/108/CEE (conforme corrigido pelas 92/31/EEC & 93/68 EEC). O numero de vibrações está de acordo com a directiva 2002/44/CE LB. A directiva de baixa voltagem 2006/95/CEE, BS EN ISO 12100-1/2 Segurança da maquinaria e às normas harmonizadas afins se aplicáveis. As emissões de ruído respeitam e estão dentro das directivas para máquinas 2005/88/CE Anexo VI, artigo 12, sendo o organismo notificado **TÜV Rheinland Product Safety GmbH - Am Grauen Stein - D-51105 Köln, Germany**.

|                   |                     |                    |                    |
|-------------------|---------------------|--------------------|--------------------|
| PRODUCT TYPE..... | TYPE DE PRODUIT.... | TIPO DE PRODUCTO.. | TIPO DE PRODUCTO.. |
| MODEL.....        | MODELE.....         | MODELO.....        | MODELO.....        |
| SERIAL No.....    | Nº DE SERIE.....    | Nº DE SERIE.....   | Nº DE SÉRIE.....   |
| DATE OF           | DATE DE             | FECHA DE           | DATA DE            |
| MANUFACTURE.....  | FABRICATION.....    | FABRICACIÓN.....   | FABRIC.....        |
| WEIGHT.....       | POIDS.....          | PESO.....          | PESO.....          |



Signed by:

Quality Manager - On behalf of Uni-corp Europe  
 Directrice de Qualité-au nom de Uni-corp Europe S.A.R.L.

**Anita Tan**

# Foreword

This manual has been written to help you operate your Reversible Plate Compactor safely. It is intended primarily for dealers and operators of Paclite Reversible Plate Compactors. It is recommended that you keep this manual or a copy of it with the machine so that it is readily available for reference.

Before you operate or carry out any maintenance on this machine YOU MUST READ and UNDERSTAND this manual.

Should you have ANY QUESTIONS about the safe use or maintenance of this machine after reading this manual, ASK YOUR SUPERVISOR or CONTACT:

Uni-corp Europe on +33(0) 1 4981 6955

Paclite reserves the right to change machine specification without prior notice or obligation.

## Directions with regard notations

Text in this manual to which special attention must be paid are shown in the following way:



**CAUTION**

This CAUTION sign indicates a potential hazard, which if ignored, could result in injuries to the operator and/or those close by, as well as damaging the machine.



**WARNING**

This WARNING sign indicates a potential hazard, which if ignored could result in the DEATH of the operator and/or those close by.

## Contents

|                                 |      |
|---------------------------------|------|
| Foreword .....                  | 2    |
| Safety Information.....         | 3-4  |
| Environment.....                | 5    |
| Machine Description.....        | 5    |
| Pre-Start Checks.....           | 6    |
| Start And Stop Procedure .....  | 6-7  |
| Operation.....                  | 7-8  |
| Service and Maintenance.....    | 9-10 |
| Transportation and Storage..... | 10   |
| Trouble Shooting.....           | 11   |
| Technical Data.....             | 12   |
| Warranty.....                   | 13   |

## Safety Information

For your own personal protection and for the safety of those around you, please read and ensure you fully understand the following safety information. It is the responsibility of the operator to ensure that he/she fully understands how to operate this equipment safely. If you are unsure about the safe and correct use of the Reversible Plate Compactor, consult your supervisor or Paclite.



**CAUTION**

Improper maintenance can be hazardous. Read and understand this section before you perform any maintenance, service or repairs.

### General Safety

- The owner of this machine must observe, and also train the user of the machine to observe, the effective labour protection laws in the country of application.
- This machine is to be used for its intended application only.
- This machine must only be operated by well-trained personnel.
- Personal Protective Equipment (PPE) must be worn by the operator whenever the equipment is being used.
- Cordon off the work area and keep members of the public and unauthorised personnel at a safe distance.
- If the surface to be compacted is on a slope, great care must be taken when controlling the machine's direction of travel. Always work up and down a slope, not across.
- Make sure you know how to safely switch this machine OFF before you switch it ON in case you run into any difficulties.
- Always switch OFF the engine before servicing it.
- This machine must be operated on the ground where stability is guaranteed. When working near the rim of excavated trenches, use the machine properly so that the machine may not collapse or fall down.
- During use, the engine becomes very hot. Always allow the engine to cool down before touching it.
- Never leave the engine running and unattended.
- Never remove or tamper with any fitted guards; they are there for your own protection. If they are damaged or missing, DO NOT USE THE MACHINE until the guard has been replaced or repaired.
- Always switch OFF the engine before transporting it, moving it around site or servicing it.
- Do not operate the machine when you are ill, feeling tired or when under the influence of alcohol or drugs.
- This machine is designed to eliminate the possible risks arising from the use of it. However, risks DO reside, and these residual risks are not clearly recognisable and may cause personal

injury or property damage, and possibly death. If such unpredictable and unrecognisable risks become apparent, the machine must be stopped immediately, and operator or his supervisor must take appropriate measure to eliminate such risks. It is sometimes necessary that the manufacturer must be informed of such an event for future counter measuring.

## Fuel Safety



Fuel is flammable. It may cause injury and property damage. Shut down the engine, extinguish all open flames and do not smoke while filling the fuel tank. Always wipe up any spilled fuel.

- Before re-fuelling, switch off the engine and allow it to cool.
- When re-fuelling, use a proper funnel, and avoid spilling over the engine.
- When re-fuelling, DO NOT smoke or allow naked flames in the area.
- Spilt fuel must be made safe immediately by using sand. If fuel is spilt on your clothes, change them.
- Store fuel in an approved, purpose made container away from heat and sources of ignition.

## Health & Safety

### Fuel

Do not ingest fuel or inhale fuel vapors and avoid contact with your skin. Wash fuel splashes immediately. If you get fuel in your eyes, irrigate with copious amounts of water and seek medical attention as soon as possible.

### Exhaust Fumes



The exhaust fumes produced by this machine are highly toxic and can kill! Make sure the work area is adequately ventilated.

Do not operate your Reversible Compactor indoors or in a confined space, make sure the work area is adequately ventilated.

### PPE (Personal Protective Equipment)

Suitable PPE must be worn when using this equipment i.e. safety goggles, gloves, ear defenders, dust mask and steel toe-capped footwear (with anti-slip soles for added protection). Wear clothing suitable for the work you are doing. Always protect skin from contact with concrete.

## Dust

The compaction process can produce dust, which may be hazardous to your health. Always wear a mask that is suited to the type of dust being produced.

## Environment

In order to protect the environment please recycle any discarded apparatus or accessories. The table beside provides you with a list of the machine's components and their respective materials. Take the discarded apparatus to the relevant recycling facilities.

| Component       | Material            |
|-----------------|---------------------|
| Handle          | Rubber              |
| Engine Base     | Ductile Iron        |
| Flexible Mounts | Steel and Rubber    |
| Various Parts   | Steel and Aluminium |



## Machine Description

1. **Control Handle**
2. **Handle bar**
3. **Throttle Lever**
4. **Filler Bore**
5. **Engine Base**
6. **Base Plate**
7. **Belt Covers**
8. **Lifting Eye**
9. **Fuel Tank**
10. **Safety cover**
11. **Engine**

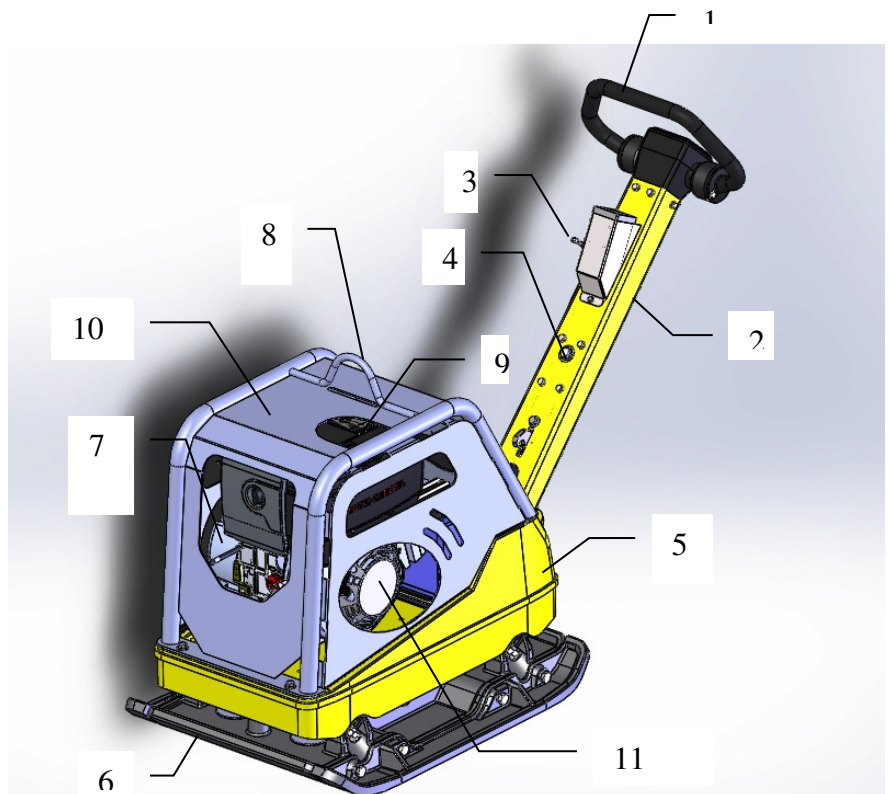

**Please note: Due to improvements and changes in the equipment, the illustrations shown may be different from the actual machine.**

## Pre-Start Checks

The following Pre-start-up inspection must be performed before the start of each work session or after every four hours of use, whichever is first. Please refer to the service & maintenance section for detailed guidance. If any fault is discovered, the Plate Compactor must not be used until the fault is rectified.

1. Thoroughly inspect the machine for signs of damage. Make sure all guards are in place and secured.
2. Check hoses, filler openings, drain plugs and any other areas for signs of leakage. Fix any leaks before operating.
3. Check the engine oil level and top up as necessary. Use proper engine oil with the proper viscosity (SAE 10W-30 recommended).
4. Check the engine fuel level and top up as necessary. Use clean fuel. Use of contaminated fuel may damage the fuel system.
5. Check the air filter is clean. Excessive dirt/dust accumulation within the filter element will cause erratic engine operation. Clean the air filter element when it is contaminated. (See Service & Maintenance Section).
6. Check for fuel and oil leaks.

## Start and Stop Procedure



Improper operation can be hazardous. Read and understand this section before you start the machine.

**Before starting the engine, make sure that the Safety Switch is in ON position, Throttle Lever is set to idle position.**

1. **Take the Reversible Compactor to where it is required. Use suitable lifting equipment to position the Reversible Compactor where it is necessary. Make sure the lifting equipment has a WLL (Working Load Limit) suitable for the Reversible Compactor weight. Attach suitable slings or chains only to the lifting point.**
2. **Never leave the engine running during transporting, even if it is for a short period of time.**
3. **Having carried out the checks listed in the 'pre-start' section, you may start the engine. Paclite Plate Compactors are fitted with a centrifugal clutch which allows the engine to run at idle speed without driving the Plate Compactor. The Centrifugal clutch will be engaged as the speed of engine is increased. For correct operation, the engine speed should be set to maximum.**



### Before Starting Gasoline Engine

1. Check the oil in the engine crankcase. Be sure to maintain the proper level per the engine manufacturer specifications. If the oil is dirty and in need of changing, follow the Engine User Manual instructions.
2. Check the fuel supply. Refer to Engine User Manual.

## Operation

1. Run the engine at full throttle and allow the Reversible Compactor to pull itself along at its normal speed.
2. When operating on an incline it may be necessary to assist the Reversible Compactor by pushing it forward slightly.
3. When operating downhill hold the Reversible Compactor back slightly, if it begins to pick up speed.
4. Depending on the material being compacted, 3 or 4 passes are recommended to achieve the best compaction.
5. While a certain amount of moisture in the soil is necessary, excessive moisture may cause soil particles to stick together and prevent good compaction.
6. If soil is extremely wet, allow it to dry somewhat before compacting.
7. If soil is so dry as to create dust clouds while operating Reversible Compactor, some moisture should be added to the ground material to improve compaction. This will also reduce service to the air filter.
8. When using the Reversible Compactor on paving stones, attach a pad to the bottom of the plate to prevent chipping or grinding surface of stones.



Do not operate the Reversible Compactor on concrete or on extremely hard, dry, compacted surfaces. The plate will jump rather than vibrate and could damage both the plate and the engine.

### Maximum Admissible Inclination

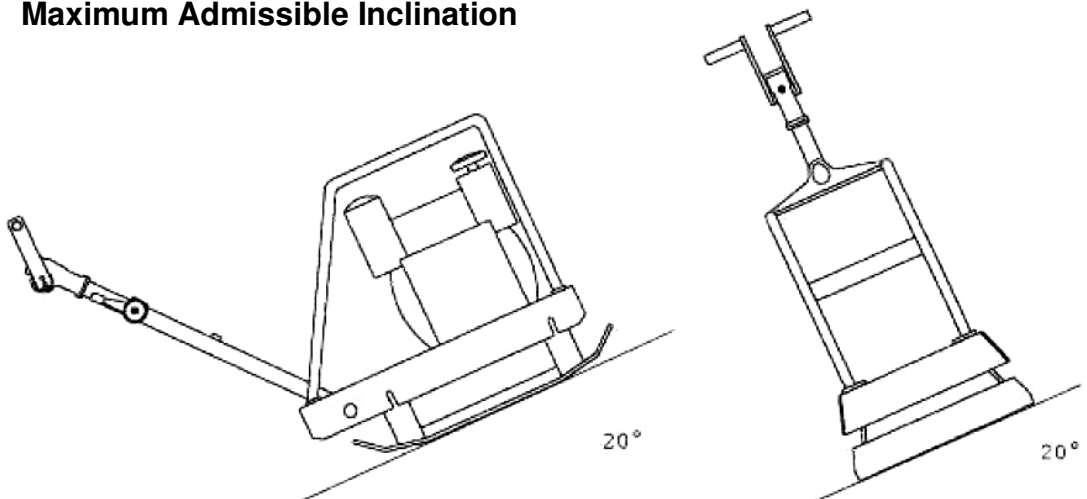

## Regarding Speed and Direction

The plate compactor has a hydraulic system which enables a gradual increase in speed. The direction of travel is determined by the control on the guide pole.

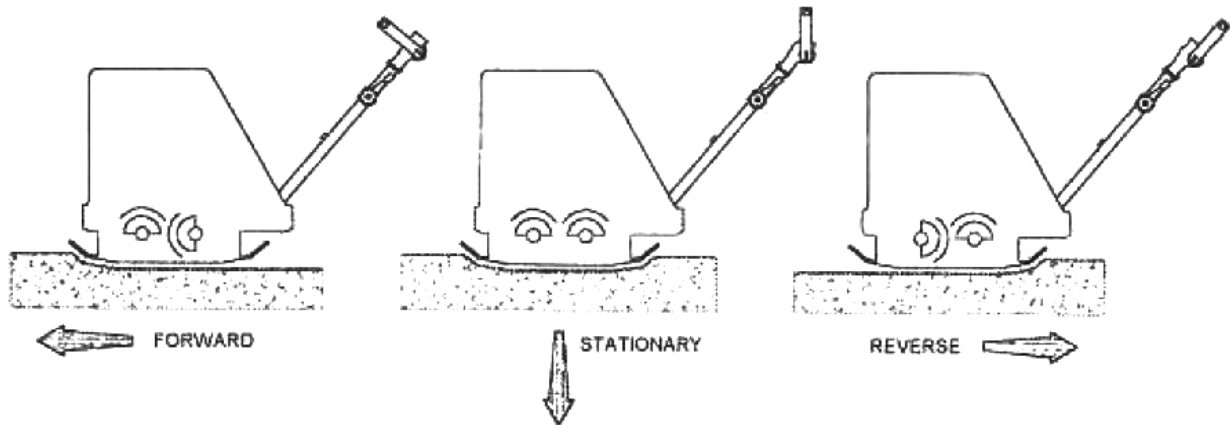

## Application

This Reversible Plate Compactor is designed for compacting loose, granular soils, gravel, paving stones and asphalt. It is intended to be used in confined areas and areas next to structures such as walls, curbs, and foundations. Reversible Compactors with water tanks can be used for compacting asphalt.

This Reversible Plate Compactor is not recommended for compacting cohesive soils with heavy clay content. For cohesive soil, use a Vibratory Rammer.

## Service and Maintenance

| Parts      | Maintenance  | Interval         |
|------------|--|------------------|
| Air filter | Check filter, clean or replace if necessary.<br>Check oil level (only for models with bathed in oil filter.) | Daily.           |
| Fuel tank  | Check tank lid fortight fit, replace if necessary.   |                  |
| Engine     | Check oil level, top up if necessary.  |                  |
| Exciter    | Check for tightness.   |                  |
| Engine     | First oil change.  |                  |
| V-belt     | Check V-belt tension.  | Monthly.         |
| Fuel tank  | Check fuel filter, replace if necessary.   | After 100 hours. |
| Engine     | Further oil changes.   |                  |
| Exciter    | Check oil level – fill up, if need be.   | After 150 hours. |
| Exciter    | Oil change.  | After 250 hours. |

### Engine Oil Change

1. Check oil level using the proper dipstick.
2. Effect oil exhaust with engine still warm.
3. Fill up until fit level.

### WARNING

Use oil with viscosity and characteristics prescribed by engine maker (look at engine manual).

### Dry Air Filter

1. To prevent carburetor malfunctions, clean regularly air filter.
2. Never use low flash point solvents for cleaning the air filter.
3. Never run the engine without the air cleaner.

### Bathed in oil air filter

1. Unhook the oil tank from filter.
2. Remove used oil and add new oil until fit level.
3. Remove dirty which is in the filter cap.
4. Clean aspiration pipe.
5. Check washer conditions, replace if necessary.

## Hydraulic system

1. Move centre pole into vertical position.
2. Open filler bore.
3. Check oil level, top up if necessary.
4. Top up with hydraulic oil T68.
5. Close filler bore.

## Transportation and Storage



Extreme Care must be taken when transporting, loading or unloading this machine.

- For long-term storage, empty the fuel in the carburetor by running the engine with the fuel tap closed.
- The chemical composition of the fuel will deteriorate after prolonged storage. When the machine needs to be stored for a long time, remove all the fuel from the fuel tank and the water from the water tank. Also remove the fuel from the float chamber of the carburetor by draining the fuel out from the drain plug.
- Wash away excessive dirt accumulated on the Reversible Compactor. Clean the engine mounting plate. Cover the machine and store it in a dry place.
- Where applicable, always use the lifting hook for hoisting purposes. Use proper hoisting equipment and techniques.
- Be certain the area surrounding the machine is clear of personnel before hoisting.

## Trouble Shooting

| <b>PROBLEMS</b>   | <b>POSSIBLE CAUSES</b>   | <b>COUNTERMEASURES</b>   |
|---|--|--|
| The machine does not go forward or goes forward slowly.                                 | Oil lack in the hydraulic pump placed on the handle.   | Place the handle in vertical position. Add hydraulic oil until the level indicated in the pump. Take off air from the circuit by lifting up and letting down the control levers sometimes. |
| The machine goes only backward.   | The joint of the pump is broken or is worn out.  | Replace the joint.   |
| The machine does not go backward or goes backward slowly.                               | There is too much oil in the hydraulic pump placed on the control handle.                            | Take off oil and restore the level indicated in the pump.  |
|   | There is some air under pressure in the pump.  | Open the pump plug in order to let air go out.   |
| The oil level in the pump is decreasing slowly.   | Loss of oil in the hydraulic conduit.  | Replace the broken part.   |
|   | The cylinder joint of the exciter is broken or worn out so the oil goes in the exciter.              | Replace the joint and restore the oil level in the exciter.  |
| The engine works regularly at fully capacity but the machine does not vibrate.          | The belt is broken.  | Replace the belt.  |
|   | The belt is loosening because it is worn out.  |  |
|   | Centrifugal clutch is broken.  | Replace the centrifugal clutch.  |
| The engine works and the exciter vibrates but the machine keeps still.                  | Mechanical failure in the exciter system.  | Open the exciter and remove the failure.   |
|   |  | Address to an Assistance Service Centre.   |
| The engines works with difficulty, smoke comes from the clutch and the exciter strains. | The mechanical parts in the exciter do not work well (worn out bearings, loss of oil, broken gears.) | Open the exciter and replace the worn out parts.   |
|   |  | Address to an Assistance Service Centre.   |
| The engine turns at minimum RPM but the exciter does not stop.                          | Centrifugal clutch is broken.  | Replace the worn out parts.  |
| Travel speed reduced or discontinuous.  | Engine RPM are over.   | Check that during work accelerator lever is set at maximum.  |
|   |  | Adjust engine RPM with appropriate tool.   |

## Technical Data

| <b>MODEL</b>  | <b>IMPACT430DE</b>                                   |
|---|--|
| OPERATING WEIGHT - kg (lb)                              | 400 (880)  |
| SHIPPING WEIGHT(INCLUDING PACKAGING)- kg (lb)           | 410(902)   |
| WORKING WIDTH - mm (in)                                 | 690(27.1)  |
| VIBRATION FREQUENCY - Hz (V.P.M.)                       | 70(70)   |
| CENTRIFUGAL FORCE - KN                                  | 55   |
| COMPACTED AREA - m <sup>2</sup> /h (ft <sup>2</sup> /h) | 820(8826)  |
| COMPACTION DEPTH (DEPENDING ON SOIL) - mm (in)          | (70~85) (2.75~3.35)                                  |
| MAX. GRADEABILITY - °                                   | 20%  |
| ENGINE  | HATZ 1B40  |
| ENGINE TYPE   | AIR- COOLED SINGLE CYLINDER 4 - STROKE DIESEL ENGINE |
| MAX. POWER OUTPUT - hp (kW)                             | 9.3(7.3)   |
| MAX. ENGINE SPEED - rpm                                 | 3600   |

=

# Warranty

Your new Paclite Reversible Compactor is warranted to the original purchaser for a period of one-year (12 months) from the original date of purchase.

The Paclite warranty covers defects in design, materials and workmanship.

## **The following are not covered under the Paclite warranty:**

1. Damage caused by abuse, misuse, dropping or other similar damage caused by or as a result of failure to follow assembly, operation or user maintenance instructions.
2. Alterations, additions or repairs carried out by persons other than Paclite or their recognised agents.
3. Transportation or shipment costs to and from Paclite or their recognised agents, for repair or assessment against a warranty claim, on any machine.
4. Materials and/or labour costs to renew, repair or replace components due to fair wear and tear.
5. The engine, air filter and the engine spark plug.

Paclite and/or their recognised agents, directors, employees or insurers will not be held liable for consequential or other damages, losses or expenses in connection with or by reason of or the inability to use the machine for any purpose.

## **Warranty Claims**

All warranty claims should firstly be directed to the local dealer, either by telephone, by fax, by email, or in writing.

## **Liability**

PACLITE declines any liability for possible damages to persons and/or things, which might arise from improper or wrong use of the machine or non-observance of the operating instructions in this manual.

# **USE ONLY GENUINE PACLITE PARTS AND ACCESSORIES!**

For your own safety, the safety of others and the life of the machine.

## Notes



## Notes

## Notes







## Uni-corp Europe S.A.R.L.

### Paclite Equipment

ZAC DES PETITS CARREAUX 12 avenue des  
Coquelicots  
94380 Bonneuil sur Marne

 +33 (0) 1 49 56 02 82

 +33 (0) 1 43 99 19 50

 [sales@paclite-equip.com](mailto:sales@paclite-equip.com)

 [Paclite-equip.com](http://Paclite-equip.com)



2011

---