

TR670H-01 FUEL TANK & HANDLE ASSY

NO.	PART NO.	PART DESCRIPTION	QTY	UNIT PRICE (EURO) 2021
01-1	TR670H-70B-010112P	FUEL TANK CAP	1	37,69 €
01-2	TR670H-70B-010113P	STRAP	1	5,10 €
01-3	TR670H-70B-010110	STRAINER	1	23,25 €
01-4	TR670H-85d-010109	FUEL TANK	1	87,53 €
01-5	TR670H-FN.B-M10x30-8.8-DIN-1	BOLT	2	0,40 €
01-6	TR670H-WOD.W10-GB-1	WASHER	2	0,25 €
01-7	TR670H-70B-000020	FUEL VALVE	1	45,64 €
01-8	TR670H-70B-000021	HOSE BAND	2	4,45 €
01-9	TR670H-70B-000022	FUEL HOSE	1	8,80 €
01-10	TR670H-85d-010100	OPERATION HANDLE	1	155,21 €
01-11	TR670H-FN.W10-DIN-1	WASHER	2	0,20 €
01-12	TR670H-IN.N-M10-DIN-1	LOCK NUT	2	0,30 €
01-13	TR670H-FN.B-M10x25-8.8-DIN-1	BOLT	4	0,35 €
01-14	TR670H-SPG.W10-DIN-1	SPRING WASHER	4	0,20 €
01-15	TR670H-FN.B-M6x20-8.8-DIN-2	BOLT	2	0,20 €
01-16	TR670H-SPG.W6-DIN-2	SPRING WASHER	2	0,20 €
01-17	TR670H-HC.N-M6-DIN-2	CAP NUT	2	0,20 €
01-18	TR670H-HC.N-M10-DIN-2	CAP NUT	1	0,50 €
01-19	TR670H-FNL.N-M10-DIN-2	HEXAGON THIN NUT	1	0,25 €
01-20	TR670H-FN.W10-DIN-2	WASHER	2	0,20 €
01-21	TR670H-70ND-060000	THROTTLE LEVER	1	24,45 €
01-22	TR670H-FHSS.S-M6x8-GB-3	SOCKET SCREW WITH FLAT HEAD	1	0,25 €
01-23	TR670H-HC.N-M8-DIN-2	CAP NUT	1	0,30 €
01-24	TR670H-FNL.N-M8-DIN-2	HEXAGON THIN NUT	2	0,20 €
01-25	TR670H-FHSS.S-M8x20-GB-3	SOCKET SCREW WITH FLAT HEAD	1	0,30 €
01-26	TR670H-70ND-060001	THROTTLE BODY	1	33,90 €
01-27	TR670H-70ND-060003	BOLT	1	13,80 €
01-28	TR670H-70ND-060002	THROTTLE GEAR	1	27,65 €
01-29	TR670H-W04-45x3	O-RING	1	5,05 €
01-30	TR670H-70ND-060004	SLIDER	1	8,15 €
01-31	TR670H-W06-S04-L450x650	THROTTLE CABLE	1	32,70 €
01-32	TR670H-65ND-010100	ROLLER	4	24,45 €
01-33	TR670H-HF.B-M5x30-8.8-DIN-3	HEXAGON FLANGE BOLT	4	0,25 €
01-34	TR670H-HF.N-M5-DIN-3	HEXAGON FLANGE NUT	4	0,20 €
01-35	TR670H-70ND-010114	STRAINER	1	20,10 €
01-36	TR670H-70ND-010115	PACKING	1	7,60 €
01-37	TR670H-85d-010113	FUEL TANK CAP ,BOTTOM	1	35,75 €
01-38	TR670H-70ND-000028	HANDLE FOAM	1	9,40 €
01-39	TR670H-70ND-000029P	HANDLE FABRIC	1	16,30 €
01-40	TR670H-70ND-010018	THROTTLE LEVER ASSY	1	84,71 €

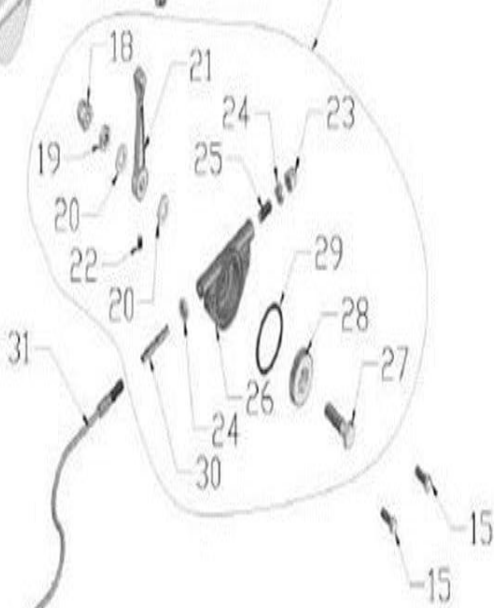
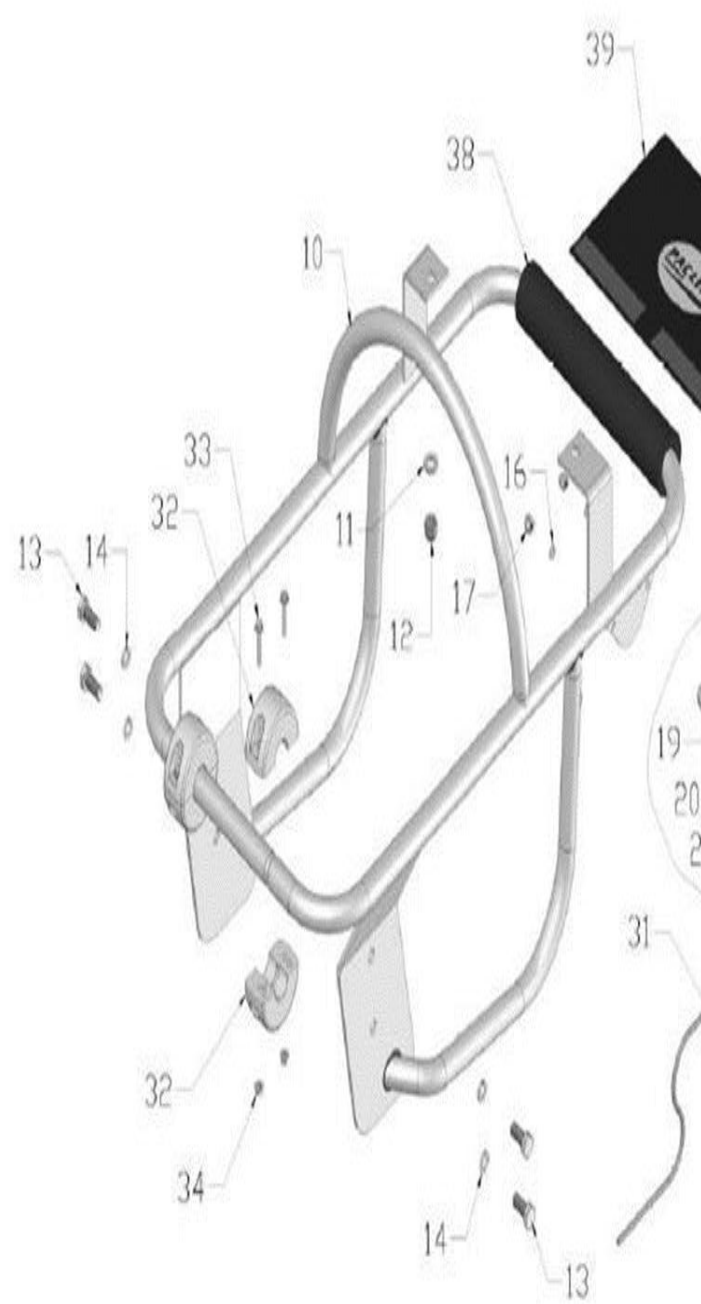
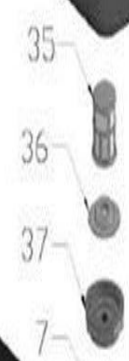
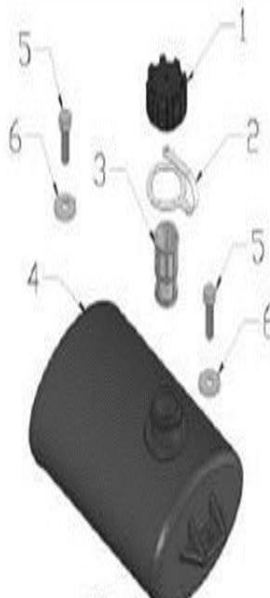

Drawn	C.J	Model	TR-670H	Drawing No.	TR-670H-01
Checked		Description	FUEL TANK & HANDLE ASSY		
Approved		Date	2009.11.10		

TR670H-02 GEAR CASE & ENGINE ASSY

NO.	PART NO.	PART DESCRIPTION	QTY	UNIT PRICE (EURO) 2021
02-1	TR670H-W05-GX120U1-KRS4	ENGINE	1	642,00 €
02-2	TR670H-80-0997	WASHER	1	5,00 €
02-3	TR670H-W18-C812A	CENTRIFUGAL CLUTCH ASSY	1	118,61 €
02-4	TR670H-WKey-4x4x13	WOODRUFF KEY	1	28,25 €
02-5	TR670H-FNL.N-M12x1.25-DIN-2	THIN NUT	1	0,35 €
02-6	TR670H-FN.B-M8x25-8.8-DIN-1	BOLT	1	0,25 €
02-7	TR670H-SPG.W8-DIN-1	SPRING WASHER	11	0,20 €
02-8	TR670H-70B-020129	LOCK WASHER	1	3,80 €
02-9	TR670H-70B-020119	CLUTCH HOUSING	1	99,75 €
02-10	TR670H-65ND-020110	SPACER	1	39,34 €
02-11	TR670H-W04-104.4x3.1	O RING	1	5,10 €
02-12	TR670H-W03-52x40x8	OIL SEAL	1	5,10 €
02-13	TR670H-W01-6207Z-J	BEARING	1	22,60 €
02-14	TR670H-CS.RG35	EXTERNAL CIRCLIP	2	0,50 €
02-15	TR670H-W01-6304-J	BEARING	1	18,90 €
02-16	TR670H-Key.A-5x5x22	KEY	1	5,10 €
02-17	TR670H-70B-020124	PINION	1	94,99 €
02-18	TR670H-65ND-020100	GEAR CASE	1	183,80 €
02-19	TR670H-70B-020106	BREATHER BOLT	1	12,60 €
02-20	TR670H-K.RVT-2.5x5	RIVET	4	0,20 €
02-21	TR670H-80-0409	NAMEPLATE	1	1,90 €
02-22	TR670H-70B-020101	WASHER	1	11,05 €
02-23	TR670H-W01-TAF324220 TR670H-RT283220	BEARING	1SET	47,06 €
02-24	TR670H-70B-020112	INTERNAL CIRCLIP	1	3,20 €
02-25	TR670H-W01-6207-J	BEARING	1	19,45 €
02-26	TR670H-CH.RG72	INTERNAL CIRCLIP	1	2,25 €
02-27	TR670H-65ND-020200	CRANK GEAR	1	238,95 €
02-28	TR670H-70B-020102	CONNECTING ROD	1	103,01 €
02-29	TR670H-W01-6204-J	BEARING	1	11,90 €
02-30	TR670H-CS.RG20	EXTERNAL CIRCLIP	1	0,25 €
02-31	TR670H-CH.RG47	INTERNAL CIRCLIP	1	0,70 €
02-32	TR670H-70B-020114	PACKING FRONT COVER	1	8,80 €
02-33	TR670H-65ND-020101P	FRONT COVER	1	51,75 €
02-34	TR670H-FN.W8-DIN-1	WASHER	14	0,20 €
02-35	TR670H-FN.B-M8x20-8.8-DIN-1	BOLT	6	0,25 €
02-36	TR670H-FN.B-M10x1.25x45-8.8-DIN-1	BOLT	3	0,45 €
02-37	TR670H-70B-020125	SHOCK ABSORBER	2	99,71 €
02-38	TR670H-HS.B-M10x35-8.8-GB-1	SCREW	4	0,40 €
02-39	TR670H-SPG.W10-DIN-1	SPRING WASHER	11	0,20 €
02-40	TR670H-FN.W10-DIN-1	WASHER	7	0,20 €
02-41	TR670H-65ND-020300	BRACKET	1	41,36 €
02-42	TR670H-FN.N-M8-DIN-1	NUT	4	0,20 €
02-43	TR670H-FN.B-M8x40-8.8-DIN-1	BOLT	4	0,30 €
02-44	TR670H-FN.B-M10x25-8.8-DIN-1	BOLT	4	0,30 €
02-45	TR670H-80-0998	LOCK WASHER	1	0,25 €

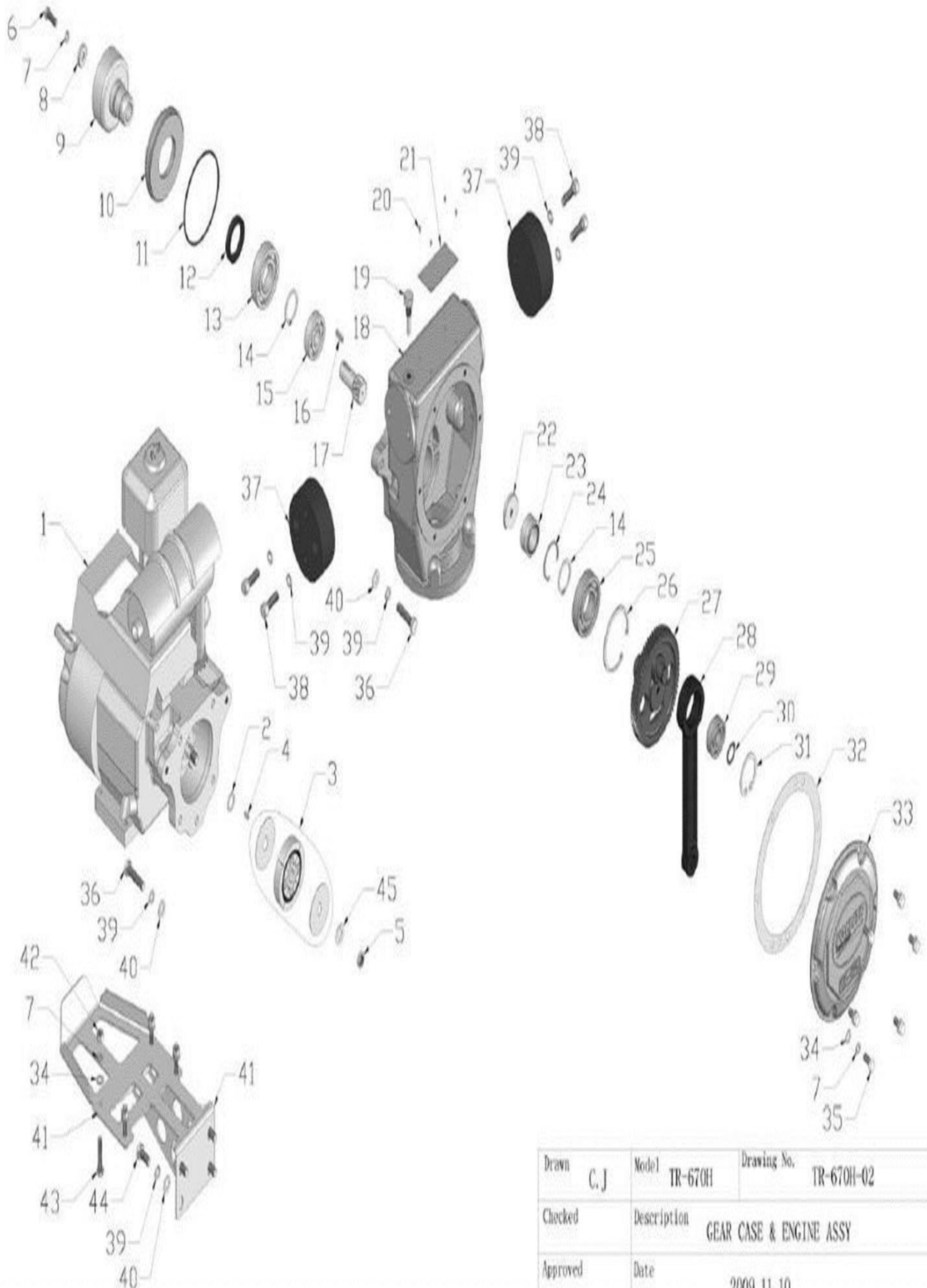

Drawn	C. J	Model	TR-670H	Drawing No.	TR-670H-02
Checked		Description	GEAR CASE & ENGINE ASSY		
Approved		Date	2009. 11. 10		

TR670H-03 GUIDE CYLINDER & SPRING ASSY

NO.	PART NO.	PART DESCRIPTION	QTY	UNIT PRICE (EURO) 2021
03-1	TR670H-65ND-020228	PISTON ROD	1	177,50 €
03-2	TR670H-70B-020215	PISTON PIN	1	33,25 €
03-3	TR670H-CS.RG16	EXTERNAL CIRCLIP	2	0,25 €
03-4	TR670H-W04-124.4x3.1	O RING	1	5,10 €
03-5	TR670H-HHOS.B-M20x1.5	HEXAGON HEAD PLUG	1	2,55 €
03-6	TR670H-GB97.1-M20	CUPRUM WASHER	1	5,55 €
03-7	TR670H-65ND-020400	GUIDE CYLINDER (TOP)	1	205,43 €
03-8	TR670H-FN.W12-DIN-1	WASHER	4	0,20 €
03-9	TR670H-SPG.W12-DIN-1	SPRING WASHER	4	0,20 €
03-10	TR670H-HS.B-M12x45	SCREW	4	0,50 €
03-11	TR670H-70B-021000	BELLOW HOOP	2	11,95 €
03-12	TR670H-70B-020216	BELLOW	1	164,33 €
03-13	TR670H-70B-020219	SPRING GUIDE (MIDDLE)	1	40,20 €
03-14	TR670H-70B-020202	OUTTER SPRING	2	90,75 €
03-15	TR670H-70B-020201	INNER SPRING	2	73,84 €
03-16	TR670H-70B-020210	PISTON	1	49,60 €
03-17	TR670H-70B-020211	PISTON RING	2	40,99 €
03-18	TR670H-SPG.W22-DIN-1	SPRING WASHER	1	0,30 €
03-19	TR670H-FN.N-M22x1.5-DIN-3	NUT	1	1,90 €
03-20	TR670H-65ND-020500	GUIDE CYLINDER (BOTTOM)	1	234,30 €
03-21	TR670H-100GB-041000	OIL GAUGE	1	26,35 €
03-22	TR670H-HSHOS.B-G1/8	HEXAGONAL SOCKET HEAD PLUG	1	2,15 €
03-23	TR670H-70B-020223	SPRING GUIDE (BOTTOM)	1	21,95 €
03-24	TR670H-W04-90x3.5	O RING	1	5,00 €
03-25	TR670H-65ND-020225	FLANGE	1	49,88 €
03-26	TR670H-FN.W6-DIN-1	WASHER	8	0,20 €
03-27	TR670H-SPG.W6-DIN-1	SPRING WASHER	8	0,20 €
03-28	TR670H-FN.B-M6x25-8.8-DIN-1	BOLT	8	0,20 €
03-29	TR670H-70B-030102	FOOT PLATE	1	60,23 €

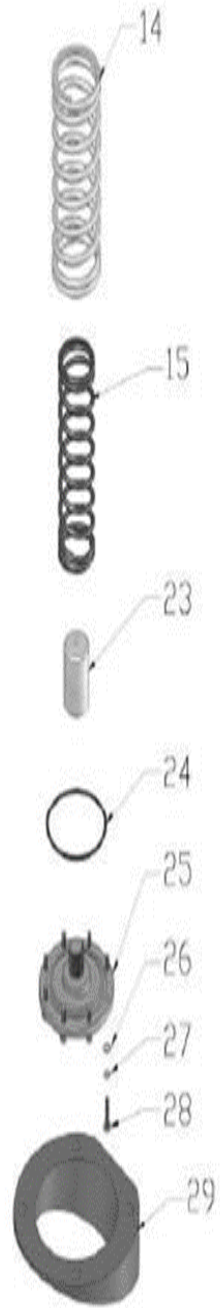
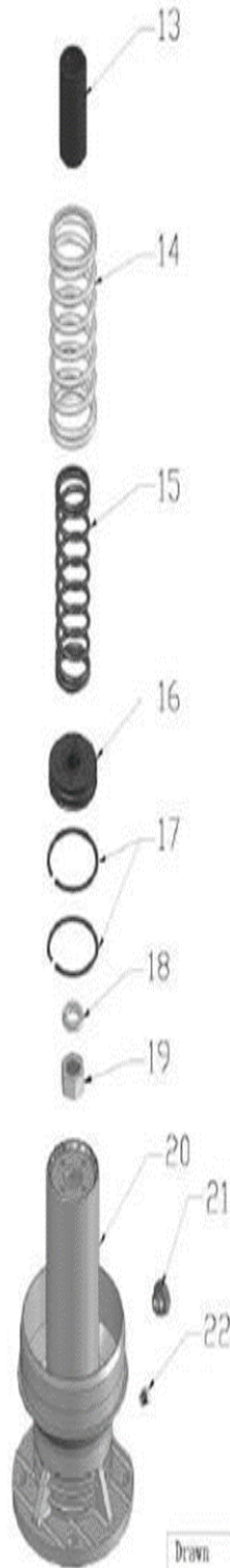
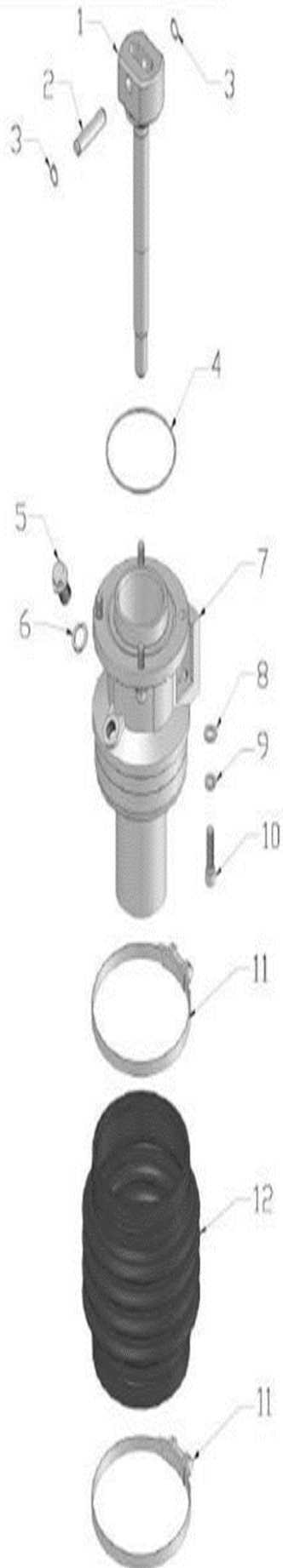

Drawn	C. J	Model	TR-670H	Drawing No.	TR-670H-03
Checked		Description	GUIDE CYLINDER & SPRING ASSY		
Approved		Date	2009.11.10		

TR670H-04 RAMMER SHOE ASSY

NO.	PART NO.	PART DESCRIPTION	QTY	UNIT PRICE (EURO) 2021
04-1	TR670H-70B-030105	RAMMER SHOE STEEL PLATE	1	316,25 €
04-2	TR670H-70B-030104	RAMMER SHOE WOODEN PLATE	1	
04-3	TR670H-70B-030101	RAMMER SHOE CLAMP PLATE	2	
04-4	TR670H-FSN.B-M12x95	SUNK HEAD BOLT	2	
04-5	TR670H-FSN.B-M12x130	SUNK HEAD BOLT	2	
04-6	TR670H-70B-030103	WASHER	4	
04-7	TR670H-FN.W12-DIN-1	WASHER	4	
04-8	TR670H-SPG.W12-DIN-1	SPRING WASHER	4	
04-9	TR670H-IN.N-M12-DIN-1	LOCK NUT	4	
04-10	TR670H-FSN.B-M10x55	SUNK HEAD BOLT	3	
04-11	TR670H-FN.W10-DIN-1	WASHER	6	
04-12	TR670H-IN.N-M10-DIN-1	LOCK NUT	7	
04-13	TR670H-WOD.W10-DIN-1	LARGE WASHER	2	
04-14	TR670H-EYE.N-M10	EYE NUT	1	
04-15	TR670H-SPG.W10-DIN-1	SPRING WASHER	1	
04-16	TR670H-FSN.B-M10x55	SUNK HEAD BOLT	5	
04-17	TR670H-65ND-030100	HANDLE	1	

