

OPERATION MANUAL

POWER TROWELS RIDE ON



PRT168M

Uni-corp Europe
PACLITE Equipment
12 avenue des Coquelicots
94380 Bonneuil sur Marne
France

www.paclite-equip.com



EC DECLARATION OF CONFORMITY I DECLARATION CE DE CONFORMITE I DECLARACIÓN DE CONFORMIDAD CE I DECLARAÇÃO CE DE CONFORMIDADE

GBIUS

We, PACLITE EQUIPMENT, ZAC des petits Carreaux, 12 Avenue des Coquelicots, 94380 Bonneuil sur Marne, **France**, hereby certify that if the product described within this certificate is bought from an authorised Paclite dealer within the EEA, it conforms to the following directives: Machinery Directive 2006/42/EC, Electromagnetic Compatibility Directive 2004/108/EC (as amended by 92/31/EEC & 93/68 EEC). The physical agent (vibration) conforms with the directive 2002/44/EC. The low voltage directive 2006/95/EC, BS EN ISO 12100-1/2 Safety of machinery and associated harmonised standards, where applicable. Noise emissions conform to directive 2005/88/EC Annex VI), for machines under article 12 the notified body is **TÜV Rheinland Product Safety GmbH - Am Grauen Stein - D- 51105 Köln, Germany.**

F

Nous soussignons, PACLITE EQUIPMENT, ZAC des petits Carreaux, 12 Avenue des Coquelicots, 94380 Bonneuil sur Marne, **France**, certifions que si le produit décrit dans ce certificat est acheté chez un distributeur de la marque déposée "Paclite" au sein de la EEA, celui-ci est conforme aux norms CEE ci-après: Norme de la machine 2006/42/CE, Norme compatible pour l'électromagnétisme 2004/108/CE (modifié par 92/31/CEE et 93/68/CEE). Le nombre de vibrations est en accord avec la directive 2002/44/CE. Caractéristiques basse tension 2006/95/CEE, BS EN ISO 12100-1/2, Norme de sécurité des machines et des critères associés et configurés, si applicable. Les émissions de bruit sont conformes à la directive 2005/88/CE Annexe VI pour machines, article 12. L'objet mentionné est **TÜV Rheinland Product Safety GmbH - Am Grauen Stein - D-51105 Köln, Allemagne.**

E

La Sociedad, PACLITE EQUIPMENT, ZAC des petits Carreaux, 12 Avenue des Coquelicots, 94380 Bonneuil sur Marne, **Francia**, por el presente documento certifica que si el producto descrito en este certificado es comprado a un distribuidor autorizado de Paclite en la EEA, este es conforme a las siguientes directivas: 2006/42/CE de la CEE, Directiva 2004/108/CEE sobre Compatibilidad Electromagnética (según enmiendas 92/31/CEE y 93/68 CEE). El numero de vibraciones esta de acuerdo con la Directiva 2002/44/CE. Directiva sobre Bajo Voltaje 2006/95/CEE, BS EN ISO 12100-1/2 de Seguridad de Maquinaria y Niveles armonizados estándares asociados donde sean aplicables. Emisión de Ruidos conforme a la Directiva 2005/88/CE Anexo VI para máquinas bajo articulo 12 la mencionada unidad está **TÜV Rheinland Product Safety GmbH - Am Grauen Stein - D-51105 Köln, Germany.**

I

Noi, PACLITE EQUIPMENT, ZAC des petits Carreaux, 12 Avenue des Coquelicots, 94380 Bonneuil sur Marne, Francia, attestiamo che se il prodotto descritto nel presente certificato è acquistato da un rivenditore Paclite autorizzato all'interno del SEE, è conforme alle seguenti direttive: Direttiva macchine 2006 / 42 / CE, Direttiva sulla compatibilità elettromagnetica 2004/108 / CE (modificata dalla 92/31 / CEE e 93/68 / CEE). L'agente fisico (vibrazione) è conforme alla direttiva 2002/44 / CE. Direttiva sulla bassa tensione 2006/95 / CE, BS EN ISO 12100-1 / 2 Sicurezza delle macchine e relative norme armonizzate, ove applicabile. Le emissioni sonore sono conformi alla direttiva 2005/88 / CE allegato VI), per le macchine di cui all'articolo 12 l'organismo notificato è TÜV Rheinland Product Safety GmbH - Am Grauen Stein - D- 51105 Köln, Germania..

PRODUCT TYPE.....	TYPE DE PRODUIT....	TIPO DE PRODUCTO..	TIPO DE PRODUCTO..
MODEL.....	MODELE.....	MODELO.....	MODELO.....
SERIAL No.....	Nº DE SERIE.....	Nº DE SERIE.....	Nº DE SÉRIE.....
DATE OF	DATE DE	FECHA DE	DATA DE
MANUFACTURE.....	FABRICATION.....	FABRICACIÓN.....	FABRIC.....
WEIGHT.....	POIDS.....	PESO.....	PESO.....



Signed by:
Signature:

Anita Tan

Quality Manager - On behalf of Uni-corp Europe
Directrice de Qualité - au nom de Uni-corp
Europe S.A.R.L.

NOTICE

This manual, or a copy of it, must be kept with the machine at all times. There is a manual storage container located on the machine for your convenience.

Riding Trowel

OPERATIONS-PARTS MANUAL

This manual covers the Riding Trowels listed below:

<u>Part No.</u>	<u>Description</u>
PRT168M	R/O Trowel, Twin 90cm, mechanical

Copyright © 2011
Uni-Corp Europe PACLITE Equipment
All rights reserved

All information, specifications, and illustrations in this manual are subject to change without notice and are based on the latest information at the time of publication. No part of this manual may be reproduced or transmitted in any form or by any means, electronics or mechanical, for any purpose, without the express written permission of Uni-Corp Europe PACLITE Equipment. Uni-Corp Europe PACLITE Equipment assumes no responsibility or liability for any errors or inaccuracies that may appear in this manual.

PACLITE Products are covered under one or more of the following patent numbers:

U.S. Design Patents: 344,736; 400,542; 400,544; 402,998; 402,999; 403,332; 404,041; 404,042; 410,931; 413,127; 416,564; 465,897; 466,909; 474,203.

U.S. Utility Patents: 5,108,220; 5,238,323; 5,328,295; 5,352,063; 5,405,216; 5,476,342; 5,480,257; 5,480,258; 5,533,831; 5,562,361; 5,567,075; 5,613,801; 5,658,089; 5,685,667; 5,803,658; 5,816,739; 5,816,740; 5,890,833; 5,934,823; 5,967,696; 5,988,938; 5,988,939; 6,019,433; 6,019,545; 6,048,130; 6,053,660; 6,089,786; 6,106,193; 6,857,815; 5,288,166; 6,582,153 B1, 7,108,449; 7,114,876; 7,316,523; 7,690,864 B2

Canadian Patents: 2,039,893.

With other Patents Pending

First Issue: June 2011
Uni-Corp Europe PACLITE Equipment Manual Part No.: 055763

Printed in France.

055763; 06/11

Limited Warranty

LIMITED WARRANTY and LIMITATION OF LIABILITY

PACLITE warrants its products to be free of defects in material or workmanship for the following periods:

- A. New Machines and Parts One Year**
- B. New Gear Boxes Two Years**

The above listed warranty periods are effective for +RSSW Machines with a first day of use by End User on April 1, 2007 or later.

Warranty period begins on first day of use by End User. This first day of use is established by the date of a completed PACLITE Warranty Card or a Bill of Sale to the End User. All warranty is based on the following limited warranty terms and conditions, including the disclaimer of implied warranties and consequential damages.

1. PACLITE's obligation and liability under this warranty is limited to repairing or replacing parts if, after PACLITE's inspection, there is determined to be a defect in material or workmanship. PACLITE reserves the choice to repair or replace.
2. If PACLITE chooses to replace the part, it will be at no cost to the customer and will be made available to the PACLITE Distributor, Dealer, or Rental Center from whom the End User purchased the product.
3. Replacement or repair parts, installed in the product, are warranted only for the remainder of warranty period of the product as though they were the original parts.
4. PACLITE does not warranty engines. Engine warranty claims should be made directly to an authorized factory service center for the particular engine manufacturer.
5. PACLITE's warranty does not cover the normal maintenance of products or its components (such as engine tune-ups and oil & filter changes). The warranty also does not cover normal wear and tear items (such as belts and consumables).
6. PACLITE's warranty will be void if it is determined that the defect resulted from operator abuse, failure to perform normal maintenance on the product, modification to product, alterations or repairs made to the product without the written approval of PACLITE. PACLITE specifically excludes from warranty any damage to any trowels resulting from an impact to the rotors.
7. Impact damage is not covered under the PACLITE Gear Box warranty.
8. PACLITE will pay shop labor on warranty items at the PACLITE Shop Labor Rate in existence on the date of the warranty claim. A PACLITE Labor Chart will determine the time allowed to complete a repair and will govern the shop labor hours that will be allowed.
9. PACLITE will pay freight on warranty replacement parts at worldwide standard ground rates. No warranty replacement parts will be shipped air freight at the expense of PACLITE. PACLITE only pays outbound freight charges when sending warranty replacement parts to the customer via ground service. PACLITE does not pay any inbound freight. However, if PACLITE determines this to be a warranted item, only then will PACLITE reimburse the customer for inbound freight at standard ground rates.
10. PACLITE'S WARRANTY POLICY WILL NOT COVER THE FOLLOWING: TAXES; SHOP SUPPLIES; ENVIRONMENTAL SURCHARGES; AIR FREIGHT; TRAVEL TIME; LOSS OF TIME; INCONVENIENCE; LOSS OF RENTAL REVENUE; RENTAL COSTS OF EQUIPMENT USE REPAIRED; LOSS OF USE OF THE PRODUCT; COMMERCIAL LOSS; OR ANY OTHER CHARGES WHATSOEVER OR ANY LIABILITIES FOR DIRECT, INCIDENTAL, OR CONSEQUENTIAL DAMAGE OR DELAY.
11. PACLITE MAKES NO OTHER WARRANTY, EXPRESSED OR IMPLIED. THIS LIMITED WARRANTY IS IN LIEU OF THE WARRANTY OF MERCHANTABILITY AND FITNESS. THERE ARE NO OTHER WARRANTIES THAT EXTEND BEYOND THE DESCRIPTION ON THIS DOC
12. No PACLITE employee or representative is authorized to change this warranty in any way or grant any other warranty unless such change is made in writing and signed by an officer of PACLITE.

Table of Contents

Sect No.	Title	Page
...	Limited Warrantyii
...	Information Contained In This Manualv
...	Dealer Informationvi
...	Ordering Partsvii
...	Model Number - Serial Number Codesviii
...	Unit Identificationix
...	Technical specificationsx
...	Engine Specificationsxvi
...	Machine Dimensional Specificationsxiii
...	Sound And Vibration Specificationsxiv
1.0	Safety1-1
...	State Regulations1-2
...	Federal Regulations1-3
1.1	General Safety Precautions1-4
1.2	Spark Arrestor Notice1-5
1.3	Operating Safety1-6
1.4	Engine Safety1-8
1.5	Servicing Safety1-9
1.6	Safety And Operation Labels1-10
2.0	Operations2-1
2.1	Introduction2-3
2.2	Start Up Procedures2-4
2.3	Operating Instructions2-6
3.0	Service3-1
3.1	Periodic Maintenance3-2
3.2	Trowel Gearbox3-3
3.3	Drive Belt3-4
3.4	Control Lever Adjustment3-8
3.5	Right Hand Control Lever Adjust3-10
3.6	Lift Lever Adjustment3-12
3.7	Transporting Trowel3-14
3.8	Battery Jump Start3-18

Table of Contents, continued

4.0	Parts	4-1
...	Factory Service Information	4-2
...	Replacement Part Procedure	4-3
4.1	Seat Frame Assembly	4-4
4.2	Mainframe Assembly	4-6
4.3	Steering Assembly	4-8
4.4	Spray System	4-10
4.5	Pitch Control Assembly	4-12
4.6	Engine System Assembly	4-14
4.7	Driveline Assembly	4-16
4.8	Electrical Schematic	4-18
4.9	Right Rotor Assembly (SOM)	4-20
4.10	Left Rotor Assembly (SOM)	4-22
4.11	Right Spider Assembly	4-24
4.12	Left Spider Assembly	4-26
4.13	Right Gearbox Assembly (SOM)	4-28
4.14	Left Gearbox Assembly (SOM)	4-30
4.15	Dolly Jack Assembly	4-32
4.16	Pans and Lifting Bridle	4-34
4.17	Tools	4-36

Information Contained in this Manual



This manual provides information and procedures to safely operate and maintain the PACLITE Machine.

For your own safety and protection from personal injury, carefully read, understand, and observe the safety instructions described in this manual. Keep this manual or a copy of it with the machine at all times.

Always operate this machine in accordance with the instructions described in this manual. A well maintained piece of equipment will provide many years of trouble free operation.

This manual is divided into the following sections:

**SECTION 1
SAFETY**

**SECTION 2
OPERATIONS**

**SECTION 3
SERVICE**

**SECTION 4
PARTS**

Complete any warranty requirements as specified by the engine manufacturer in their instructions found inside the manual tube located on the side of the seat frame.

Your engine and clutch is not manufactured by PACLITE, and therefore is not covered under the Uni-Corp Europe PACLITE Equipment

Your engine manufacturer should be contacted if you wish to purchase a parts manual or a repair manual for your engine.

Refer to enclosed owners engine manual for complete O&M instructions. See your battery manufacturer for battery warranty.

Dealer Information

Your Dealer has PACLITE trained mechanics and original PACLITE replacement parts. Always contact the PACLITE Dealer who sold you this machine for PACLITE Certified repairs and replacement parts.

Place PACLITE Dealer information below for future reference.

Dealer Name: _____

Phone #: (____) - ____ - _____

Address: _____

City: _____ State: _____ Zip: _____

Salesman: _____ Mobile Phone _____

Additional Comments: _____

Ordering Parts

Section 4.0 contains illustrated parts lists for help in ordering replacement parts for your machine. Follow the instructions below when ordering parts to insure prompt and accurate delivery:

1. All orders for service parts - include the serial number for the machine. Shipment will be delayed if this information is not available.
2. Include correct description and part number from the "PARTS" section of this manual.
3. Specify exact shipping instructions, including the preferred routing and complete destination address.
4. **DO NOT** return parts to PACLITE without receiving written authorization from PACLITE. All authorized returns must be shipped pre-paid.
5. When placing an order, please contact the PACLITE dealer nearest you.



All information, specifications, and illustrations in this manual are subject to change without notice and are based on the latest information at the time of publication.

Model Number - Serial Number Codes

Manufacturer's Codes:

When ordering parts or requesting service information, you will always be asked to specify the model and serial numbers of the machine. The legends below specifically defines each significant character or group of characters of the Model Number and Serial Number codes.

Model Number

PRT 168- M

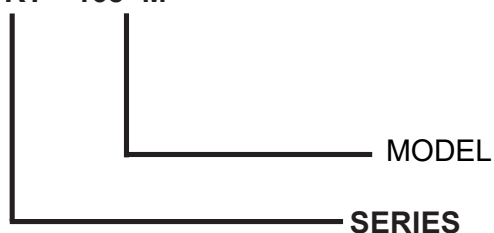

Serial Number

The serial number found on the identification plate is a ten digit format. The model number identifies your machine and will ensure that you receive the correct replacement parts.

HA1 12 09 01

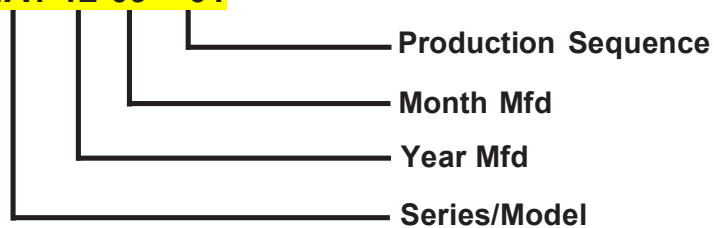

Unit Identification

Unit Identification Plate Location:

An identification plate listing the model number and the serial number is attached to each unit and is located on the left side front deck of mainframe. Refer to Figure 1 for serial number and model number location. This plate should not be removed at any time.

Please record the information found on this plate below so it will be available should the identification plate become lost or damaged. When ordering parts or requesting service information, you will always be asked to specify the model and serial numbers of the machine.

FILL IN FOR FUTURE REFERENCE

Model Number:	_____
Serial Number:	_____
Date Purchased:	_____
Purchased From:	_____

MODEL SERIES

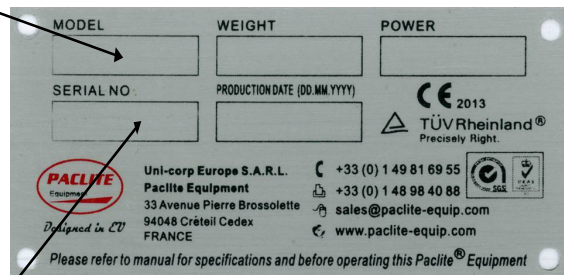

SERIAL NUMBER

Figure 1
Serial Number Location

Technical Specifications

Measurements in this manual are in U.S. units and their customary metric units (i.e., metric units contained within brackets [8 mm]). The machine RIGHT-HAND and LEFT-HAND sides are determined by sitting on machine (SOM) facing in the direction the machine will travel when going forward.

Machine Features:

- Dimensions (L x W x H) inch [mm]77.5x40.5x54
(guard rings/top of seat)[1969x1029x1372]
- MACHINE Weight lb [kg]
WITH HONDA GX690 737[335]
- Panning Path Width inch [mm]71.2 [1808]
- Two Rotors (Diameter) inch [mm]36 [914]
- Rotor Speed (RPM)110 - 135
- Finish Blade (8) inch [mm]6 x 14 [152.4x355.6]
- Gearbox (2)Standard Duty (STD)
- Fixed Guard RingsStandard
- Fixed Seat FrameStandard
- Powered Retardant Spray SystemStandard
- Spray System Capacity gal [L]6 [23]
- Steering SystemDual Levers
- Gearbox RotationStandard
- Battery12 Volt
- Safety Shutdown SwitchSeat Controlled
- Fuel Capacity gal [L]6 [23]
- Run Time (Approximate) hr2.5

Technical Specifications, continued

- Transmission TypeTorque Converter Clutch
- Drive Belt TypeKevlar Cogged Vee
- Hour Meter TypeDigital Read-out

Engine Specifications

Honda Engine Information

- ModelGX-690 R TDW
- Rated Power hp [kW] @ 3,600 RPM22.3 [16.6]
- Displacement in³ [cm³]42 [688]
- Dimensions (L x W x H) inch [mm]15.9x16.1x17.2 [405x410x438]
- Fuel (Type)Regular unleaded gasoline
- Weight (Dry) lb [kg]98 [44.4]



Machine Dimensional Specifications

All information, specifications, and illustrations on this page in this manual are subject to change without notice and are based on the latest information at the time of publication.

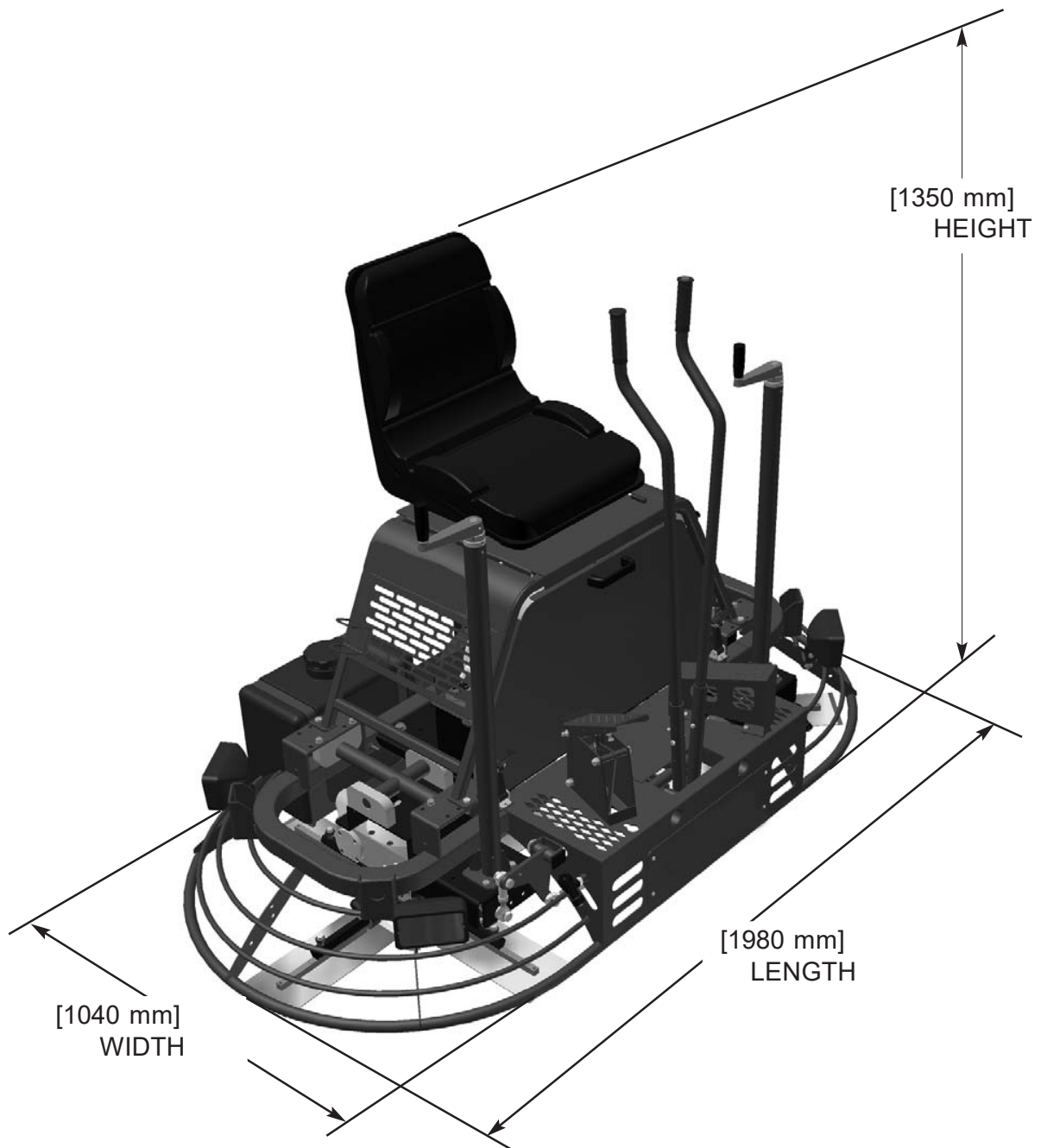

CE Sound And Vibration Data



Sound Pressure Level Information:

Sound pressure is "A" weighted . Measured at the operators ear position while the ride-on trowel is operating at full throttle on concrete in a manner most often experienced in "normal " circumstances. Sound pressure may vary depending upon the condition of the concrete. Hearing protection is always recommended.



Vibration Level Information:

The vibration level indicated is the maximum RMS (Root Mean Square) velocity value obtained at the handle grip while operating the ride-on trowel on curing concrete in a manner most often experienced in "normal " circumstances. Values were obtained from all three axes of motion. The values shown represent the maximum RMS value from these measurements.

Summary Data Of Sound And Vibration Testing for CE Marking

Test Machine	Engine Type	Distant Sound Press	Operator Ear SPL	Sound Power Level	Seat Vibration Overall	Foot Vibration Overall	Hand Vibration Maximum
MP215	Honda	dB (A) 55	dB (A) 86.9	dB (A) 86.8	m/sec ² 2.76	m/sec ² 5.73	m/sec ² 3.00
This information was acquired from sound and vibration analysis tests conducted at Allen Engineering Corporation test facilities.							



Section 1
SAFETY

SECTION 1
SAFETY

State Regulations



CALIFORNIA PROPOSITION 65
WARNING

Gasoline engine exhaust from this product contains chemicals known to the State of California to cause cancer, birth defects and other reproductive harm.



WARNING

SILICOSIS WARNING

Grinding/cutting/drilling of masonry, concrete, metal and other materials with silica in their composition may give off dust or mists containing crystalline silica. Silica is a basic component of sand, quartz, brick clay, granite and numerous other minerals and rocks. Repeated and/or substantial inhalation of airborne crystalline silica can cause serious or fatal respiratory diseases, including silicosis. In addition, California and some other authorities have listed respirable crystalline silica as a substance known to cause cancer. When cutting such materials, always follow the respiratory precautions mentioned above.

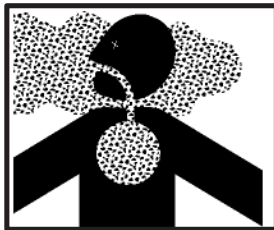

WARNING

RESPIRATORY HAZARDS

Grinding/cutting/drilling of masonry, concrete, metal and other materials can generate dust, mists and fumes containing chemicals known to cause serious or fatal injury or illness, such as respiratory disease, cancer, birth defects or other reproductive harm. If you are unfamiliar with the risks associated with the particular process and/or material being cut or the composition of the tool being used, review the material safety data sheet and/or consult your employer, the material manufacturer/supplier, governmental agencies such as OSHA and NIOSH and other sources on hazardous materials. California and some other authorities, for instance, have published lists of substances known to cause cancer, reproductive toxicity, or other harmful effects.

Control dust, mist and fumes at the source where possible. In this regard use good work practices and follow the recommendations of the manufacturers or suppliers, OSHA/NIOSH, and occupational and trade associations. Water should be used for dust suppression when wet cutting is feasible. When the hazards from inhalation of dust, mists and fumes cannot be eliminated, the operator and any bystanders should always wear a respirator approved by NIOSH/MSHA for the materials being used.

SECTION 1 SAFETY

1.1 General Safety Precautions

1.1.1 Safety-Alert Signs

This manual contains Safety-Alert Signs, as defined below, which must be followed to reduce the possibility of improper service damage to the equipment or personal injury. Read and follow all Safety-Alert Signs included in this manual.



NOTE defines an operating procedure, condition, etc. which is essential to highlight that contains useful or important information.



EMERGENCY is used for the identification of safety equipment, first aid, or emergency egress locations.



NOTICE used to convey safety information on labels and signs.



CAUTION is indicative of a potentially hazardous situation which, if not avoided, may result in minor or moderate injury.



Potentially hazardous situations that could result in death or serious injury are indicated by the word WARNING.



DANGER indicates an imminently hazardous situation which, if not avoided, will result in death or serious injury.

1.2 Spark Arrestor Notice

SECTION 1 SAFETY

1.2.1 Laws Pertaining to Spark Arrestors

Some states require that in certain locations arrestors be used on internal combustion engines. A spark arrester is a device designed to prevent the discharge of spark or flames from the engine exhaust. It is often required when operating equipment on forested land to prevent the risk of fires. Consult the engine distributor or local authorities and make sure that you comply with regulations regarding spark arrestors.

SECTION 1 SAFETY

1.3 Operating Safety

1.3.1 Operating Safety



Familiarity and proper training are required for the safe operation of this equipment! Equipment operated improperly or by untrained personnel can be dangerous! Read the operating instructions contained in both this manual and the engine manual and familiarize yourself with the location and proper use of all controls.

- 1.3.2 **NEVER** operate this machine in applications for which it is not intended.
- 1.3.3 **NEVER** allow anyone to operate this equipment without proper training. People operating this equipment must be familiar with the risks and hazards associated with it.
- 1.3.4 **NEVER** touch the engine or muffler while the engine is on or immediately after it has been turned off. These areas get hot and may cause burns.
- 1.3.5 **NEVER** use accessories or attachments that are not recommended by PACLITE. Damage to equipment and injury to the user may result.
- 1.3.6 **NEVER** operate the machine with the beltguard missing. Exposed drive belt and pulleys create potentially dangerous hazards that can cause serious injuries.
- 1.3.7 **NEVER** leave machine running unattended.
- 1.3.8 **DO NOT** run the machine indoors or in an enclosed area such as a deep trench unless adequate ventilation, through such items as exhaust fans or hoses, is provided. Exhaust gas from the engine contains poisonous carbon monoxide gas; exposure to carbon monoxide can cause loss of consciousness and may lead to death.
- 1.3.9 **ALWAYS** remain aware of moving parts and keep hands, feet, and loose clothing away from the moving parts of the equipment.
- 1.3.10 **ALWAYS** keep hands, feet, and loose clothing away from moving parts of the machine.
- 1.3.11 **ALWAYS** read, understand, and follow procedures in the Operator's Manual before attempting to operate the equipment.
- 1.3.12 **ALWAYS** be sure operator is familiar with proper safety precautions and operation techniques before using machine.

1.3, continued Operating Safety

SECTION 1 SAFETY

- 1.3.13 **ALWAYS** close fuel valve on engines equipped with one when machine is not being operated.
- 1.3.14 **ALWAYS** store the equipment properly when it is not being used. Equipment should be stored in a clean, dry location out of the reach of children.
- 1.3.15 **ALWAYS** operate the machine with all safety devices and guards in place and in working order.

SECTION 1 SAFETY

1.4 Engine Safety

1.4.1 Engine Safety



Internal combustion engines present special hazards during operation and fueling. Read and follow the warning instructions in the engine owner's manual and the safety guidelines below. Failure to follow the warnings and safety guidelines could result in severe injury or death.

- 1.4.2 **DO NOT** run the machine indoors or in an enclosed area such as a deep trench unless adequate ventilation, through such items as exhaust fans or hoses, is provided. Exhaust gas from the engine contains poisonous carbon monoxide gas; exposure to carbon monoxide can cause loss of consciousness and may lead to death.
- 1.4.3 **DO NOT** smoke while operating the machine.
- 1.4.4 **DO NOT** smoke when refueling the engine.
- 1.4.5 **DO NOT** refuel a hot or running engine.
- 1.4.6 **DO NOT** refuel the engine near an open flame.
- 1.4.7 **DO NOT** spill fuel when refueling the engine.
- 1.4.8 **DO NOT** run the engine near open flames.
- 1.4.9 **ALWAYS** refill the fuel tank in a well-ventilated area.
- 1.4.10 **ALWAYS** replace the fuel tank cap after refueling.
- 1.4.11 **ALWAYS** keep the area around the muffler free of debris such as leaves, paper, cartons, etc. A hot muffler could ignite the debris and start a fire.

1.5.1 Service Safety



Poorly maintained equipment can become a safety hazard! In order for the equipment to operate safely and properly over a long period of time, periodic maintenance and occasional repairs are necessary.

- 1.5.2 **DO NOT** attempt to clean or service the machine while it is running. Rotating parts can cause severe injury.
- 1.5.3 **DO NOT** crank a flooded engine with the spark plug removed on gasoline-powered engines. Fuel trapped in the cylinder will squirt out the spark plug opening.
- 1.5.4 **DO NOT** test for spark on gasoline-powered engines if the engine is flooded or the smell of gasoline is present. A stray spark could ignite the fumes.
- 1.5.6 **DO NOT** use gasoline or other types of fuels or flammable solvents to clean parts, especially in enclosed areas. Fumes from fuels and solvents can become explosive.
- 1.5.7 **ALWAYS** turn engine off and remove key from machine before performing maintenance or making repairs.
- 1.5.8 **ALWAYS** handle blades carefully. The blades can develop sharp edges which can cause serious cuts.
- 1.5.9 **ALWAYS** keep the area around the muffler free of debris such as leaves, paper, cartons, etc. A hot muffler could ignite the debris and start a fire.
- 1.5.10 **ALWAYS** replace worn or damaged components with spare parts designed and recommended by PACLITE.
- 1.5.11 **ALWAYS** disconnect the spark plug on machines equipped with gasoline engines, before servicing, to avoid accidental start-up.
- 1.5.12 **ALWAYS** switch off the power supply at the battery disconnect before adjusting or maintaining the electrical equipment.
- 1.5.13 **ALWAYS** keep the machine clean and labels legible. Replace all missing and hard-to-read labels. Labels provide important operating instructions and warn of dangers and hazards.

SECTION 1 SAFETY

1.6 Safety and Operation Labels

The safety and operation labels shown in this section are placed in important areas on the machine to draw attention to potential safety hazards and service information. Should any of these labels become unreadable or damaged, replacement labels can be ordered from your distributor.

CAUTION

This is a multi-purpose label that requires the operator to have maximum eye, hearing, hand, and feet protection. Also, it highly recommends that the operator reads the manual.



WARNING

This label identifies the lift locations on the machine. No other locations or features on the machine are to be used as lifting points. This will cause damage to the machine.

**LIFT HERE
ONLY**

032159

NOTE

This label identifies the tank used for retardant spray agents (i.e., water-based retardants) only on the machine. **NO OTHER** non-retardant chemicals nor fuel is to be in this tank.

**RETARDANT
ONLY**

CAUTION

For gasoline-fueled machines, this label identifies the tank used for **GASOLINE** fuel only in the machine. **NO OTHER** type of fuel is to be used in this tank.

**GASOLINE
ONLY**

019426

1.6, continued Safety and Operation Labels

SECTION 1 SAFETY

NOTE

This label is a maintenance reminder to grease the thrust bearing daily. This will ensure that the life span of the bearings will be maintained at their optimal performance level.

**GREASE THRUST
BEARING DAILY**

039778

CAUTION

This label cautions against allowing cleaning agents, surface treatments, or other foreign substances to contaminate drive components.

The drive components could be damaged from the contamination and cause the drive system to fail.

CAUTION

DO NOT ALLOW CLEANING AGENTS,
SURFACE TREATMENTS, OR FOREIGN
SUBSTANCES TO CONTAMINATE
DRIVE COMPONENTS

DRIVE COMPONENTS COULD BE DAMAGED
AND CAUSE THE DRIVE SYSTEM TO FAIL

047878

**SECTION 1
SAFETY**

**1.6, continued
Safety and Operation Labels**

⚠ WARNING

This label warns of the risk hazards associated with engine exhaust fumes causing health issues as identified by the State of California.

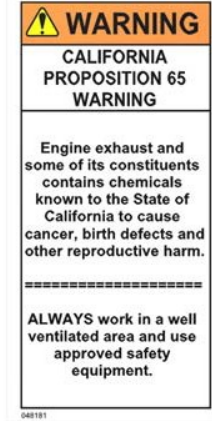

Section 2
OPERATIONS

SECTION 2 OPERATIONS

NOTE

This machine is built with user safety in mind. However, it can present hazards if improperly operated and serviced. Follow operating instructions carefully.

If you have any questions about operating or servicing this equipment, please contact PACLITE Customer Service.



2.1.1 Description

The **PRT168M** riding trowel is a modern high production machine. Finishing rates will vary depending on the operators' skill and job conditions. This riding trowel has eight finishing blades.

The standard duty gearboxes are designed to provide exceptional performance with low maintenance and trouble free use under some of the worst conditions.

All PACLITE **PRT 168M** are equipped with a safety shutdown switch and a low oil warning light for added job safety and engine protection. Operating time between fuel refills is approximately 2-1/2 to 3 hours with a rotor speeds of 110 to 135 RPM.

The **PRT 168M** are the most technically advanced riding trowels on the market today. With proper maintenance and use, your riding trowel will provide you with exceptional service and dependability.

2.9.1 Before Starting Procedures

Before starting the riding trowel check for the following:

- 1) Oil level in engine.
- 2) Oil level in riding trowel gearboxes.
- 3) Fuel level in fuel tank.
- 4) Condition of riding trowel arms and blades.
- 5) Verify that daily maintenance of grease points have been performed.

2.9.2 Starting Procedures

Before starting riding trowel, refer to Figure 2.2.1 and Figure 2.2.2 for location and identification of operational and visual controls pertaining to the operation of the riding trowel.

- 1) Sit down correctly on the riding trowel seat. **DO NOT** attempt to start the riding trowel without an operator in the seat.
- 2) If engine is cold, pull out the choke lever located in the control zone (refer to Figure 2.2.1). Press down on throttle pedal (located by the operator's right foot) one to two times.



Too much throttle during start-up will flood the engine.

- 3) Turn ignition switch key to the start-position, immediately release key when engine starts. If after two or three attempts the engine has not started push in choke. Attempt to start trowel again. Allow engine to warm up for 5 minutes before operating riding trowel.



Operating the starter for more than 5 seconds can damage the starter or engine. If engine fails to start release the switch and wait 15 seconds before operating starter again.

2.2, continued Start Up Procedures

SECTION 2 OPERATIONS

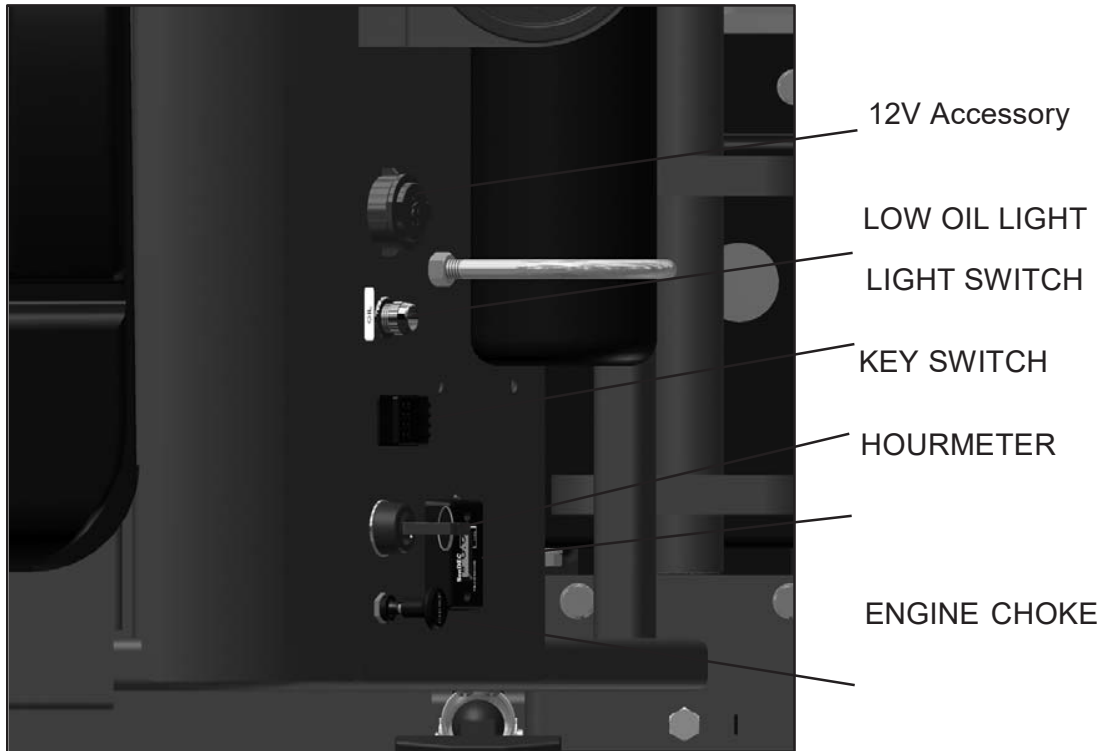

FIGURE 2.2.1
TOP VIEW OF CONTROLS

SECTION 2 OPERATIONS

2.3 Operating Instructions

2.3.1 Operating The Riding Trowel

To utilize your PACLITE *PRT 168MRider* to its fullest capacity the machine should be driven in the direction the operator is facing. This will finish the widest possible area while giving the operator an excellent view of the slab surface about to be troweled. When the machine reaches the end of the slab make a 180 degree turn and repeat the straight line of direction to the other end of the slab. To familiarize a new operator with the riding trowel the following steps should be taken.

! NOTE

All items in this manual are described from the operator Sitting On Machine or SOM for short.

1) Location of all Operating Controls

- [A] Right Pitch Control
- [B] Joystick (Forward & Reverse)
- [C] Joystick (Left & Right, Forward & Reverse)
- [D] Left Pitch Control
- [E] Right Foot - Throttle
- [F] Left Foot Rest
- [G] Seat Adjustment
- [H] Tool Holder

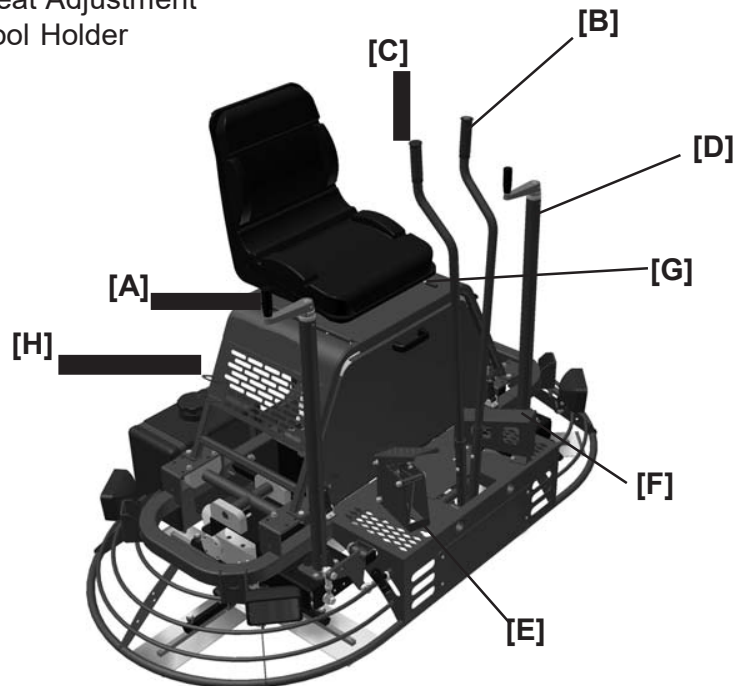

FIGURE 2.3.1
Operations Control Components

2.3, continued Operating Instructions

SECTION 2 OPERATIONS

- 2) With the operator in the seat, show him the functions of the joysticks **[B]** and **[C]** and how to start the machine. Refer to Figure 2.3.1.

A hard level concrete slab with water on the surface is an ideal place for an operator to practice with the machine. For practice pitch the blades up approximately 1/4 inch on the trailing edge. Start by making the machine hover in one spot and then practice driving the machine in a straight line and making 180 degree turns. Best control is achieved at full engine RPM.

CAUTION

After starting engine fully engage the throttle. This allows the engine to warm up quicker and also engages the centrifugal clutch. At this time the machine's rotors will begin turning.

CAUTION

DO NOT use excessive pressure on the joysticks. Excessive pressure does not increase the reaction time of the machine and can damage steering controls.

2.3.2 Stopping The Riding Trowel

To stop the trowel's movement, let go of the joysticks **[B]** and **[C]**. They will return to their neutral position. Also release pressure on the right foot pedal **[E]**.

CAUTION

If in need of an emergency stop, simply turning the key off or raising your left foot off the pedal will stop the engine from running.

2.3.3 Steering The Riding Trowel

A slight "feathering motion" forward and backward with the left hand joystick is required to move the machine in a straight path to the left or right while operating the right hand joystick. Refer to Figure 2.3.3..

Position	Action
1	Forward
2	Reverse
3	Rotate clockwise
4	Rotate counter clockwise
5	Left sideways
6	Right sideways

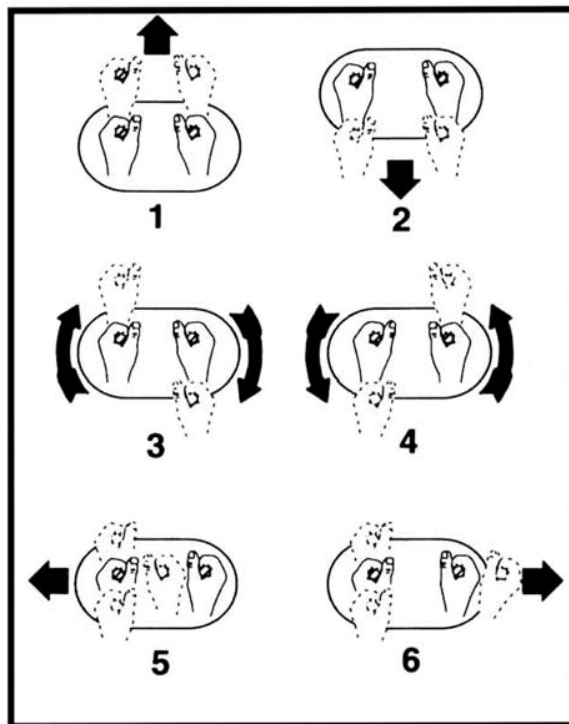

FIGURE 2.3.3
Steering Control Diagram

2.3, continued Operating Instructions

SECTION 2 OPERATIONS

2.3.4 Pitch Adjustment

Different pitch angles are needed as you work the different stages of the concrete. Refer to Figure 2.3.4 table below. When changing or setting pitch (angle of trowel blades), slow the machine down, set the desired degree of pitch on the left side of the machine and then adjust the right side to match.

To increase the pitch, turn the pitch control clockwise “a” use the pitch indicator “b” to adjust pitch equally on both right and left trowel blades.

	Working Conditions of Concrete	Suggested Working Pitch
	① Wet surface working stage	Flat (No Pitch)
	② Wet plastic working stage	Slight Pitch 5°
	③ Plastic working stage	Additional Pitch 10°
	④ Semi-hard working stage	Additional Pitch 15°
	⑤ Hard finishing stage (burnishing)	Maximum Pitch 20°

FIGURE 2.3.4
Pitch Adjustment

2.3.5 Steering Response Adjustment

There are three settings on this Riding Trowel for steering response. Some operators like a fast response to steering while others would rather have a slower response when pressure is applied to the operator joysticks. The following illustrations show each appropriate setting on the lower control arms to achieve the desired response.

NOTE: The faster setting makes the joysticks “tighter” to the operator and more force will be required to move the joysticks.

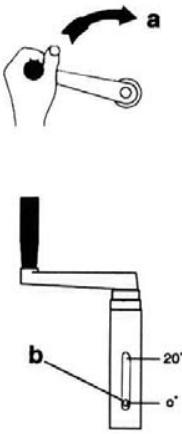
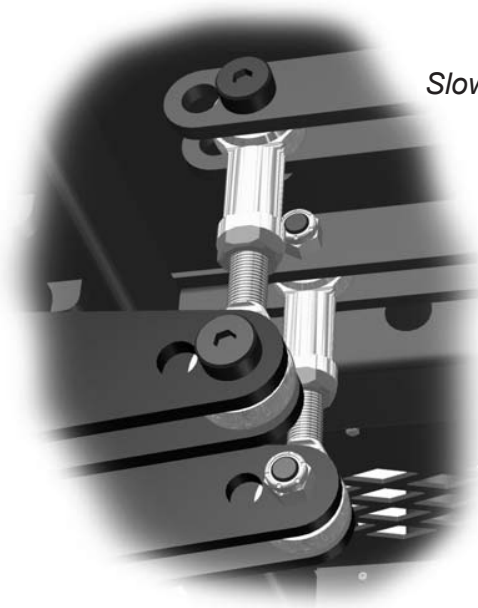

Slow Response Setting

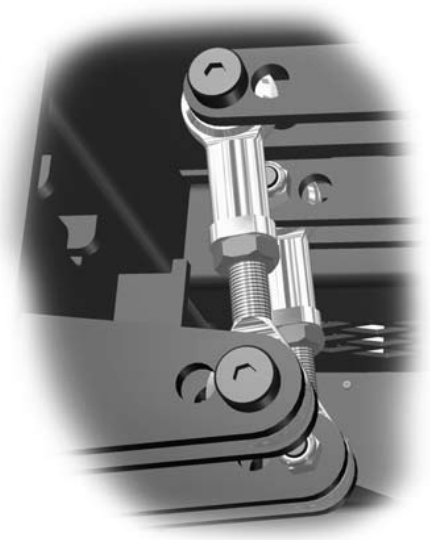

Normal Response Setting

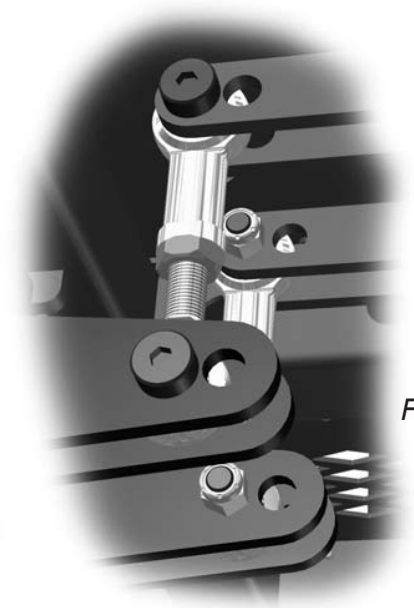

Fast Response Setting

Section 3
SERVICE

SECTION 3 SERVICE

3.1 Periodic Maintenance

3.1 Periodic Maintenance Schedule

The table below list basic trowel and engine maintenance. Refer to OEM engine manufacturer's Operation Manual for additional information on engine maintenance. A copy of the engine operator's manual was supplied with the machine when it was shipped. To service the engine pull the seat locking pin out and tilt seat back.

TABLE 3.1.1
CHECK LIST

ITEM	DAILY	EVERY 20 HRS	EVERY 50 HRS	EVERY 100 HRS	EVERY 300 HRS
Grease towel arms	/				
Check oil level in gearbox	/				
Check engine oil level	/				
Check & tighten external hardware	/				
Check drive belt for wear		/			
Check valve clearance					/
Change engine oil				/	
Replace engine oil filter				/	
Grease trowel gearbox					/
Replace spark plug					/

3.2 Trowel Gearbox

SECTION 3 SERVICE

3.2 Trowel Gearbox Maintenance

Check Oil levels in the gearbox daily (every 8 hours) Add oil if oil level is below the check sight glass.

- 1) To add oil tilt gearbox to the side and remove the fill plug. Add oil through hole opening. Replace fill plug after proper level has been achieved. Fill so that there is oil 1/2 way in the sight glass. Use Gearbox Oil PN 048299 only.
- 2) Each Gearbox has a grease fitting on top cover that must be greased (2 SHOTS ONLY) every 300 operating hours. Use only Mobilith SHC 220 Extended pressure grease.

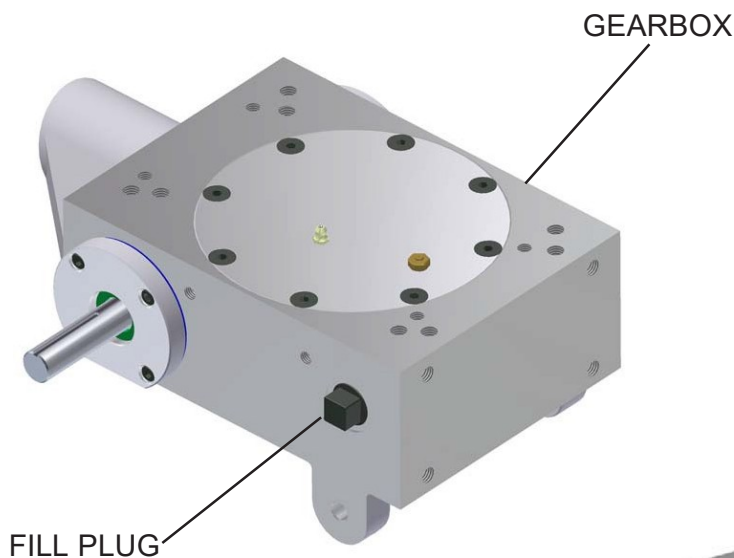

FIGURE 3.2.1
FILL PLUG LOCATION

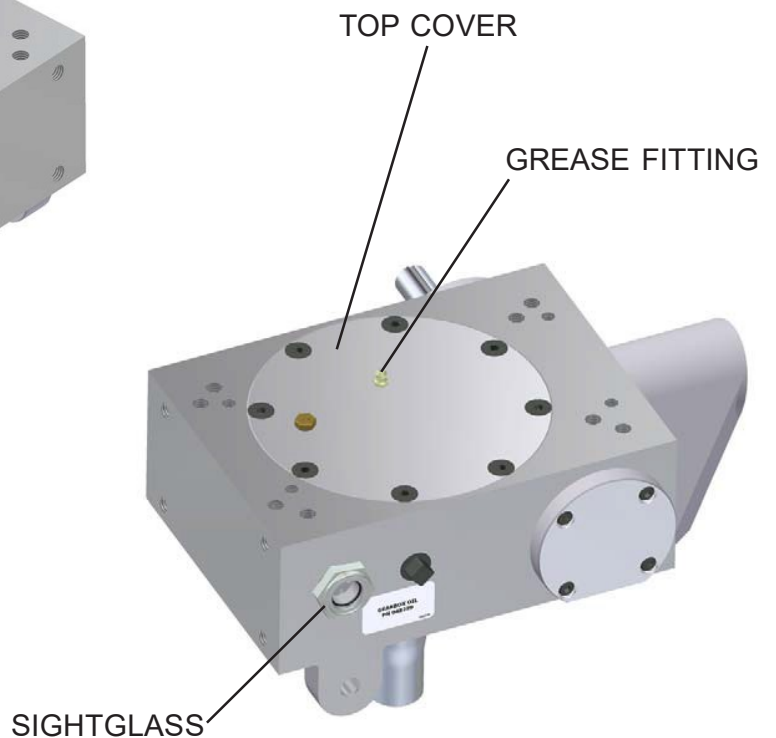

FIGURE 3.2.2
GREASE FITTING LOCATION

3.3.0 Drive Belt Maintenance



The drive belts MUST be free from oil and foreign contaminants to prolong life.

3.3.1 To Replace The Drive Belt:

- 1) Place the trowel on a flat, level surface with the blades pitched flat.
- 2) Disconnect the battery. Refer to Figure 3.3.1.
- 3) Remove the clutch cover. Refer to Figure 3.3.2.
- 5) Remove tap bolt to remove driver pulley.
- 6) Loosen the set screws in the flex u-joint.
- 7) Slide the u-joint apart so belt will slide through.
- 8) Replace belt using PN 051332.
- 9) Repeat steps 7 through 2 in reverse order.

3.3, continued Drive Belt

SECTION 3 SERVICE

MOVE POSITIVE
BATTERY CABLE

FIGURE 3.3.1
BATTERY DISCONNECT

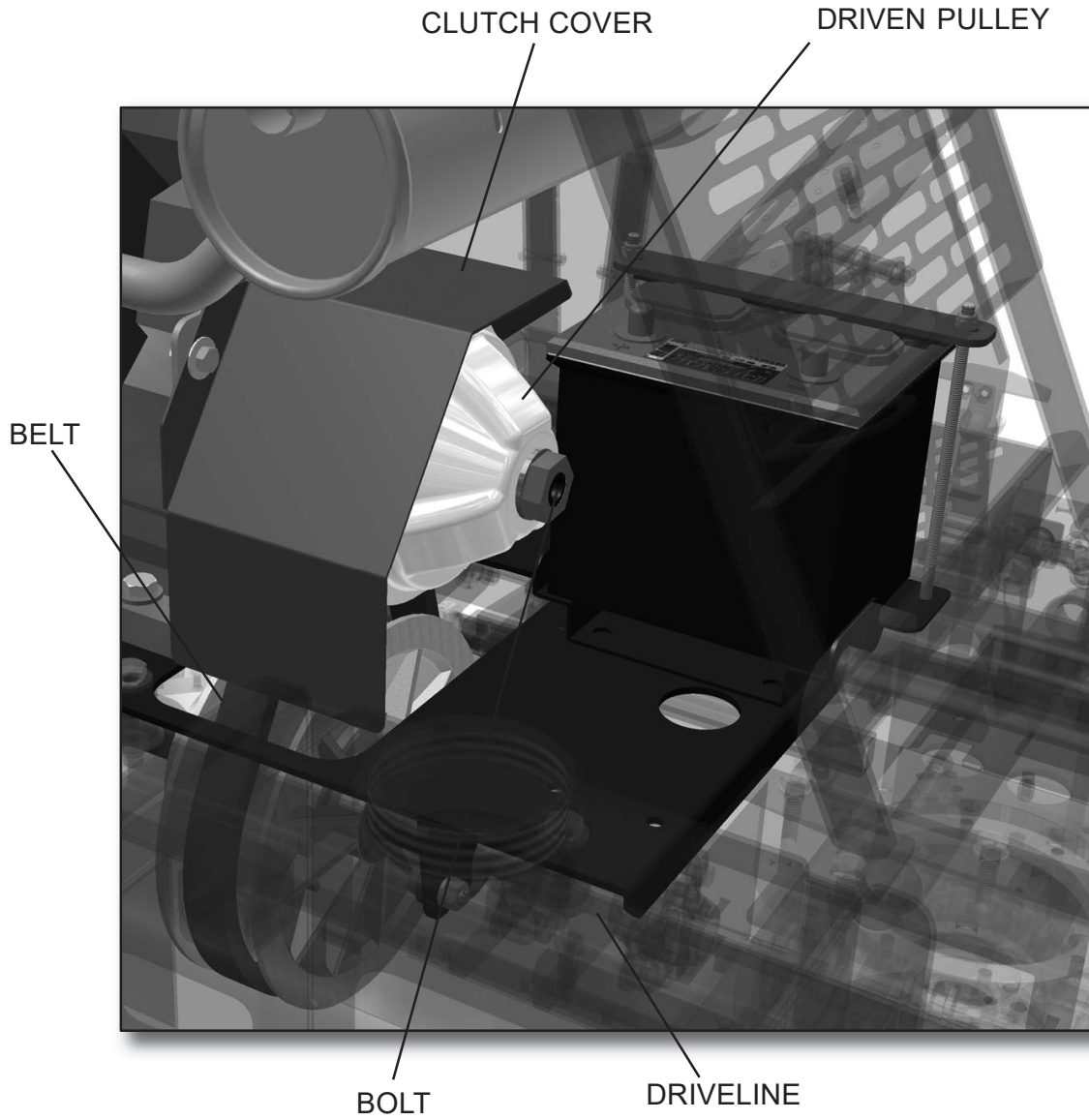
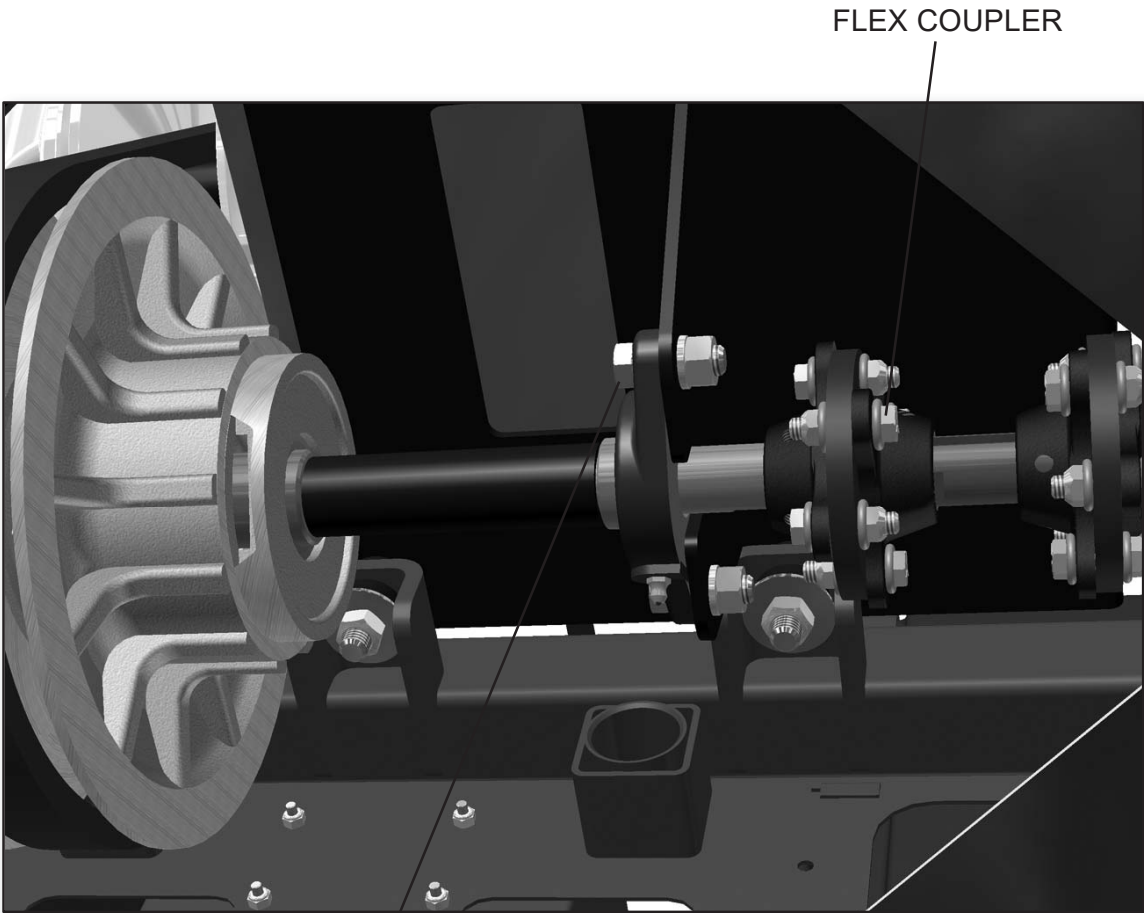

FIGURE 3.3.2
BELT REPLACEMENT

**3.3, continued
Drive Belt**

**SECTION 3
SERVICE**



BEARING MOUNT HARDWARE

FLEX COUPLER

**FIGURE 3.3.3
BELT REPLACEMENT**

3.4 **Control Lever Adjustment**

3.4 Control Lever Adjustment Procedure

Be sure that the trowel is on a level surface. The control levers should line up evenly. If levers appear out of adjustment they can be re-adjusted forward or backwards as follows:



Trowel must be placed on flat level surface that fully supports the blades on both rotors.

- 1) Remove bolts and nuts **[A]**.
- 2) Loosen jam nuts **[B]**.
- 3) Extend linkage to adjust control levers backward.
- 4) Shorten linkage to adjust linkage control levers forward.
- 5) After levers have been adjusted to the desired position, reassemble bolts and nuts **[A]** and tighten jam nuts **[B]**.

3.4, continued Control Lever Adjustment

SECTION 3 SERVICE

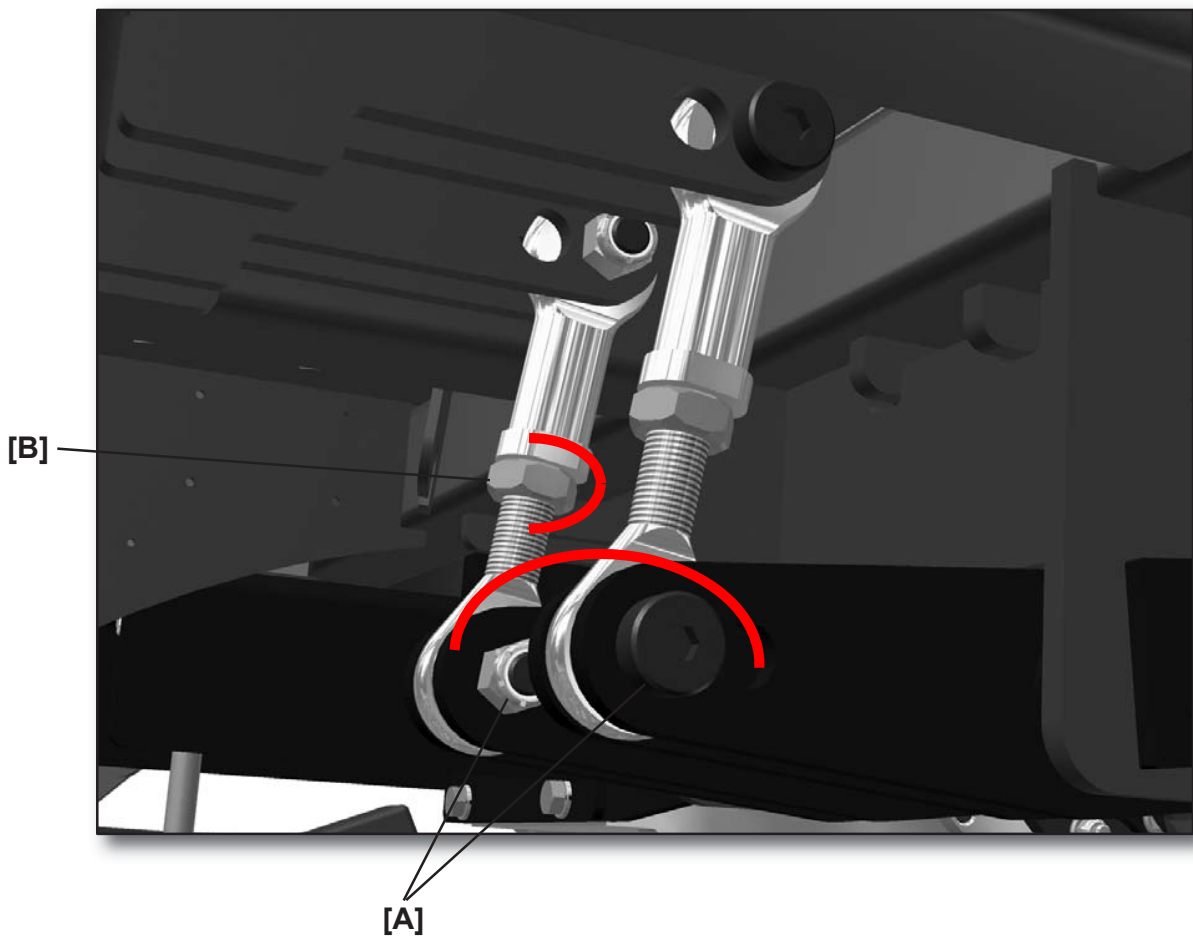

FIGURE 3.4.1
CONTROL LEVER ADJUSTMENT

3.5
Right Hand Control Lever Adjust

3.5 RH Control Lever Adjustment Right Or Left Procedure

The right hand lever should be set to the same angle as that of the left to form a "V". If levers become out of adjustment adjust the right hand lever as follows:

- 1) Remove jam nuts **[D]**.
- 2) Remove bolt **[C]**.
- 3) Extend linkage to move control levers to the right.
- 4) Shorten linkage to move control levers to the left.
- 5) After control lever has been adjusted to the desired position reassemble bolt **[C]** and tighten jam nuts **[D]**.

3.5, continued Right Hand Control Lever Adjust

SECTION 3 SERVICE

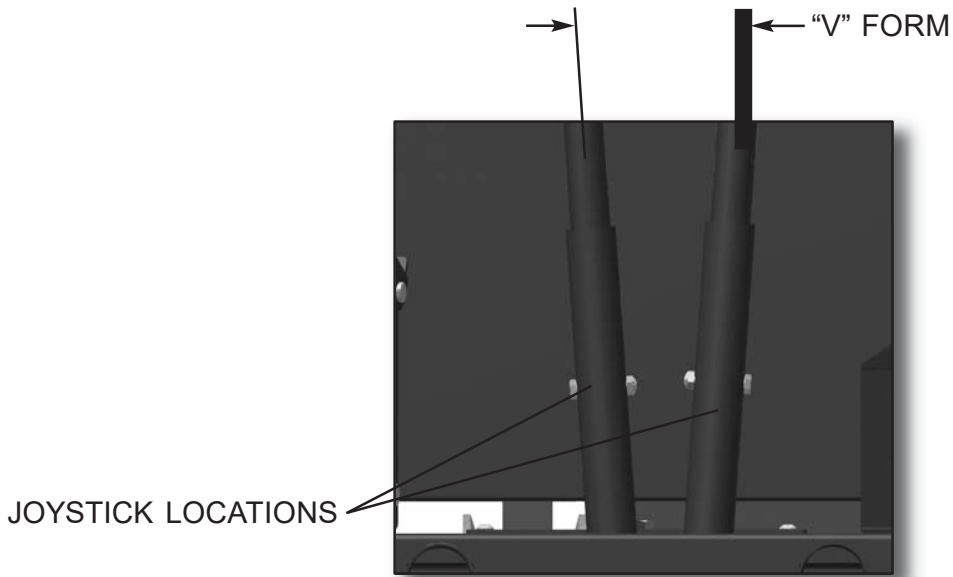

There should be a 10" gap at the top of the joysticks.

LOWER CONTROL ARM

FIGURE 3.5.1
“V” FORM ORIENTATION

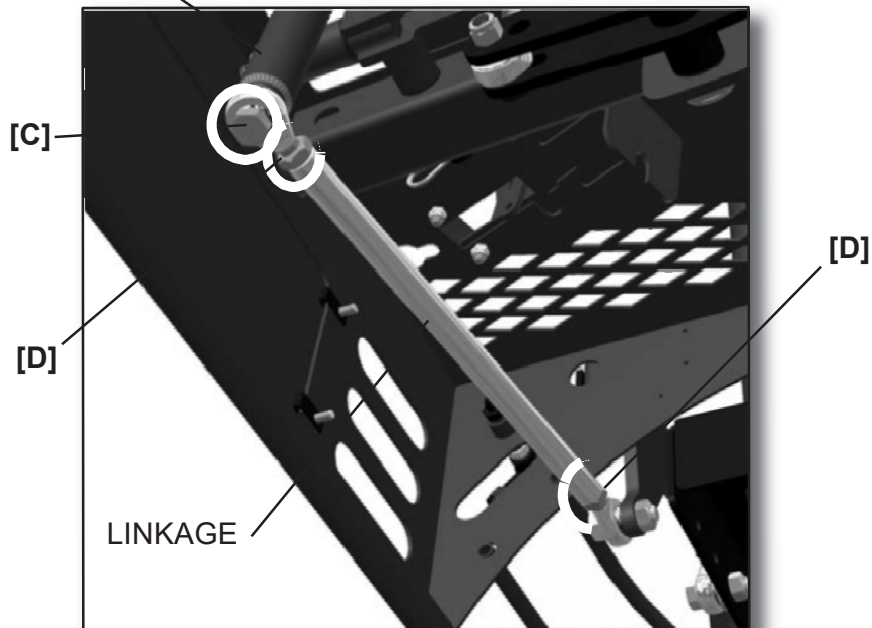

FIGURE 3.5.2
RIGHT HAND CONTROL ADJUSTMENT

3.6 **Lift Lever Adjustment**

3.6 Lift Lever Adjustment Procedure

Damage to and/or replacement of a trowel arm can change the adjustment of the lift lever. This can unbalance the trowel arms and cause the riding trowel to wobble during operation. To operate smoothly the lift lever on all trowel arms must be adjusted the same to ensure that the riding trowel is balanced correctly.

Adjusting the trowel arms is accomplished by using the optional trowel arm alignment jig PN 016863. The service manual that is included with the alignment jig describes in detail the steps to perform this procedure and to check the flatness and straightness of the trowel arms.

The steps below describe the general procedure to remove the trowel arms to be aligned.



Make sure that there is no pitch in the blades before attempting to remove a trowel arm.

- 1) Block up pressure plate **[A]** using a wooden block.
- 2) Remove stabilizer ring from spider assembly (only on available models).
- 3) Remove blades from trowel arms.
- 4) Loosen hex head cap screw **[B]** and remove it and the external star washer from the spider boss.
- 5) Remove trowel arms from spider boss with lift levers in place.
- 6) Clean flats on trowel arm before placing it in the trowel arm jig (PN 016863).
- 7) Perform the alignment procedures as outlined in the alignment jig service manual (PN 047427).
- 8) Re-attach trowel arm to spider boss and blades to trowel arms.
- 9) Tighten down hex head cap screw to secure trowel arm in place.
- 10) Reattach stabilizer ring (only on available models).

3.6, continued Lift Lever Adjustment

SECTION 3 SERVICE

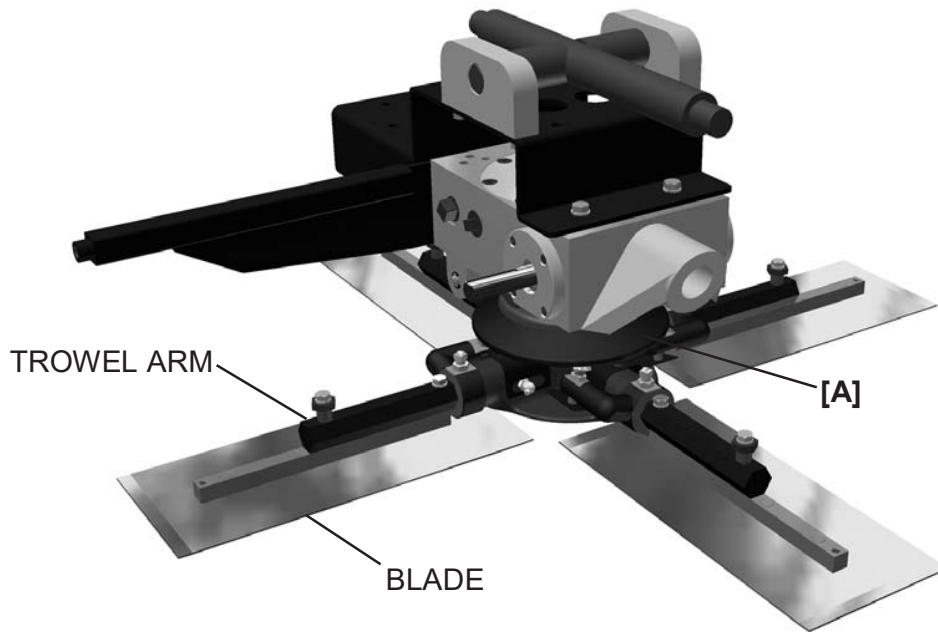

FIGURE 3.6.1
PRESSURE PLATE LOCATION

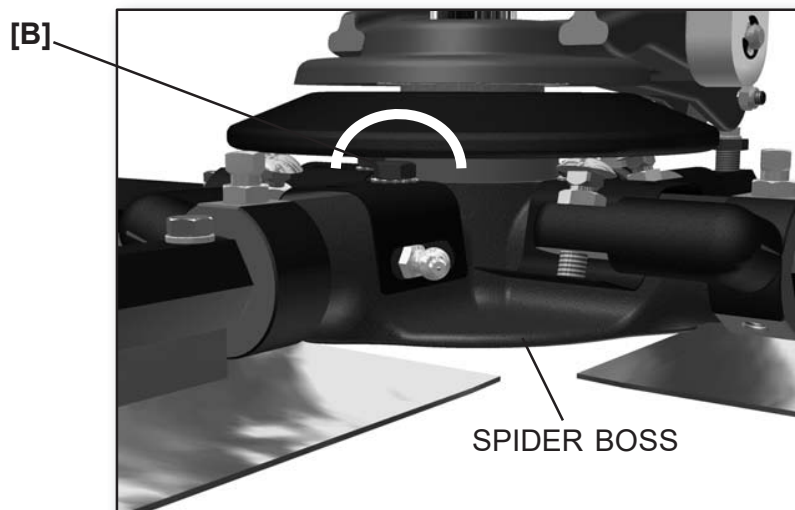

FIGURE 3.6.2
FASTENER HARDWARE REMOVAL

3.7 Transporting Trowel Procedures

Optional dolly jacks are available for short moves or to aid in servicing the trowel. Install dolly jacks as follows:

- 1) Inspect dolly jack for serviceability and damage.
- 2) Place riding trowel on firm level ground.



- 3) Tie steering levers **[I]** to frame to prevent them from tipping forward when trowel is being lifted. PACLITE assumes no liability if injury occurs and this step is eliminated during any trowel lifting procedures.
- 4) Insert the front dolly jack **[J]** fully into the holes in the mainframe of the riding trowel. The front dolly jacks are equipped with short lifting tubes while the rear dolly jacks have long lifting tubes.
- 5) Insert the rear dolly jack **[M]** with the long lifting tubes into the holes provided in the rear of the mainframe. The holes in the mainframe are located directly opposite the front holes.
- 6) Turn jack handles clockwise to lift trowels and counter-clockwise to lower trowel.

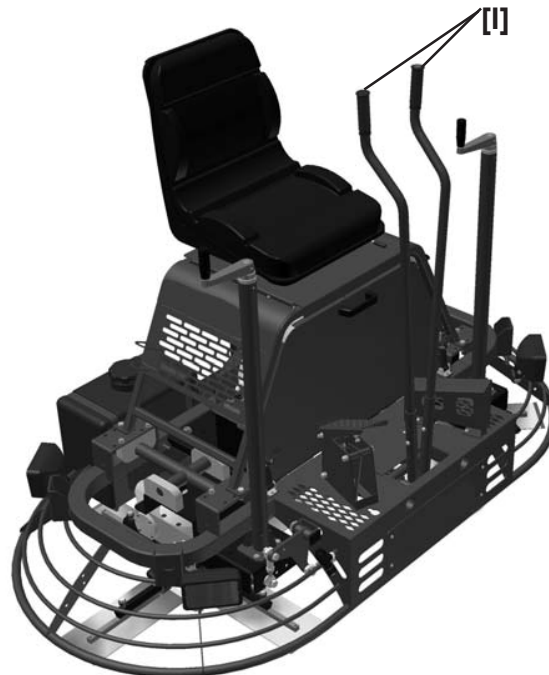

FIGURE 3.7.1
STEERING LEVER LOCATION

3.7, continued Transporting Trowel

SECTION 3 SERVICE

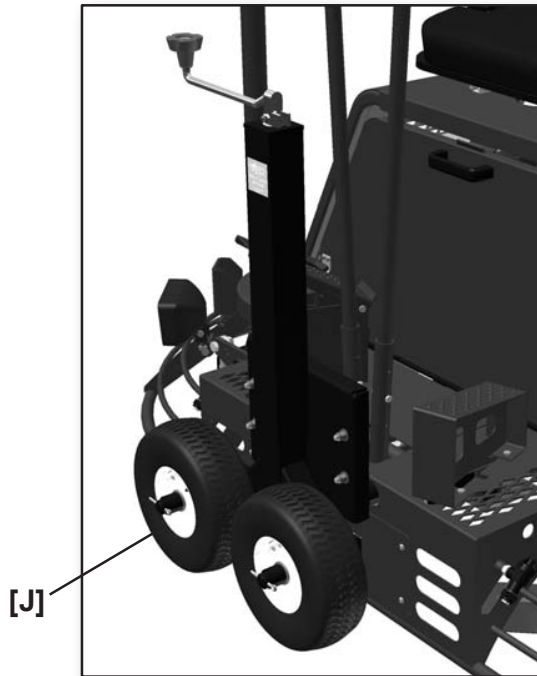

FIGURE 3.7.2
FRONT DOLLY JACK
LOCATION

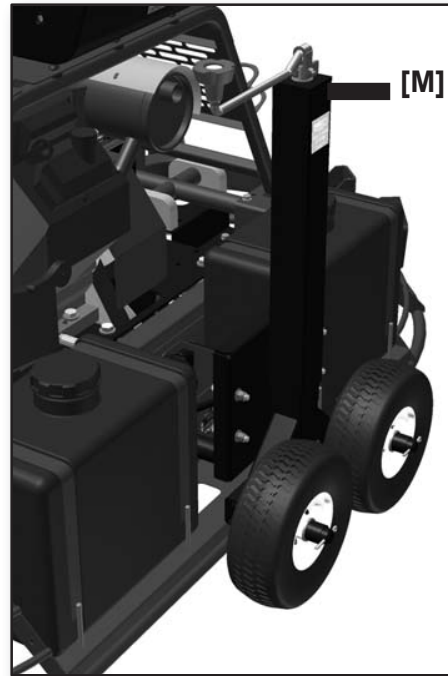

FIGURE 3.7.3
REAR DOLLY JACK
LOCATION

⚠ WARNING

The dolly jack lifting system is designed for short moves and to aid in servicing the trowel. It is not a substitute for a towing system or trailer. An optional lifting bridle [N] is available and recommended for lifting the trowel. Attach the bridle to each of the four lifting eyes [O] on the trowel. Refer to Figure 3.7.7.

⚠ WARNING

Secure steering levers to frame to prevent them from tipping forward when the trowel is being lifted.

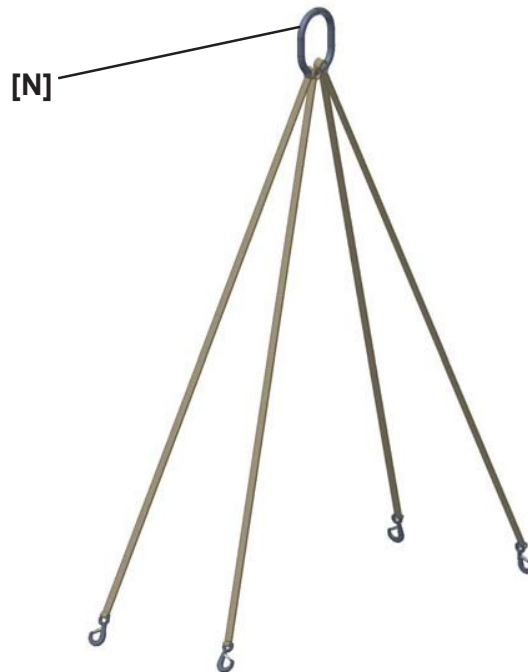
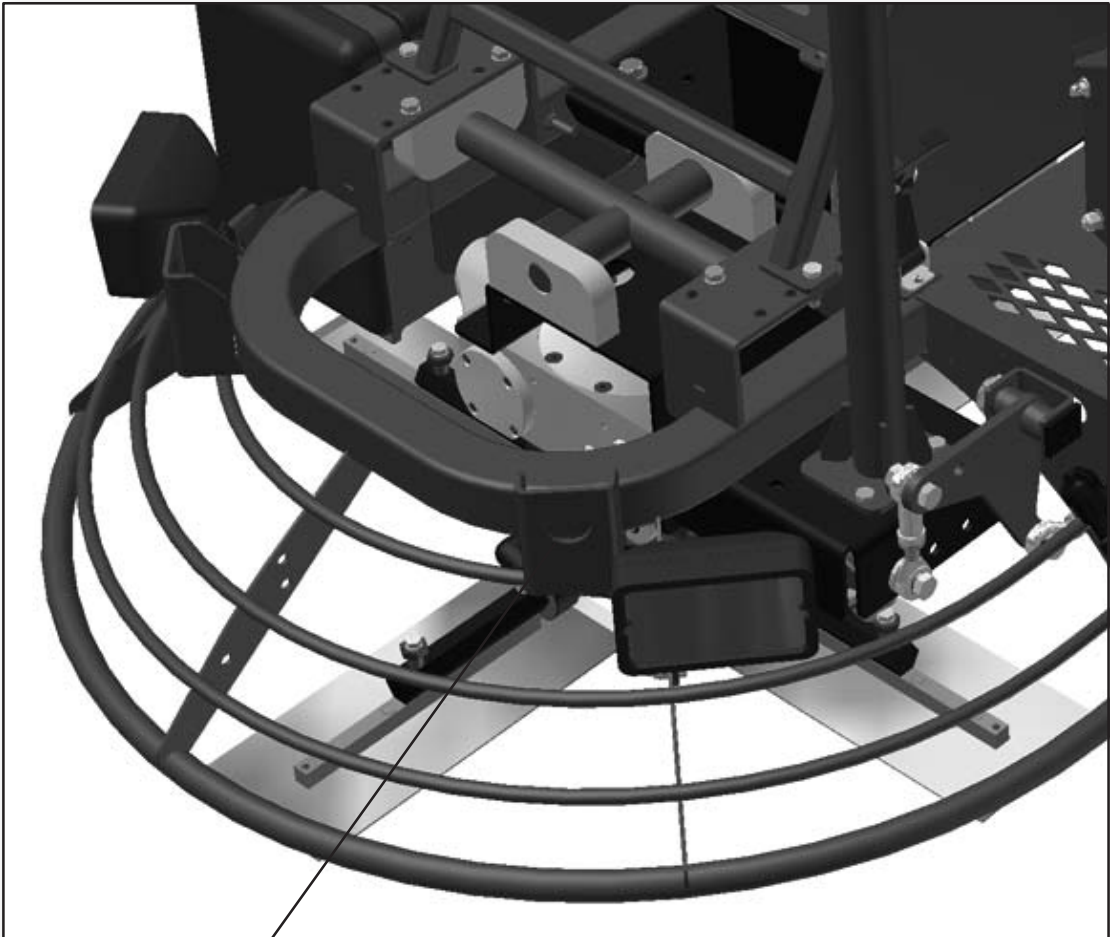

FIGURE 3.7.6
LIFTING BRIDLE

**3.7, continued
Transporting Trowel**

**SECTION 3
SERVICE**



[O]

FIGURE 3.7.7
LIFTING HOOK LOCATION

3.8 **Battery Jump Start**

3.9 Battery Jump Start Procedures

Occasionally it may be necessary to jump start a weak battery. If jump starting is necessary the following procedure is recommended to prevent starter damage, battery damage, and personal injury.



Jump starting a battery incorrectly can cause the battery to explode resulting in severe personal injury or death. Do not smoke or allow any ignition sources near the battery and do not start a frozen battery.



Electrical arcing can cause severe personal injury. Do not allow positive and negative cable ends to touch.

- 1) Use a battery of the same voltage (12V) as is used with your engine.
- 2) Attach one end of the positive booster cable (red) to the positive (+) terminal of the booster battery. Attach the other end to the terminal of your engine battery.
- 3) Attach one end of the negative booster cable (black) to the negative (-) terminal on the booster. Attach the other end of the negative cable to your engine battery.
- 4) Jump starting in any other manner may result in damage to the battery or the electrical system.



Over cranking the engine can cause starter damage. Allow 5 minutes for starter to cool if engaged for more than 15 seconds.



When using lights or high amperage draw accessories, idle the engine for a period of 20 minutes to bring the battery to charge state.

3.8, continued Battery Jump Start

SECTION 3 SERVICE

BATTERY

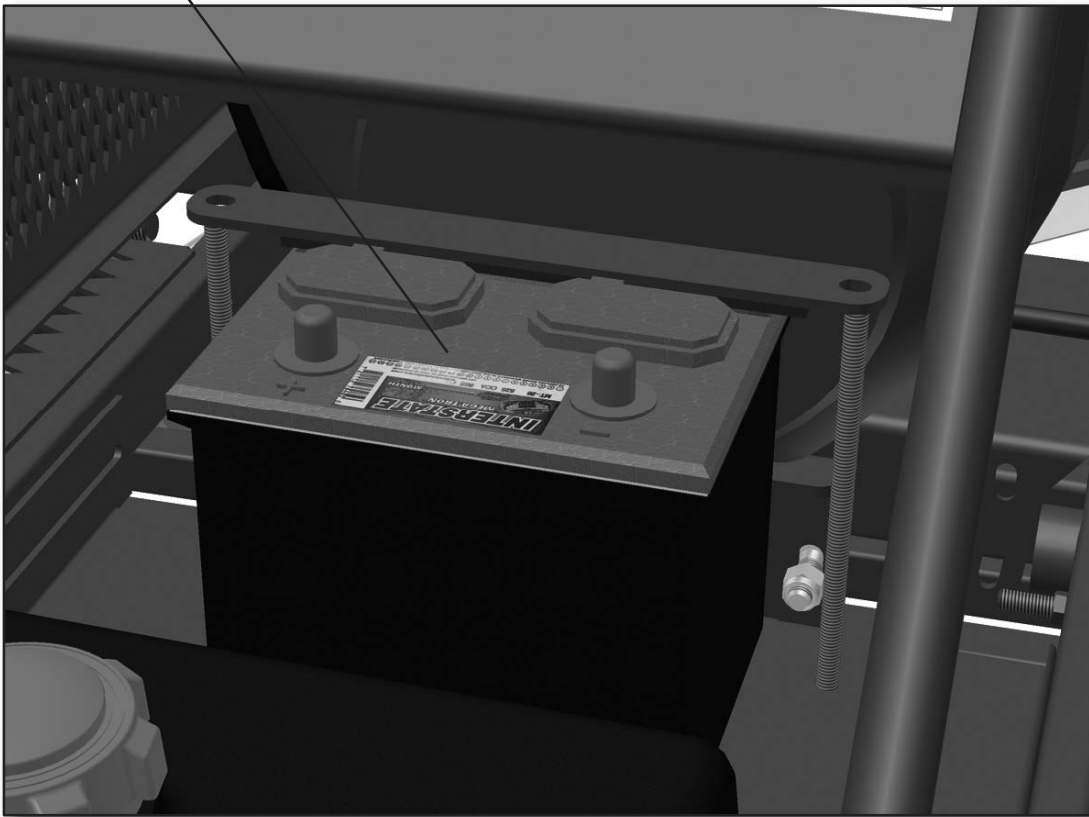

FIGURE 3.8.1
BATTERY LOCATION

Section 4
PARTS

SECTION 4 PARTS

Factory Service Information

This section contains the illustrated drawings and parts list for help in identifying and/or ordering replacement parts for your machine. Follow the instructions in the front section of this manual "Ordering Parts" when ordering replacement parts to insure prompt and accurate delivery.

The Right Hand (RH) and/or Left Hand (LH) orientations are defined from the operator's view of sitting on machine (SOM).

NOTE

All set screws have blue (LOC-TITE™) applied at the factory. If set screw is removed or loosened for any reason re-apply blue (LOC-TITE™).

NOTE

All grease fittings are capped with CAP PLUG GC-5 (PN 015692) to protect the fitting. If cap becomes missing or damaged replace it as soon as possible.

NOTE

Anti-Seize is applied at the factory to all drive line coupling, gear box main and counter shafts and pitch control threaded rod assemblies. If these parts are disassembled re-apply a light coat of a graphite based anti-seize.

We recommend PACLITE quality replacement parts, available from the PACLITE Customer Service Department or your nearest PACLITE Dealer.

Part numbers are subject to change without notice. Use part numbers listed in the applicable parts table when you place your order. If a part number changes, the PACLITE Customer Service Department or your nearest PACLITE dealer will have the latest part number for the replacement part.

Remember when you order replacement parts, you will need your model number and serial number. These are the numbers that you have recorded in the UNIT ID section of this manual. Please order replacement parts by the appropriate part number, not the key number.

This manual contains an illustrated parts list for help in ordering replacement parts for your machine. Follow the instructions below when ordering parts to insure prompt and accurate delivery:

1. All orders for service parts - include the serial number for the machine. Shipment will be delayed if this information is not available.
2. Include correct description and part number from the "PARTS" Section 4.
3. Specify exact shipping instructions, including the preferred routing and complete destination address.
4. **DO NOT** return parts to PACLITE without receiving written authorization from PACLITE. All authorized returns must be shipped pre-paid.
5. When placing an order, please contact the PACLITE Dealer nearest you.

NOTE

All information, specifications, and illustrations in this manual are subject to change without notice and are based on the latest information at the time of publication.

SECTION 4
PARTS

4.1 Illustration
Seat Frame Unit

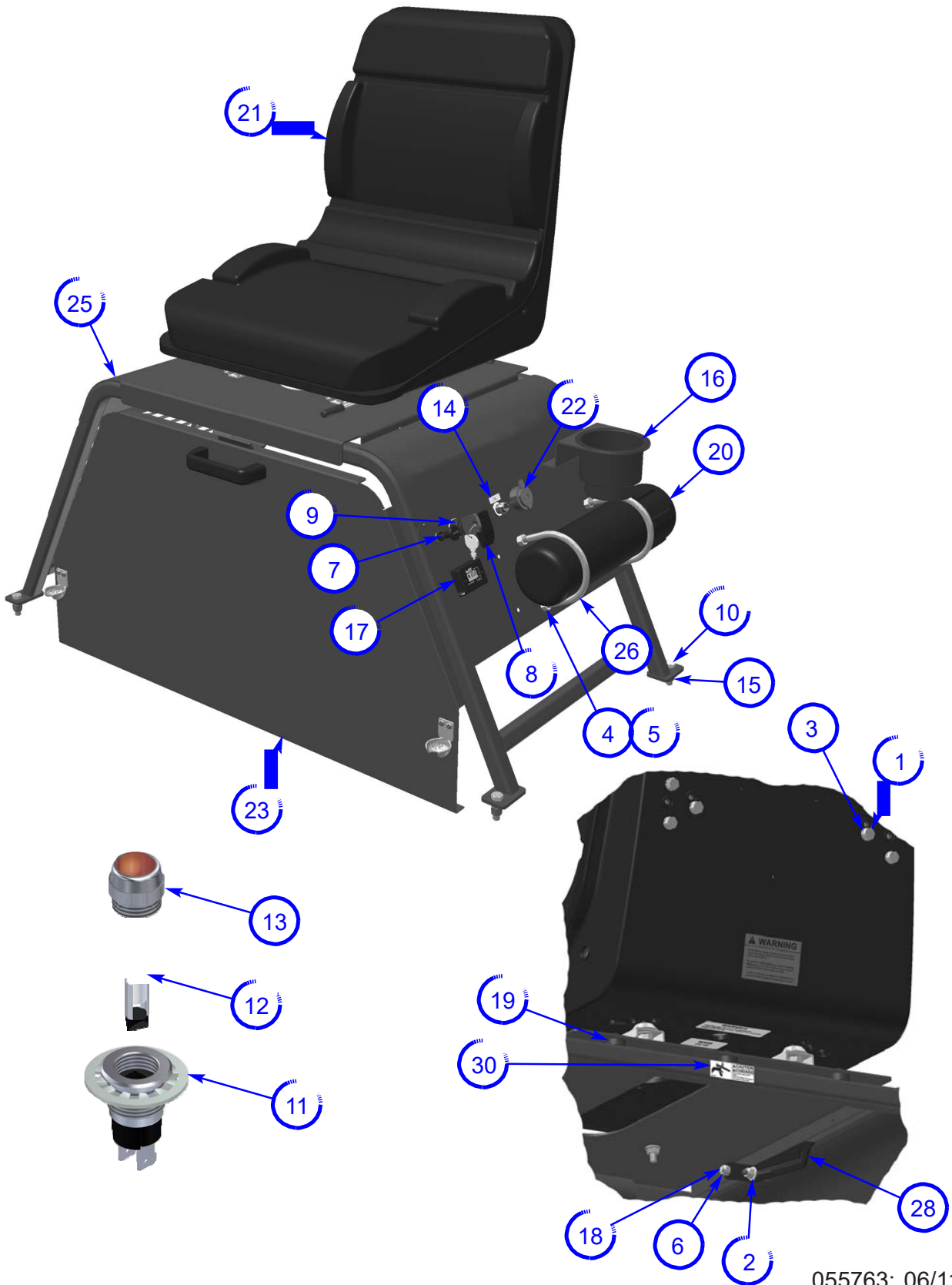

4.1 Parts List Seat Frame Unit

SECTION 4 PARTS

ITEM	PART #	DESCRIPTION	QTY
1	010019	FSTN, HHCS 5/16-18 X 3/4 GR 5	6
2	010081	FSTN, FW 1/4	3
3	010090	FSTN, LW 5/16	6
4	010102	FSTN, NUT HEX 3/8-16	4
5	010464	FSTN, NUT NYLOK 3/8-16	4
6	029671	FSTN, NUT HEX 1/4-20 NYLOC	2
7	029928	CHOKE CABLE ASSEMBLY	1
8	032125	SWITCH, ROCKER #91B2184	1
9	032148	KIT, KEY IGNITION SWITCH	1
10	032875	FSTN, HHCS 3/8-16 X 1-1/2 GR 8	4
11	034610	SOCKET, T-2 SLIDE BASE LAMP	1
12	034611	LAMP, T-2 SLIDE BASE #5	1
13	034614	LENS, T-2 LAMP RED JEWEL	1
14	036772	DECAL, "OIL"	1
15	040630	FSTN, 3/8-16 GR8 360 LOCKNUT	4
16	041537	CUP HOLDER	1
17	042036	METER, TACH/HOUR INDUCTIVE	1
18	042343	FSTN, SFBHCS 1/4"-20 x 3/4	1
19	047665	RUBBER BUMPER	3
20	048665	TUBE, MANUAL PACK PLASTIC 9000-14	1
21	049060	SEAT, WITH DRAIN	1
22	049588	FEMALE RECEPTICAL 12VDC	1
23	050061	FRONT PANEL ASSEMBLY	1
24			
25	053129	SEAT FRAME	1
26	053189	U-BOLT, 3 1/2" X 3/8-16	2
27	053206	WIRING HARNESS (NOT SHOWN)	1
28	053211	PROP F/ SEAT FRAME	1
29	053222	LIGHT HARNESS (NOT SHOWN)	1
30	028787	DECAL, CAUTION PINCH POINT	1

SECTION 4
PARTS

4.2 Illustration
Main Frame Unit

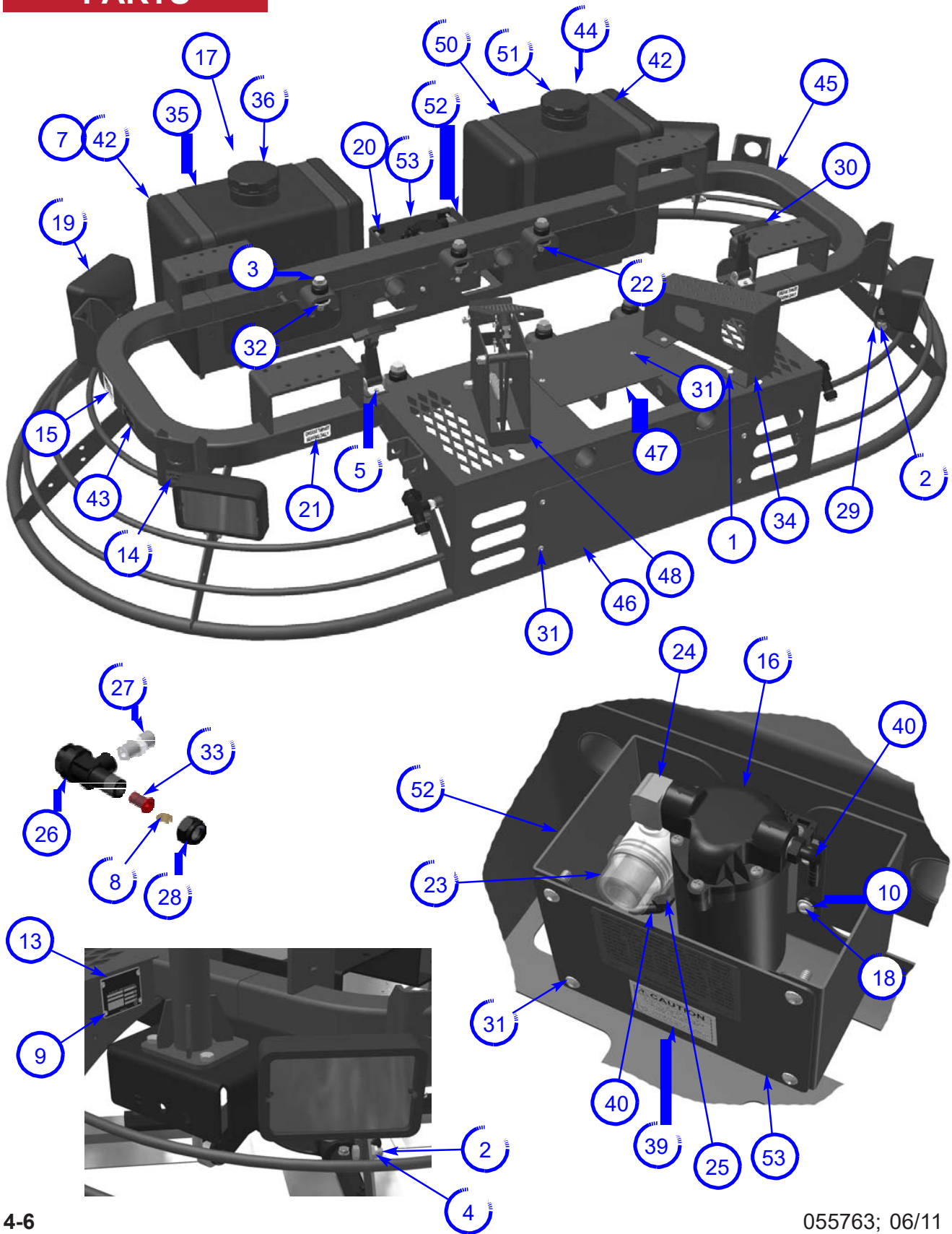

4.2 Parts List Main Frame Unit

SECTION 4 PARTS

ITEM	PART #	DESCRIPTION	QTY
1	010002	FSTN, HHCS 1/4-20 X 3/4	8
2	010036	FSTN, HHCS 3/8-16 X 1	8
3	010073	FSTN, HHCS 1/2-13 X 2-1/2 GR 5	6
4	010464	FSTN, NUT NYLOK 3/8-16	8
5	010568	SCR, 10-32 X 1/2 RND HD MACH	4
6	011490	FSTN, FW HARDENED 1/2	6
7	012612	FSTN, NUT HEX NYLOCK 5/16-18	4
8	012702	TIP, 80°x0.10 GPM BRASS SPRAY	2
9	012994	RIVET, 1/8x3/8 ALUM DOME	4
10	018072	WSHR, #10 Z STL SAE FLAT	4
11	029568	NUT, 10-32 NYLOCK HEX	4
12	029671	FSTN, NUT HEX 1/4-20 NYLOC	8
13	032096	DECAL, SERIAL NUMBER PLATE	1
14	032159	DECAL, LIFT HERE ONLY (SMALL)	4
15	032896	DECAL, MADE IN USA-FLAG	2
16	033735	PUMP, SPRAY SYSTEM	1
17	036767	DECAL, RETARDANT ONLY	1
18	036791	SCR, 10-32 X 3/8 SLTD RDH MACH	4
19	036881	LIGHT ASSEMBLY	4
20	039329	FSTN, CLIP TINNERMAN 1/4-20	8
21	039778	DECAL, GREASE THRUST BEARING DAILY	4
22	040208	FSTN, 1/2-13 STOVER NUT	6
23	040209	FILTER, RETARDANT SPRAY SYSTEM	1
24	040387	ELBOW, 3/8 BRASS 90° STREET	1
25	040388	FTG, 3/8X1/4 BRASS FM TO FM REDUCER	1
26	041604	VALVE, CHECK BODY	2
27	041606	PLASTIC 1/4 NPT CLOSE NIPPLE	2
28	041624	RETAINER, NYLON SPRAY TIP	2
29	042140	BRACKET, REAR LIGHT	4
30	042260	LATCH, FLEX DRAW LRG RUBBER	2
31	042343	FSTN, SFBHCS 1/4"-20 x 3/4	10
32	046744	MOUNT, VIB	6
33	047579	STRAINER, POLY 100 MESH	2
34	047646	FOOT REST	1
35	047700	TANK, 6 GALLON PLASTIC BLACK	1
36	047701	CAP, 3-1/2" VENTED BLACK	1
37	047702	FTG, 'L' FUEL 1/4" NIPPLE 90 DEG	1
38	047703	BUSHING, 6 GAL PLASTIC TANK	1
39	047878	DECAL, BELT CONTAMINATION CAUT	1
40	047933	ELBOW, 1/4 PUSHLOK x 1/4 NPT PLASTIC	4
41			
42	048921	STRAP, TANK	4
43			
44	050147	DECAL, GASOLINE BEST PERFORMANCE	1
45	053116	MAIN FRAME WMNT	1
46	055644	FRONT COVER PLATE	1
47	053138	COVER PLATE	1
48	053188	ASSY, THROTTLE PEDAL	1
49	053197	BRKT, THROTTLE CABLE	1
50	053200	TANK, 6 GALLON GAS, EPA	1
51	053213	CAP, GASOLINE, EPA	1
52	053323	BRKT F/ PUMP COVER	2
53	053324	PUMP COVER	1

SECTION 4
PARTS

4.3 Illustration
Steering System

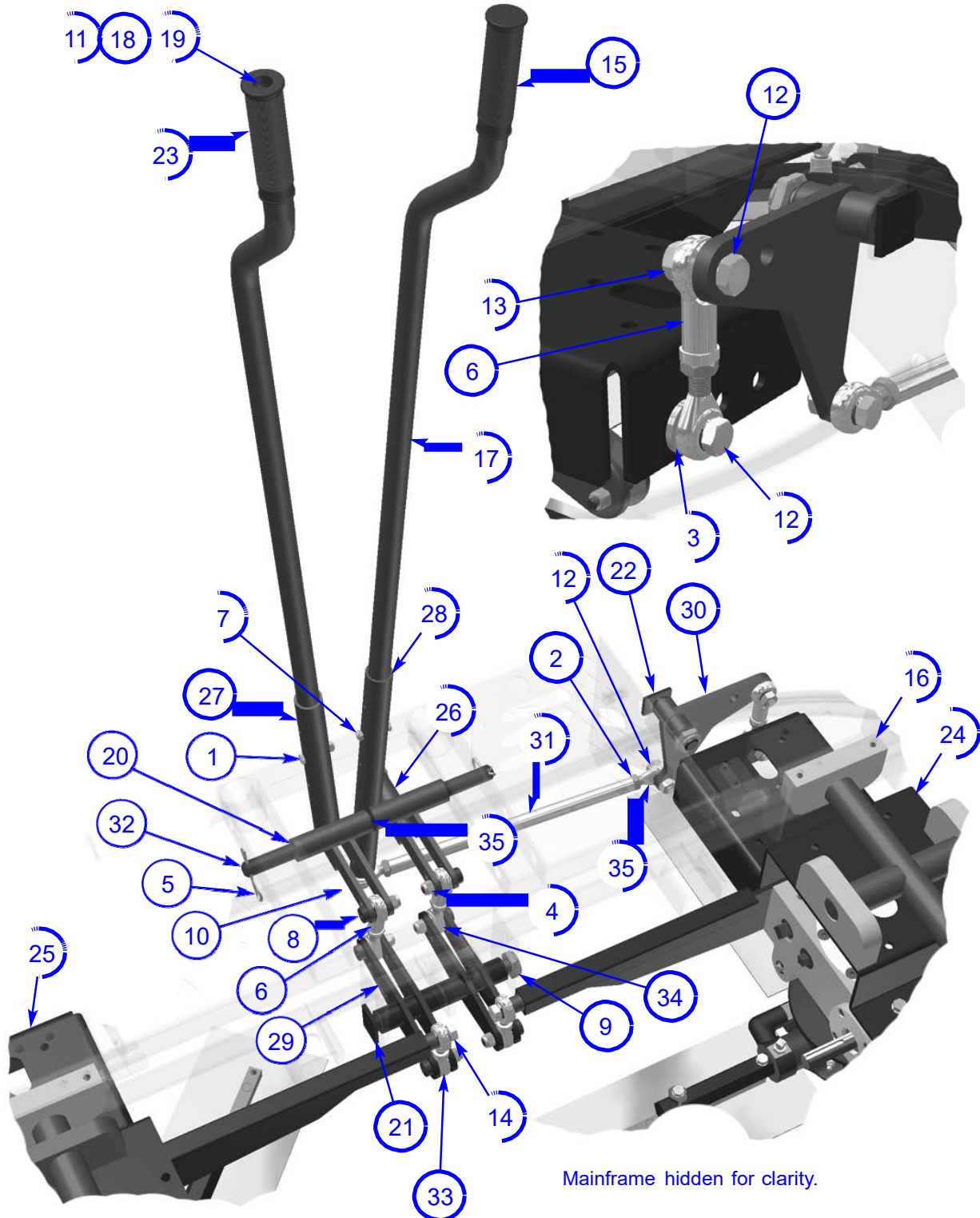

4.3 Parts List Steering System

SECTION 4 PARTS

ITEM	PART #	DESCRIPTION	QTY
1	010005	FSTN, HHCS 1/4-20 X 1-1/2 GR 8	2
2	010051	FSTN, NUT 1/2-20 JAM HEX	5
3	010085	FSTN, FW 1/2	2
4	010464	FSTN, NUT NYLOK 3/8-16	7
5	010711	CLIP, .125x2-9/16 HITCH PIN	2
6	019900	ROD, END FEMALE 1/2"	3
7	020542	FSTN, NUT STOVER LOCK 1/4-20	2
8	026267	FSTN, SHLDR 1/2" X 1" LONG	6
9	026447	NUT, 3/4-10 SELFLOCK THIN HEX	3
10	037140	BOLT, 1/2-20x1-1/2 GR 5 HHC	1
11	037481	WIRE, 18 GA. 2 CONDUCTOR	6'
12	037798	FSTN, HHCS 1/2-13 X 1 1/2 GR8	3
13	040208	FSTN, 1/2-13 STOVER NUT	3
14	047480	BOLT, 1/2-20x1-1/4 YZ GR 8 HEXHD CAP	2
15	048354	GRIP, SAT 3 Ø1 BLACK HANDLE	1
16	048561	BEARING ASSEMBLY F/ ROTOR MOUNT	4
17	048896	JOYSTICK, STEERING	2
18	048909	SWITCH, PUSH BUTTON	1
19	048910	BRG, Ø5/8 NYL FLNG SLEEVE	1
20	048929	BEARING, Ø3/4 ID PLASTIC FLANGE	12
21	048969	WELDMENT, STEERING SHAFT	1
22	048970	WELDMENT, FULCRUM SHAFT	1
23	049245	GRIP, MODIFIED HANDLE	1
24	053102	ROTOR ASSEMBLY, RH	1
25	053103	ROTOR ASSEMBLY, LH	1
26	053111	LEVER, STEERING, RH	1
27	053114	LEVER, STEERING, LH	1
28	053115	STEERING TUBE WMNT, RH	1
29	053120	PIVOT ARM F/ STEERING	2
30	053124	STEERING LEVER WMNT	1
31	053126	SHAFT, 18" LONG STEERING LINKAGE	1
32	053179	PIVOT ROD	1
33	053183	STEERING LINK, SHORT	2
34	221408	ROD, END MALE 1/2"	5
35	048928	SHIM, STEEL F/ FULCRUM	2

SECTION 4
PARTS

4.4 Illustration
Spray System

Mainframe hidden for clarity.

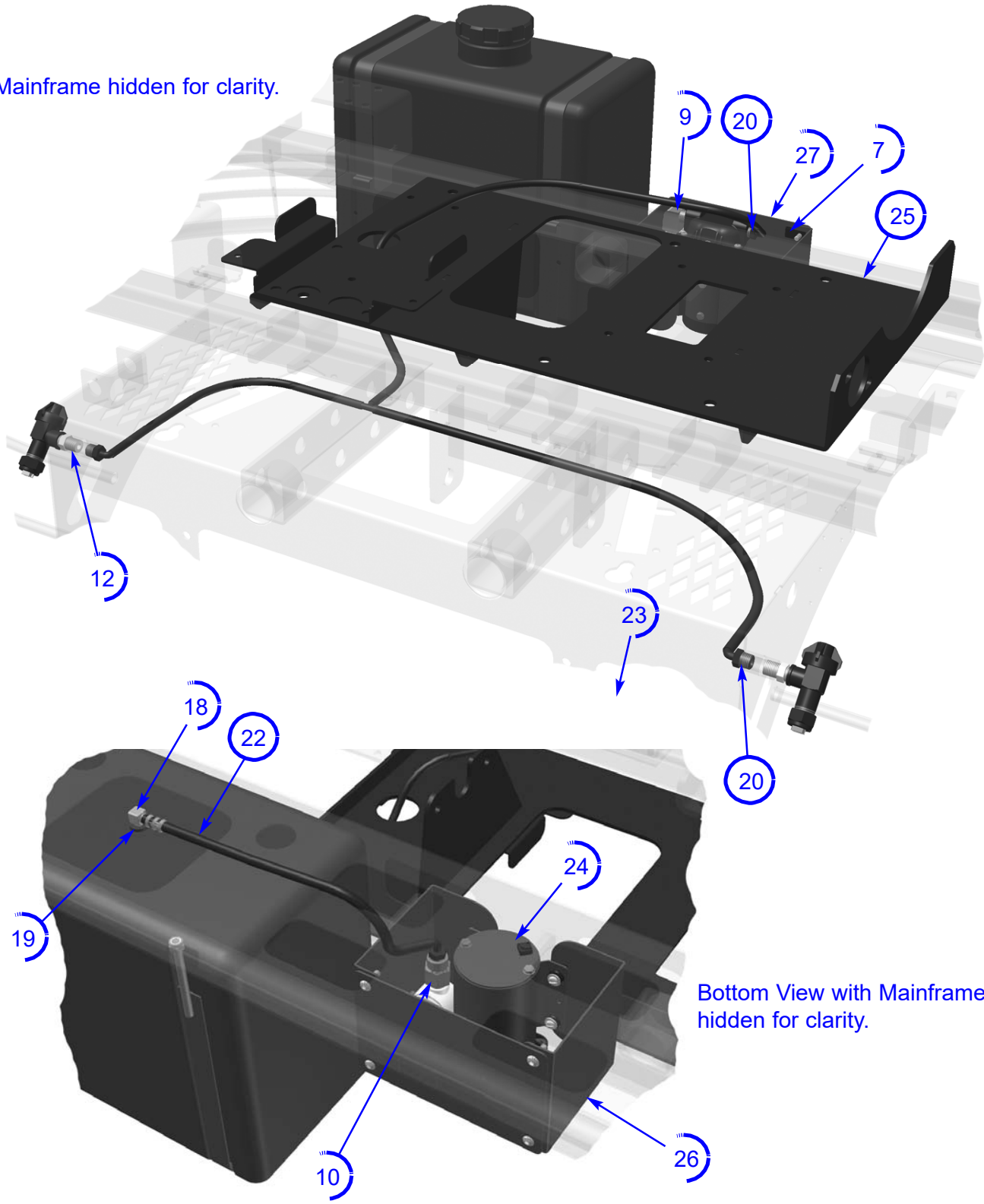

Bottom View with Mainframe hidden for clarity.

4.4 Parts List Spray System

SECTION 4 PARTS

ITEM	PART #	DESCRIPTION	QTY
1	012612	FSTN, NUT HEX NYLOCK 5/16-18	2
2	012702	TIP, 80°x0.10 GPM BRASS SPRAY	2
3	018072	WSHR, #10 Z STL SAE FLAT	4
4	029568	NUT, 10-32 NYLOCK HEX	4
5	033735	PUMP, SPRAY SYSTEM	1
6	036791	SCR, 10-32 X 3/8 SLTD RDH MACH	4
7	039329	FSTN, CLIP TINNERMAN 1/4-20	4
8	040209	FILTER, RETARDANT SPRAY SYSTEM	1
9	040387	ELBOW, 3/8 BRASS 90° STREET	1
10	040388	FTG, 3/8X1/4 BRASS FM TO FM REDUCER	1
11	041604	VALVE, CHECK BODY	2
12	041606	PLASTIC 1/4 NPT CLOSE NIPPLE	2
13	041624	RETAINER, NYLON SPRAY TIP	2
14	042343	FSTN, SFBHCS 1/4"-20 x 3/4	4
15	047579	STRAINER, POLY 100 MESH	2
16	047700	TANK, 6 GALLON PLASTIC BLACK	1
17	047701	CAP, 3-1/2" VENTED BLACK	1
18	047702	FTG, 'L' FUEL 1/4" NIPPLE 90 DEG	1
19	047703	BUSHING, 6 GAL PLASTIC TANK	1
20	047933	ELBOW, 1/4 PUSHLOK x 1/4 NPT PLASTIC	4
21			
22	048246	HOSE, 3/8" WATER LINE	1
23	048652	TEE, PLASTIC 1/4 x 1/4 x 1/4	1
24	048921	STRAP, TANK	2
25	050069	ENGINE PLATE WELDMENT	1
26	053323	BRKT F/ PUMP COVER	2
27	053324	PUMP COVER	1

SECTION 4
PARTS

4.5 Illustration
Pitch Control Assembly

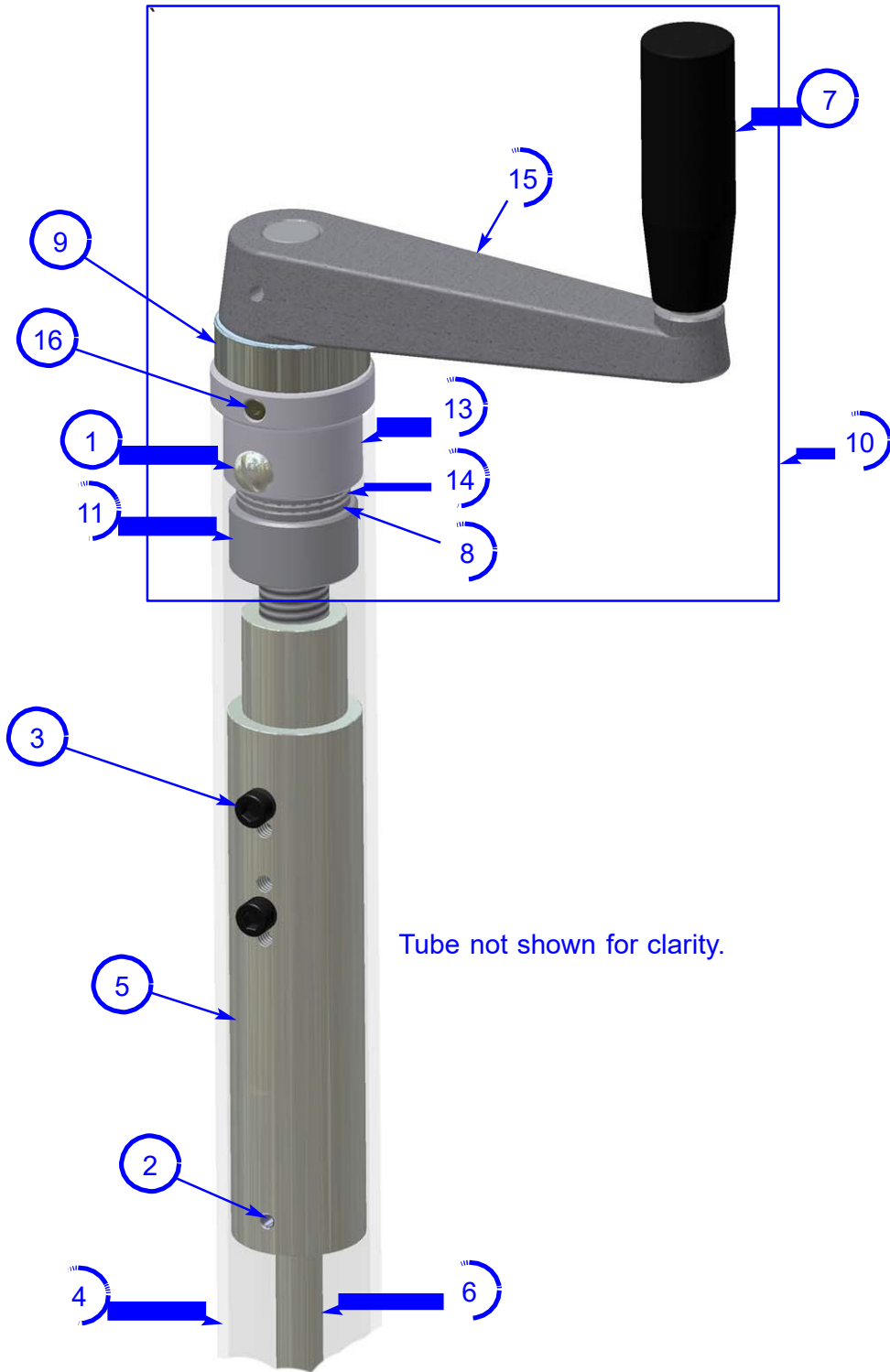

4.5 Parts List Pitch Control Assembly

SECTION 4 PARTS

ITEM	PART #	DESCRIPTION	QTY
	032370	ASSY, PITCH CONTROL	
1	015410	SCREW, 1/4-20x3/8 RND HD MACH	2
2	015747	PIN, 3/16x1-3/8 ROLL	1
3	015768	SCREW, 1/4-20x1/4 SCKT HD CAP	2
4	026420	TUBE, PRO PITCH CONTROL	1
5	029812	BUSHING, SLIDE PITCH CONTROL	1
6	029822	SHAFT, PITCH CONTROL	1
7	032115	KNOB, PITCH CONTROL HANDLE	1
8	012710	RACE, BEARING THRUST	2
9	015742	BEARING, FINE PITCH CONTROL	1
10	032157	ASSY, HANDLE	1
11	032191	STOP, PITCH CONTROL HANDLE	1
12	036797	PLUNGER, 1/4-20 BALL	2
13	036914	BUSHING, CABLE ASSY	1
14	100340	BEARING, NAT-1220 THRUST	1
15	026541	CRANK HANDLE & SCREW SHAFT ASY	1
16	012869	FSTN, SHSS 1/4-20 X 3/8	2

SECTION 4
PARTS

4.6 Illustration
Engine System - GX690 Honda

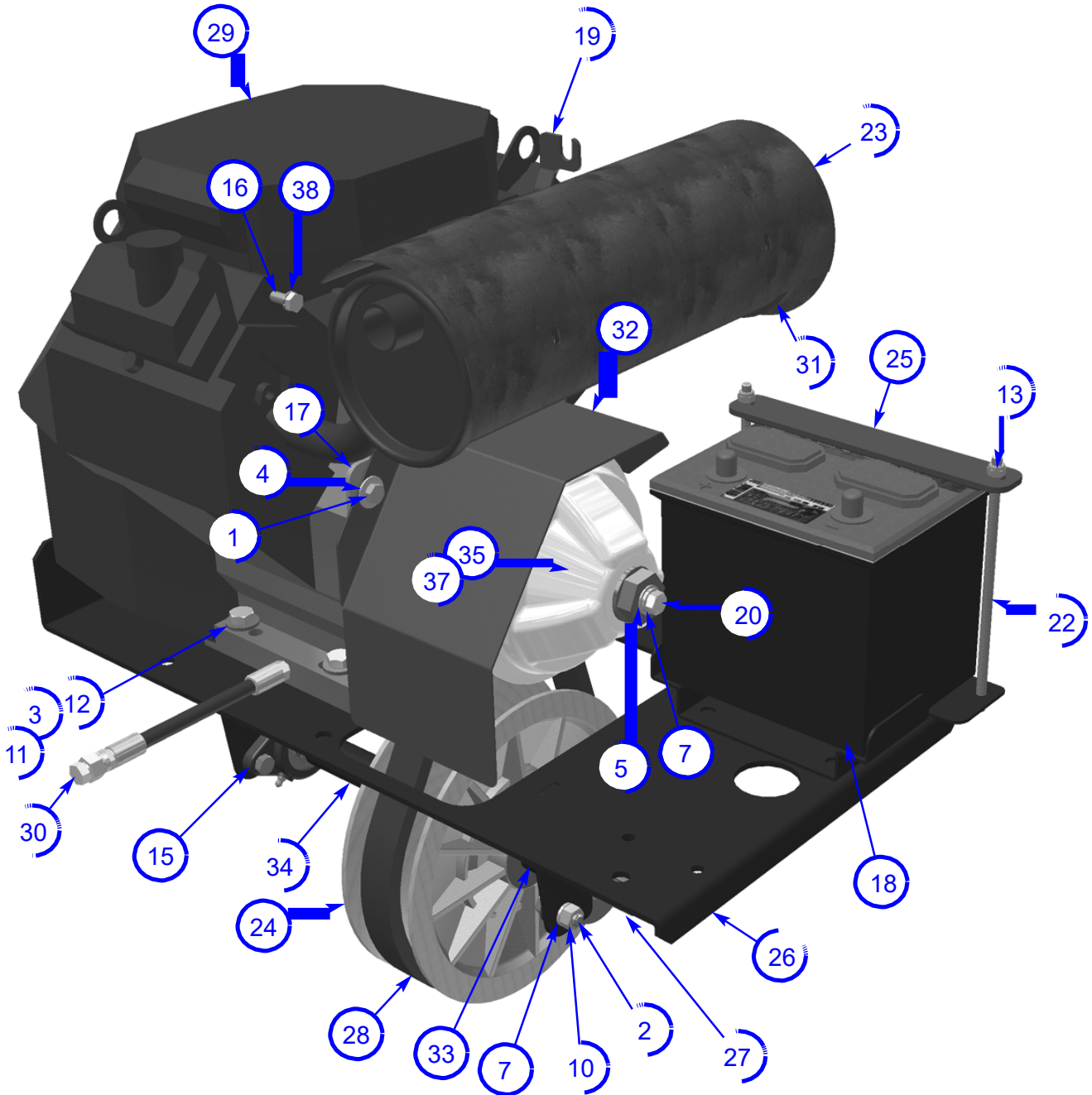

4.6 Parts List Engine System - GX690 Honda

SECTION 4 PARTS

ITEM	PART #	DESCRIPTION	QTY
1	010035	FSTN, HHCS 3/8-16 X 3/4	2
2	010053	FSTN, HHCS 7/16-14 X 1-1/4	4
3	010072	FSTN, HHCS 1/2-13 X 2-1/4 GR 5	4
4	010083	FSTN, FW 3/8	2
5	010084	FSTN, FW 7/16	1
6	010091	FSTN, LW 3/8	2
7	010092	FSTN, LW 7/16	7
8	010096	FSTN, Ø7/16 ID Y-ZINC HRDND FLAT	1
9	010102	FSTN, NUT HEX 3/8-16	2
10	010104	FSTN, HEX NUT 7/16-14	4
11	011238	FSTN, NUT HEX NYLOK 1/2-13	4
12	011490	FSTN, FW HARDENED 1/2	4
13	012612	FSTN, NUT HEX NYLOCK 5/16-18	4
14	017898	FSTN, HHCS 7/16-20 X 1-1/2 GR8	1
15	019334	BEARING, Ø1 ID SCJT-1 FLANGE	2
16	032863	FSTN, HHCS M8 x 1.25 x 20MM	2
17	033661	PLATE, BELT GURD BKT.	1
18	037771	BATTERY, 12 V GRAY 655CA	1
19	040224	BRKT, HONDA SERIES #2 THROTTLE CABLE	1
20	042280	SCR, 7/16-20x4-1/2 YZ GR 8 HHC	1
21	047273	CUSHION F/ BATTERY STRAP	1
22	047715	ROD, 5/16-18 BATTERY RETAINER 8-5/8"	2
23	048349	GUARD, HO VER 2 MUFFLER	1
24	048919	PULLEY, DRIVEN	1
25	048932	BAR, BATTERY HOLD DOWN	1
26	050069	ENGINE PLATE WELDMENT	1
27	050070	SHAFT, DRIVE 17 1/2 F/LOCK BEARING	1
28	051332	BELT, CVT Retro Fit Hoffco/CV Tech	1
29	051978	ENGINE, HONDA GX690-RTDW	1
30	051980	HOSE, DRAIN F/ HONDA GX690	1
31	051981	MUFFLER, HONDA GX690	1
32	053136	CLUTCH COVER	1
33	053193	SPACER, BEARING, 1 3/8"	1
34	053194	SPACER, BEARING, 4 3/4"	1
35	053198	PULLEY, 20:1 DRIVER	1
36	053207	FSTN, HHCS 7/16-14 X 1-1/4	2
37	053210	KEY, 3/16 X 1/4 X 2	1
38	020604	CLIP, WIRE HOLDER INS. 3/8 BLT (NOT SHOWN)	5
39	038070	CABLE, GROUND BRAIDED (NOT SHOWN)	1
40	048684	CABLE, 4 AWG 36 LG POS BATTERY (NOT SHOWN)	1
41	053216	CABLE, 4 AWG 17" LG NEG. BATTERY (NOT SHOWN)	1

SECTION 4
PARTS

4.7 Illustration
Driveline System

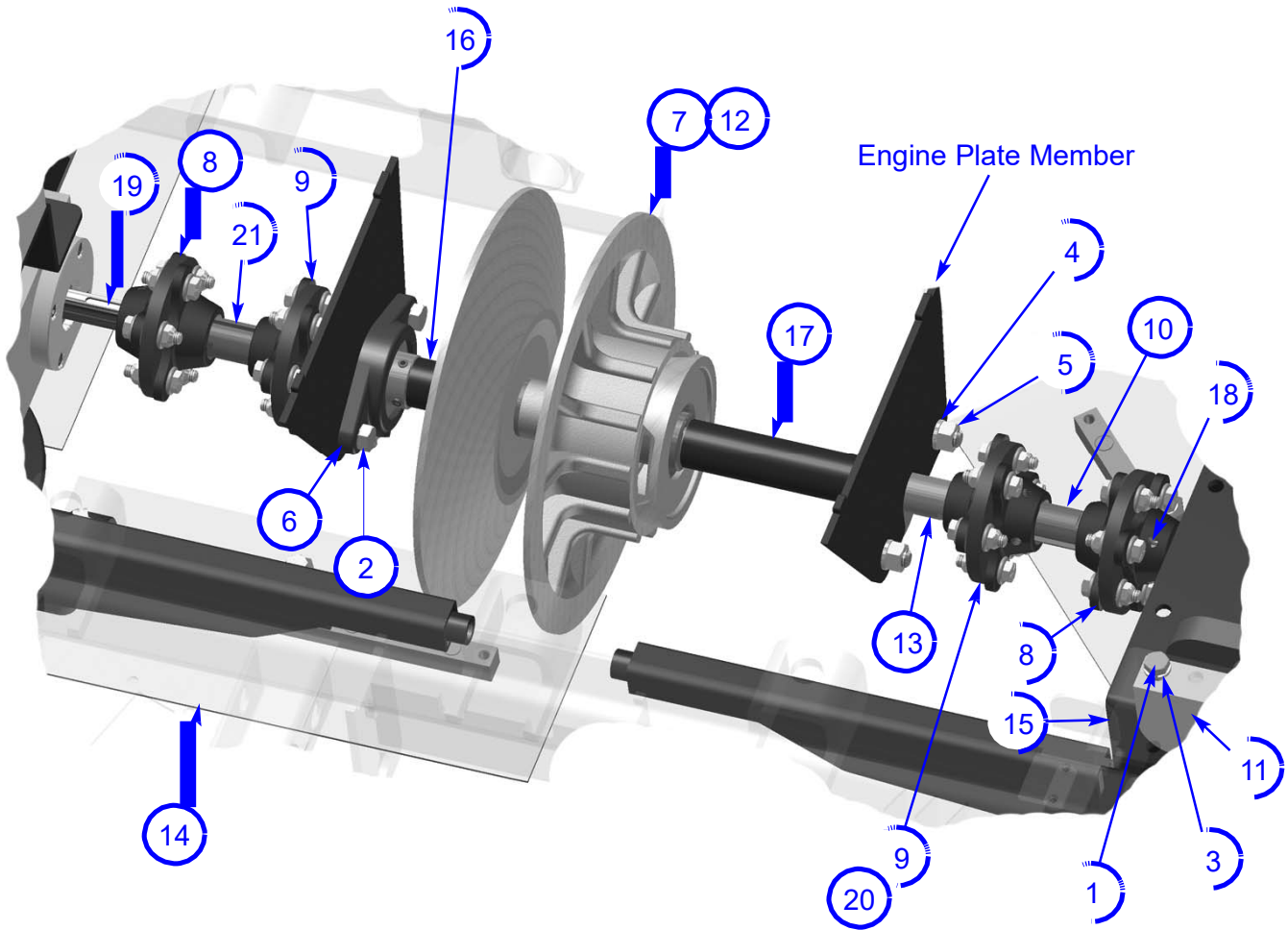

4.7 Parts List Driveline System

SECTION 4 PARTS

ITEM	PART #	DESCRIPTION	QTY
1	010035	FSTN, HHCS 3/8-16 X 3/4	8
2	010053	FSTN, HHCS 7/16-14 X 1-1/4	4
3	010091	FSTN, LW 3/8	8
4	010092	FSTN, LW 7/16	4
5	010104	FSTN, HEX NUT 7/16-14	4
6	019334	BEARING, Ø1 ID SCJT-1 FLANGE	2
7	024820	STOCK, 1/4 SQx4 LG KEY	1
8	024967	COUPLER, Ø3/4xØ1 FLEX DISC	2
9	024968	COUPLER, Ø1xØ1 FLEX DISC	2
10	024971	SHAFT, DRIVE END 3-1/8"	2
11	048561	BEARING ASSEMBLY F/ ROTOR MOUNT	4
12	048919	PULLEY, DRIVEN	1
13	050070	SHAFT, DRIVE 17 1/2 F/LOCK BEARING	1
14	053102	ROTOR ASSEMBLY, RH	1
15	053103	ROTOR ASSEMBLY, LH	1
16	053193	SPACER, BEARING, 1 3/8"	1
17	053194	SPACER, BEARING, 4 3/4"	1
18	010313	FSTN, SHSSKP/NP 5/16-18 X 3/8	16
19	010273	KEY, 3/16" SQ X 2" LG	2
20	011791	KEY, 1/4" SQ X 1" LG	2
21	026992	KEY, 1/4" SQ X 3-1/8" LG	2

SECTION 4 PARTS

4.8 Electrical Schematic

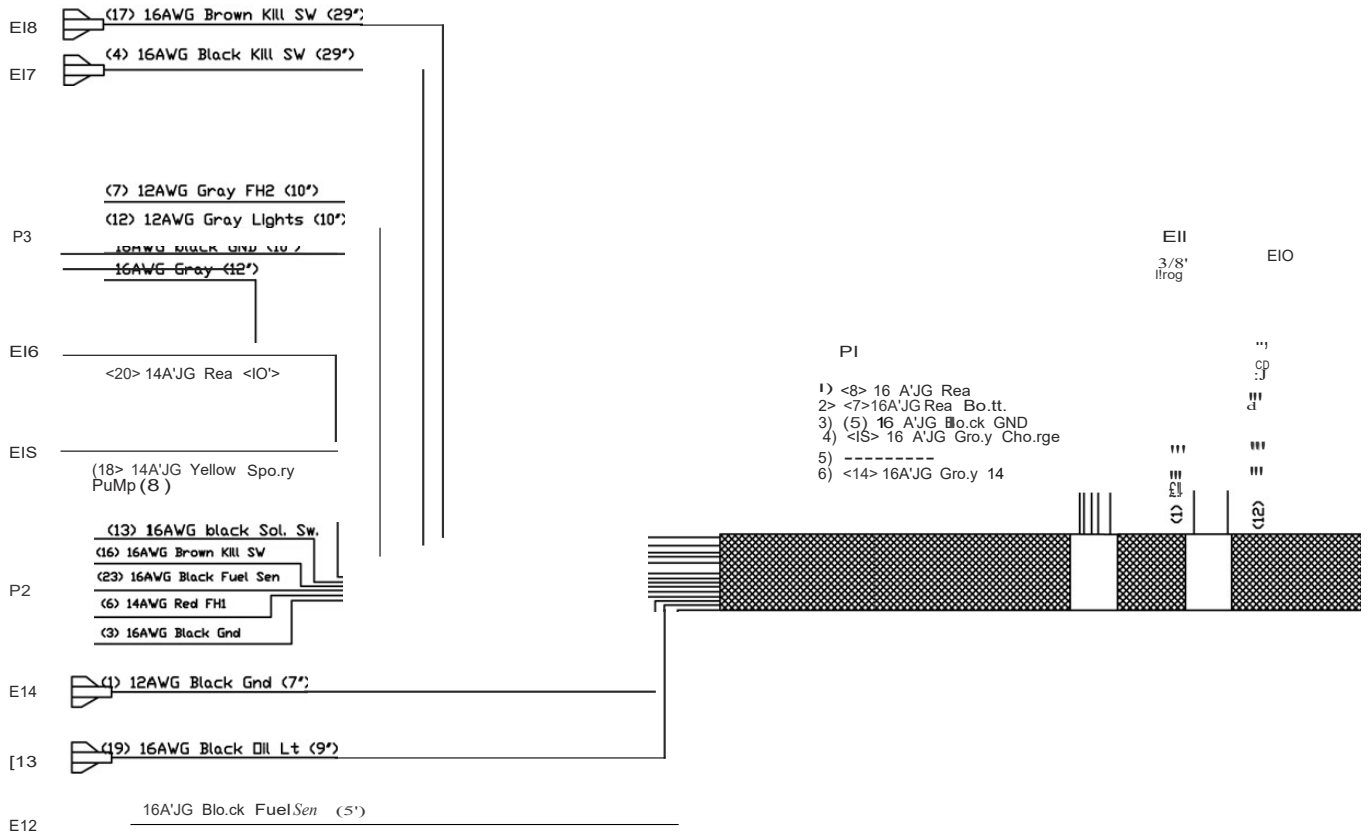

4.8 Electrical Schematic (cont'd)

SECTION 4 PARTS

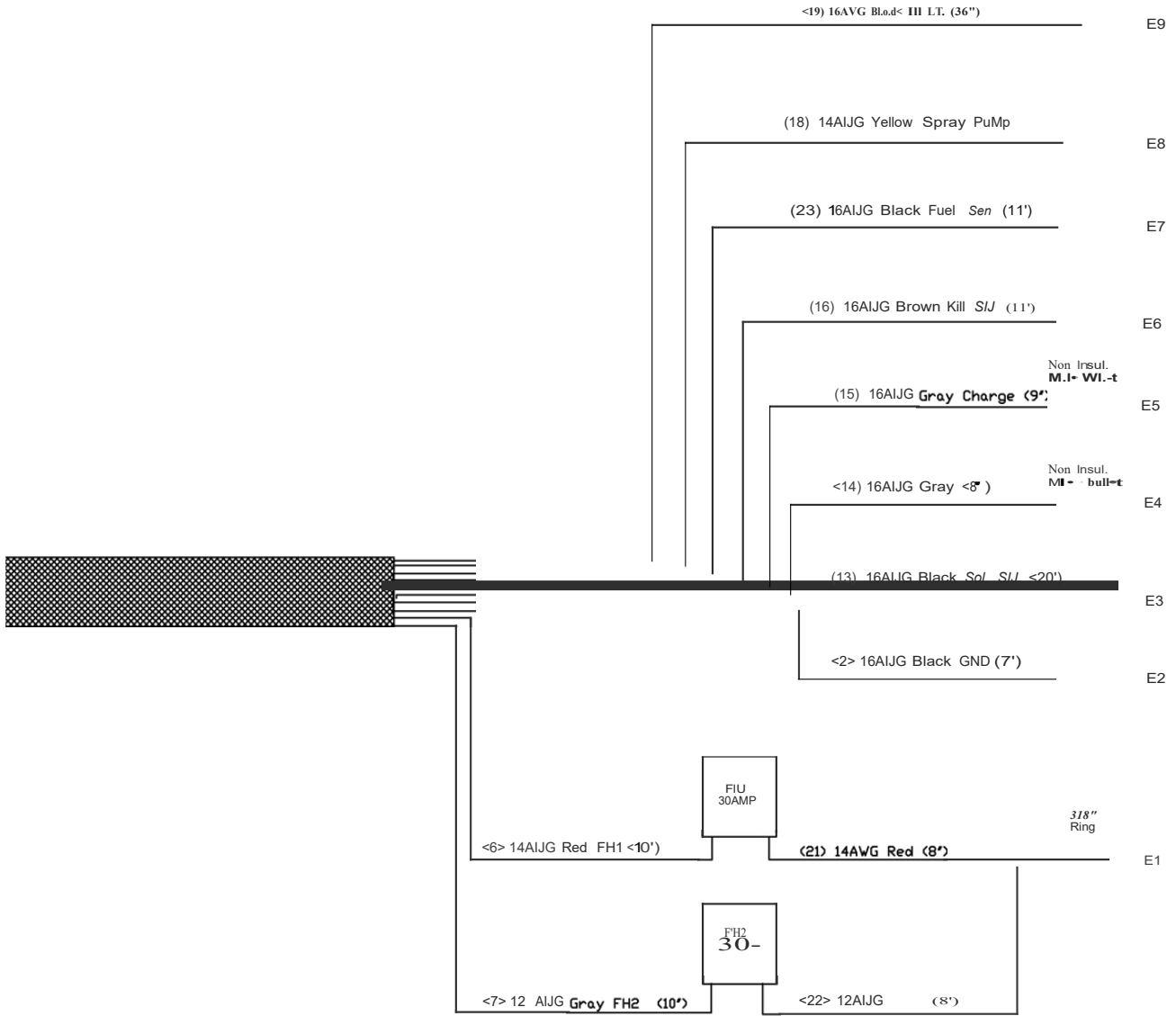

SECTION 4
PARTS

4.9 Illustration
Right Hand Rotor Assembly

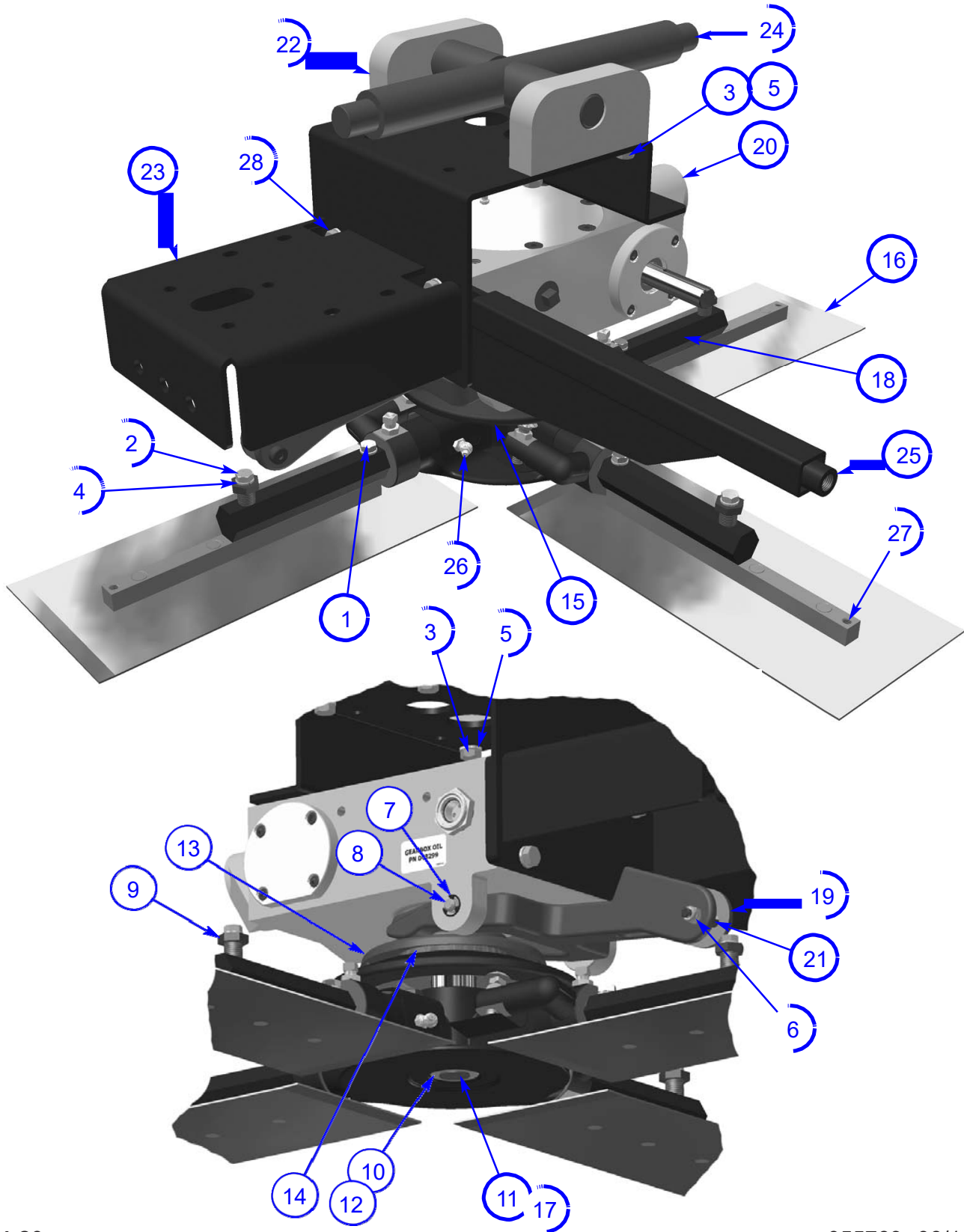

4.9 Parts List Right Hand Rotor Assembly

SECTION 4 PARTS

ITEM	PART #	DESCRIPTION	QTY
1	010023	FSTN, HHCS 5/16-18 X 3/4 GR 5	4
2	010024	FSTN, HHCS 5/16-18 X 2 GR 5	4
3	010035	FSTN, HHCS 3/8-16 X 3/4	8
4	010090	FSTN, LW 5/16	8
5	010091	FSTN, LW 3/8	10
6	012612	FSTN, NUT HEX NYLOCK 5/16-18	1
7	015677	RING, Ø7/16 E-STYLE RETAINING	2
8	015678	PIN, YOKE ARM	1
9	015688	FSTN, 9/16-18 NF ADJ/MACH SCRW	4
10	015690	WASHER, RETAINING FOR TROWELS	1
11	015693	PLUG, PLASTIC CAP EC12	1
12	015696	KEY, .25x1.25 LG HARD RAD	1
13	015821	CAP, PRESSURE PLATE	1
14	015822	THRUST BEARING	1
15	015824	PLATE, PRO RIDER/WALKER PRESSURE	1
16	015890	TROWEL BLADE, FINISH 6 X 14	4
17	020155	SCR, 1/2-13 X 1-1/2 LH SHCS	1
18	024813	SPIDER ASSY, RH-SOM	1
19	026215	YOKE, ARM	1
20	026443	GEARBOX, STD RH (SOM)	1
21	026504	SCR, 5/16-18x1/2xØ3/8x1-1/4 SHLDR	1
22	048561	BEARING ASSEMBLY F/ ROTOR MOUNT	2
	048559	BAR, BEARING HOUSING ALUM	
	048560	BEARING, I-GLIDE FLANGED	
23	050017	HSNG, GEARBOX	1
24	050020	CROSSHEAD, 4-WAY	1
25	053109	STEERING ARM WMNT	1
26	015692	CAP, Ø1/4 RED GREASE	4
27	015694	PLUG W-1 RED PLASTIC TAPERED	4
28	015884	FSTN, SHCS 3/8-16 X 1	2

SECTION 4
PARTS

4.10 Illustration
Left Hand Rotor Assembly

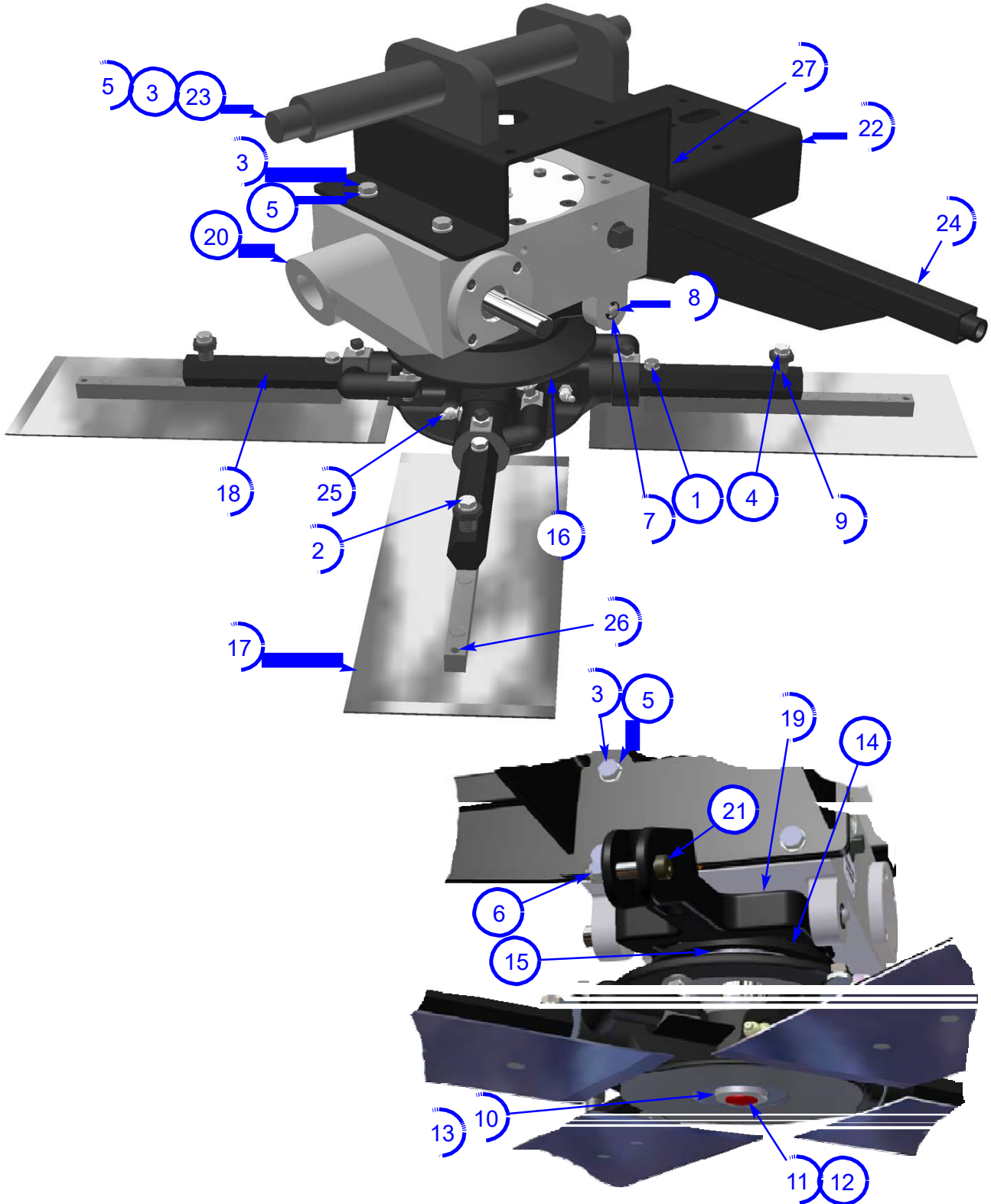

4.10 Parts List Left Hand Rotor Assembly

SECTION 4 PARTS

ITEM	PART #	DESCRIPTION	QTY
1	010023	FSTN, HHCS 5/16-18 X 3/4 GR 5	4
2	010024	FSTN, HHCS 5/16-18 X 2 GR 5	4
3	010035	FSTN, HHCS 3/8-16 X 3/4	10
4	010090	FSTN, LW 5/16	8
5	010091	FSTN, LW 3/8	10
6	012612	FSTN, NUT HEX NYLOCK 5/16-18	1
7	015677	RING, Ø7/16 E-STYLE RETAINING	2
8	015678	PIN, YOKE ARM	1
9	015688	FSTN, 9/16-18 NF ADJ/MACH SCRW	4
10	015690	WASHER, RETAINING FOR TROWELS	1
11	015691	FSTN, SHCS 1/2-13 X 1-1/2 RH	1
12	015693	PLUG, PLASTIC CAP EC12	1
13	015696	KEY, .25x1.25 LG HARD RAD	1
14	015821	CAP, PRESSURE PLATE	1
15	015822	THRUST BEARING	1
16	015824	PLATE, PRO RIDER/WALKER PRESSURE	1
17	015890	TROWEL BLADE, FINISH 6 X 14	4
18	015893	SPIDER ASSY, LH-SOM	1
19	026215	YOKE, ARM	1
20	026442	GEARBOX, STD LH (SOM)	1
21	026504	SCR, 5/16-18x1/2xØ3/8x1-1/4 SHLDR	1
22	050017	HSNG, GEARBOX	1
23	050022	CROSSHEAD, 2-WAY	1
24	053109	STEERING ARM WMNT	1
25	015692	CAP, Ø1/4 RED GREASE	4
26	015694	PLUG W-1 RED PLASTIC TAPERED	4
27	015884	FSTN, SHCS 3/8-16 X 1	2

SECTION 4
PARTS

4.11 Illustration
Right Hand Spider Assembly

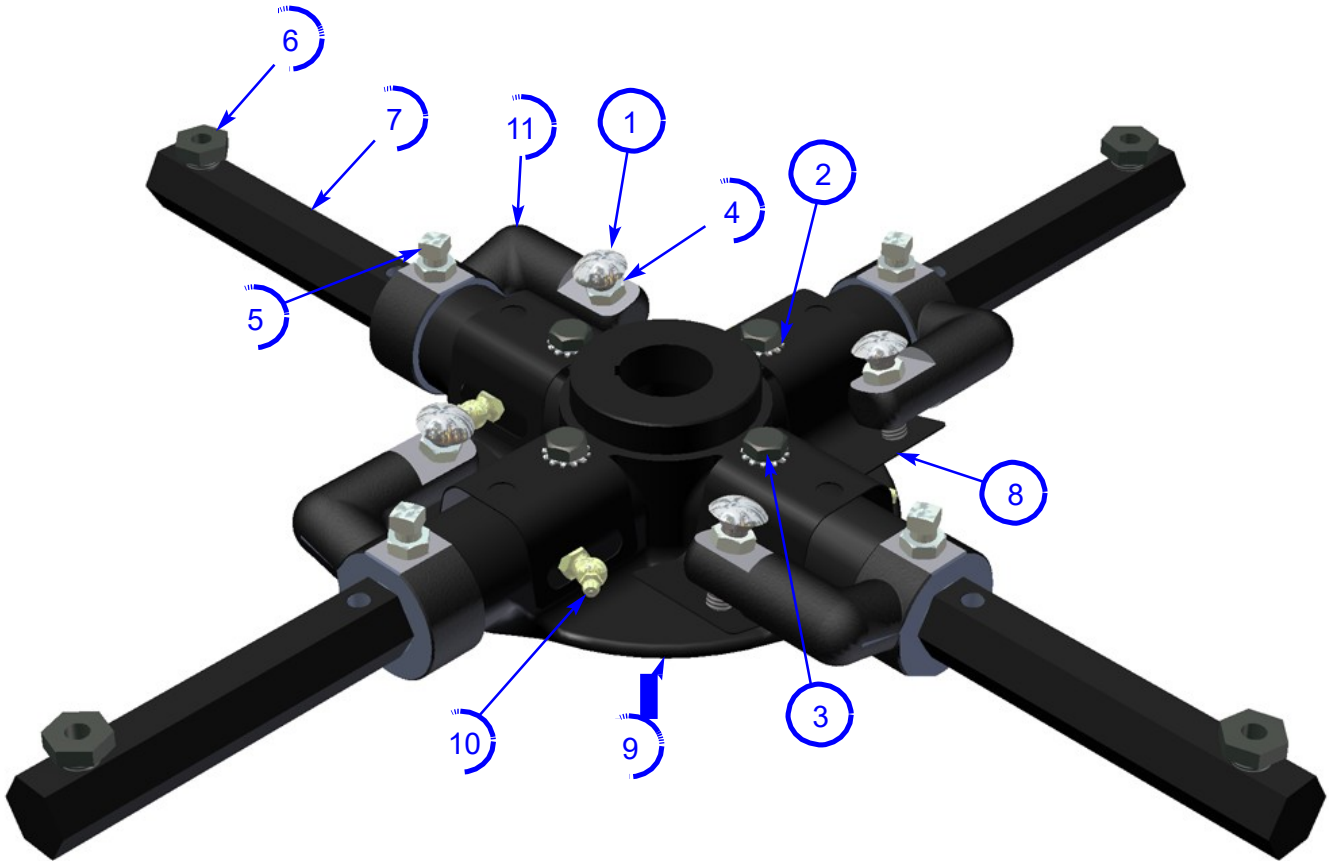

4.11 Parts List Right Hand Spider Assembly

SECTION 4 PARTS

ITEM	PART #	DESCRIPTION	QTY
	024813	SPIDER ASSY, RH-SOM	
1	012990	FSTN, CABLT 3/8-16 X 1-1/4"	4
2	015682	FSTN, LW EXT STAR 3/8	4
3	015683	BOLT, 3/8-16 X 7/8 DOG PT HEX HD CAP	4
4	015684	FSTN, NUT HEX JAM 3/8-16	8
5	015686	FSTN, SQHSS 3/8-16 X 1	4
6	015688	FSTN, 9/16-18 NF ADJ/MACH SCRW	4
7	015818	TROWEL ARM, STD 36" SPIDER	4
8	016920	SPRING CLIP, UNIVERSAL SPIDERS	4
9	020572	SPIDER, 4-BOSS MACH CCW SD	1
10	024755	FITTING, 1/8-27 NPT 45° GREASE	4
11	033032	LIFT LEVER, STD UNIVERSAL	4

SECTION 4
PARTS

4.12 Illustration
Left Hand Spider Assembly

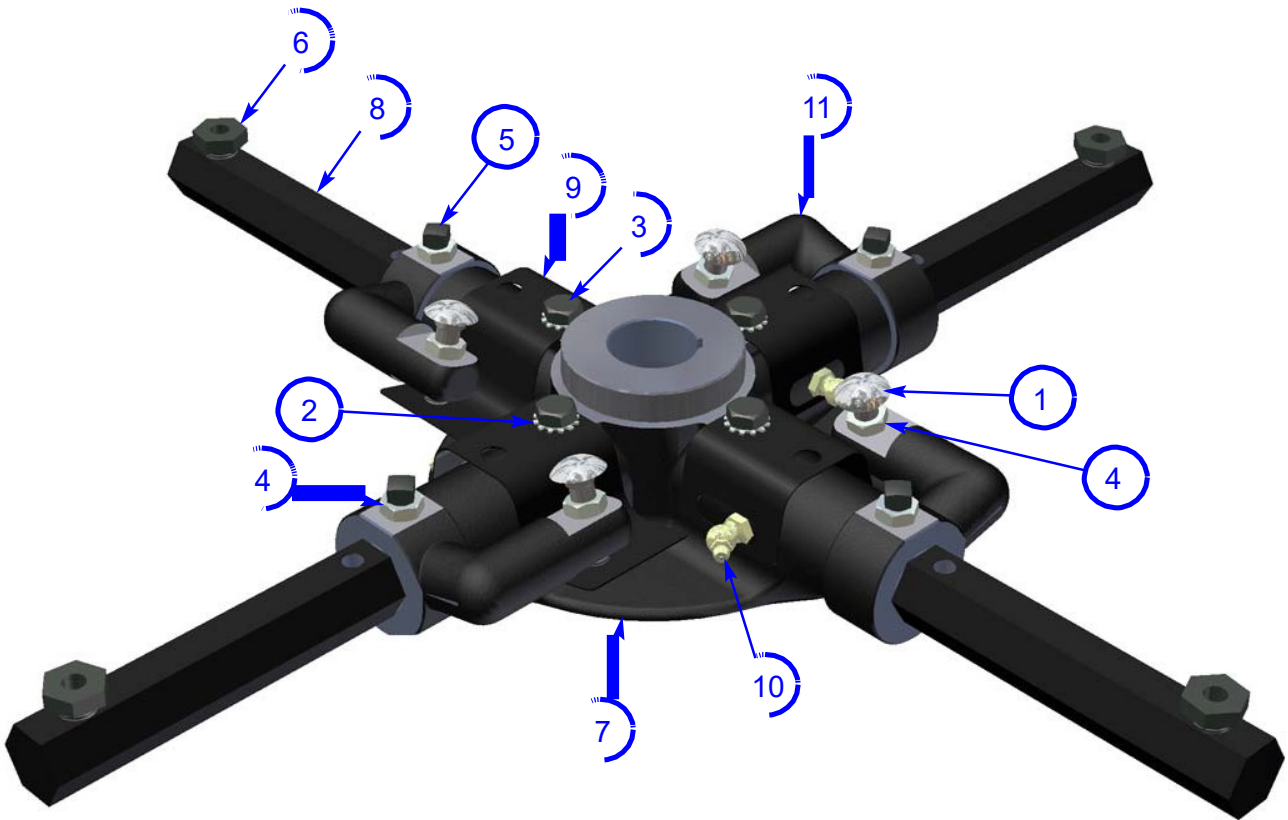

4.12 Parts List Left Hand Spider Assembly

SECTION 4 PARTS

ITEM	PART #	DESCRIPTION	QTY
	015893	SPIDER ASSY, LH-SOM	-
1	012990	FSTN, CABLT 3/8-16 X 1-1/4"	4
2	015682	FSTN, LW EXT STAR 3/8	4
3	015683	FSTN, 3/8-16 X 7/8 DOG CAP SCREW	4
4	015684	FSTN, NUT HEX JAM 3/8-16	8
5	015686	FSTN, SQHSS 3/8-16 X 1	4
6	015688	FSTN, 9/16-18 NF ADJ/MACH SCRW	4
7	015816	SPIDER, 4-BOSS MACH CW STD	1
8	015818	TROWEL ARM, STD 36" SPIDER	4
9	016920	SPRING CLIP, UNIVERSAL SPIDERS	4
10	024755	FITTING, 1/8-27 NPT 45° GREASE	4
11	033032	LIFT LEVER, STD UNIVERSAL	4

SECTION 4 PARTS

4.13 Illustration RH Standard Duty Gearbox

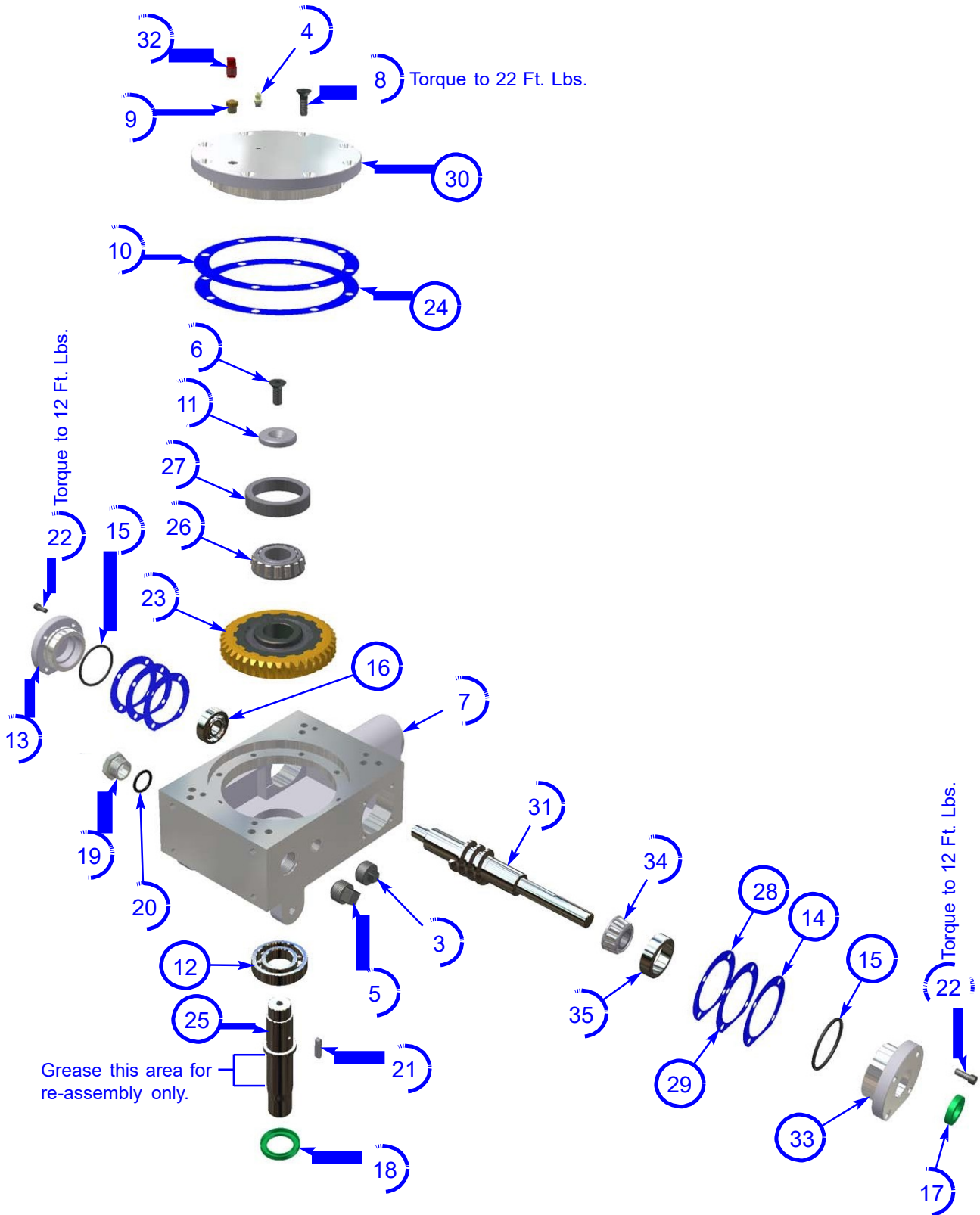

4.13 Parts List RH Standard Duty Gearbox

SECTION 4 PARTS

ITEM	PART #	DESCRIPTION	QTY
1	001003	GREASE, MOBILITH SCH 220	.094
2	048299	OIL, GEARBOX	.757/LT
3	010498	PLUG, 3/8 NPT BI SQ HD PIPE	1
4	010513	FITTING, 1/4-28 NPT STR GREASE	1
5	012953	PLUG, 3/4 NPTF BI SQ HD PIPE	1
6	013746	FSTN, FHCSS 3/8-16 X 1	1
7	015204	GEAR BOX,MACHINE FINISHED	1
8	015205	FSTN, SCREW FHSSS 5/16-18 X 1	8
9	015209	VALVE 1/8 NPT-27 RELIEF	1
10	015210	GASKET .005 THICK, TOP COVER	AS REQ.
11	015213	WASHER PRESSURE	1
12	015217	BEARING, RADIAL BALL	1
13	015221	CAP,GEAR BOX END	1
14	015222	GASKET, END CAP & FLANGE .005	AS REQ.
15	015660	O-RING, GEAR BOX END CAPS	2
16	015663	BEARING ANGULAR CONTACT	1
17	015670	SEAL, OIL CR# 7455V	1
18	015671	SEAL, OIL CR# 13661	1
19	015672	GAUGE, 3/4-14 NPT PORTHOLE VIEW	1
20	015673	O-RING, 15/16x1-3/16x1/8 BUNA	1
21	015696	KEY, .25x1.25 LG HARD RAD	1
22	017314	FSTN, SHCS 1/4-20 X 5/8	8
23	018924	GEAR,BRONZE LH	1
24	020018	GASKET .003 THICK, TOP COVER	AS REQ.
25	020120	SHAFT, MAIN MACH FINISHED	1
26	022073	BEARING TAPERED ROLLER	1
27	022074	BEARING RACE	1
28	022185	GASKET, END CAP & FLANGE .002	AS REQ.
29	022186	GASKET, END CAP & FLANGE .003	AS REQ.
30	026406	COVER-GEAR BOX MACH. FINISHED	1
31	026741	SHAFT, INPUT LH GEAR BOX	1
32	032745	PLUG, PLASTIC 1/8" P18-27 (TRANSPORT ONLY)	1
33	044601	FLANGE, GEAR BOX (4 HOLE)	1
34	044603	BEARING, TAPERED ROLLER	1
35	044604	BEARING RACE	1

SECTION 4 PARTS

4.14 Illustration LH Standard Duty Gearbox

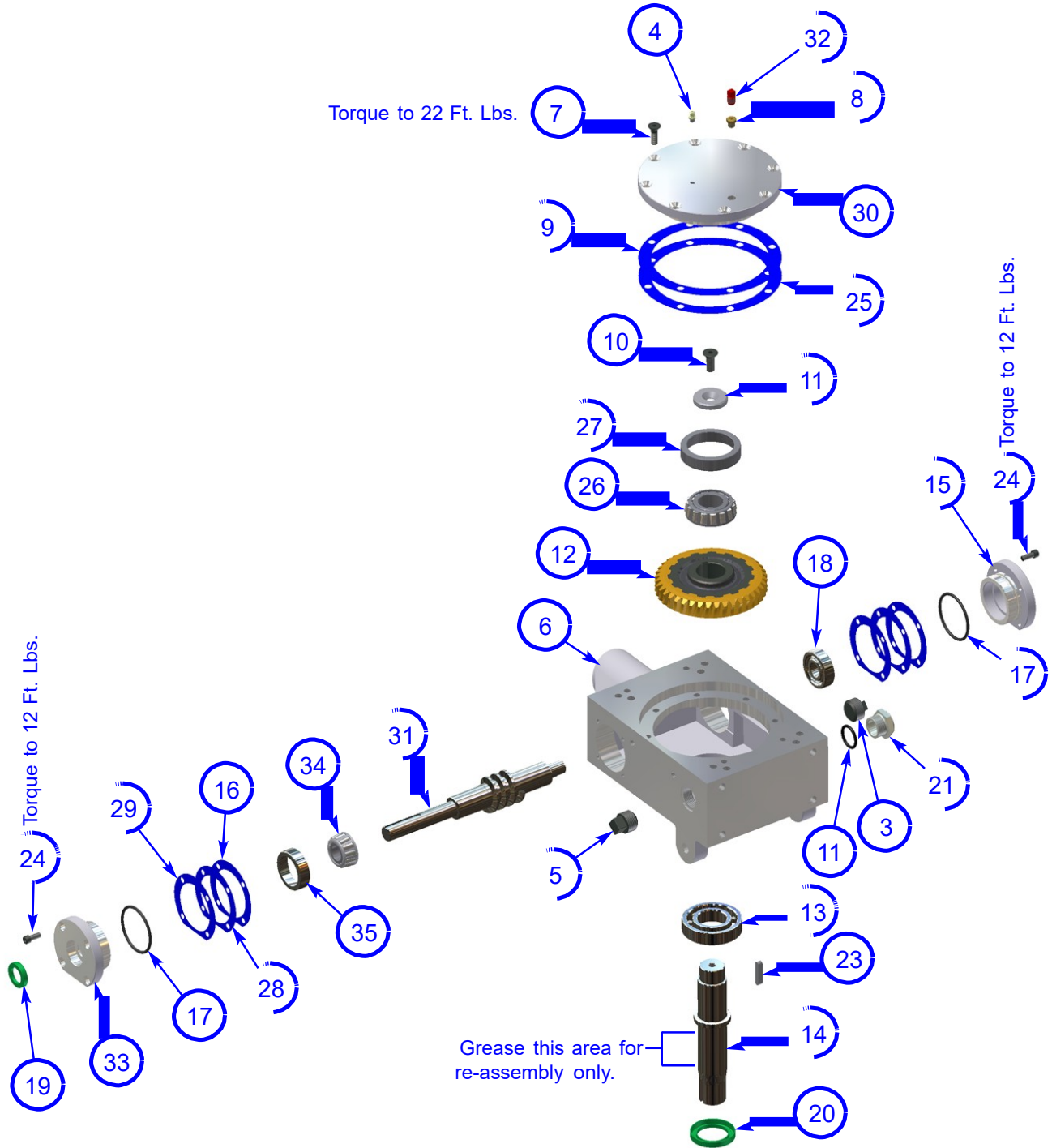

4.14 Parts List LH Standard Duty Gearbox

SECTION 4 PARTS

ITEM	PART #	DESCRIPTION	QTY
1	001003	GREASE, MOBILITH SCH220	.094
2	048299	OIL, GEARBOX	.757/LT
3	010498	PLUG, 3/8 NPT BI SQ HD PIPE	1
4	010513	FITTING, 1/4-28 NPT STR GREASE	1
5	012953	PLUG, 3/4 NPTF BI SQ HD PIPE	1
6	015204	GEAR BOX,MACHINE FINISHED	1
7	015205	FSTN, SCREW FHSSS 5/16-18 X 1	8
8	015209	VALVE 1/8 NPT-27 RELIEF	1
9	015210	GASKET .005 THICK, TOP COVER	AS REQ.
10	015212	FSTN, SCREW FHSS 3/8-16 X 1 LH	1
11	015213	WASHER PRESSURE	1
12	015216	GEAR,BRONZE RH	1
13	015217	BEARING, RADIAL BALL	1
14	015219	SHAFT, MAIN MACH FINISHED	1
15	015221	CAP, GEAR BOX END	1
16	015222	GASKET, END CAP & FLANGE .005	AS REQ.
17	015660	O-RING, GEAR BOX END CAPS	2
18	015663	BEARING ANGULAR CONTACT	1
19	015670	SEAL, OIL CR# 7455V	1
20	015671	SEAL, OIL CR# 13661	1
21	015672	GAUGE, 3/4-14 NPT PORTHOLE VIEW	1
22	015673	O-RING, 15/16x1-3/16x1/8 BUNA	1
23	015696	KEY, .25x1.25 LG HARD RAD	1
24	017314	FSTN, SHCS 1/4-20 X 5/8	8
25	020018	GASKET .003 THICK, TOP COVER	AS REQ.
26	022073	BEARING TAPERED ROLLER	1
27	022074	BEARING RACE	1
28	022185	GASKET, END CAP & FLANGE .002	AS REQ.
29	022186	GASKET, END CAP & FLANGE .003	AS REQ.
30	026406	COVER-GEAR BOX MACH. FINISHED	1
31	026740	SHAFT, INPUT RH GEAR BOX	1
32	032745	PLUG, PLASTIC 1/8" P18-27 (TRANSPORT ONLY)	1
33	044601	FLANGE, GEAR BOX (4 HOLE)	1
34	044603	BEARING, TAPERED ROLLER	1
35	044604	BEARING RACE	1

SECTION 4
PARTS

4.15 Illustration
Accessory - Dolly Jack System

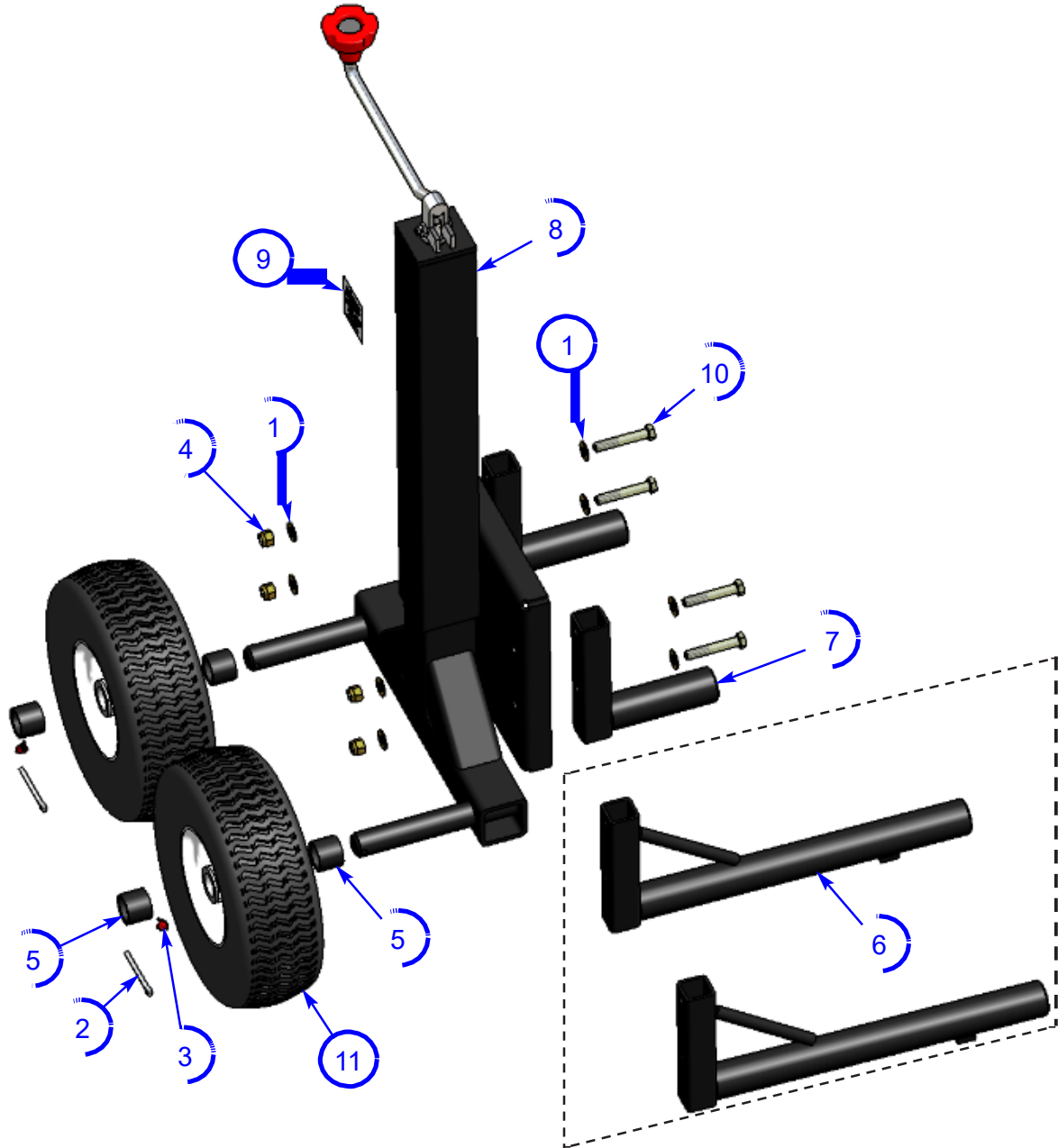

4.15 Parts List Accessory - Dolly Jack System

SECTION 4 PARTS

ITEM	PART #	DESCRIPTION	QTY
-	027684	SET, PRO DOLLY JACK	1
1	017751	WASHER, 3/8 FLAT	16
2	010133	PIN, 3/16 X 2 COTTER	4
3	015692	CAP, 1/4 RED GREASE	4
4	010464	NUT, 3/8-16 NYLOCK LOCK	8
5	024628	SPACER, DOLLY JACK WHEEL	8
6	026728	ASSEMBLY, REAR DOLLY TUBE	2
7	026729	ASSEMBLY, DOLLY JACK TUBE	2
8	026938	JACK, DOLLY	2
9	039633	DECAL, DOLLY JACK SYSTEM	2
10	040637	SCREW, 3/8-16 X 2-1/4 GRADE 8 HEX HD CAP	8
11	099014	ASSEMBLY, PNEUMATIC TIRE AND WHEEL	4

SECTION 4
PARTS

4.18 Illustration
Accessory - Non-standard Items

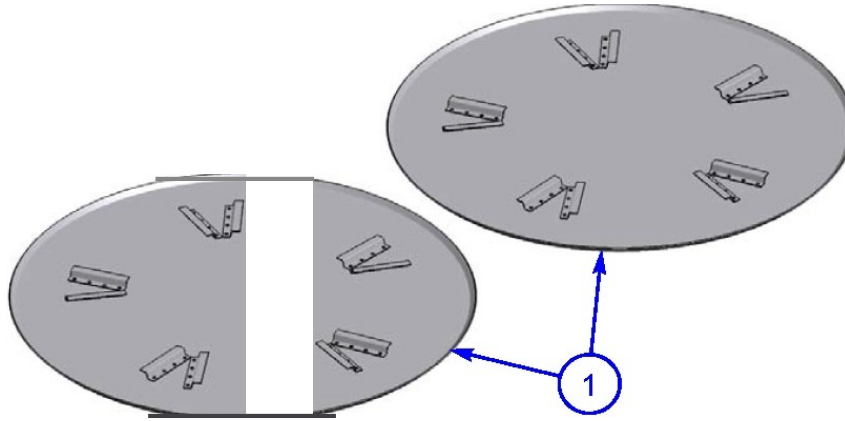

4.16 Parts List Accessory - Non-standard Items

SECTION 4 PARTS

ITEM	PART #	DESCRIPTION	QTY
1	047128	PAN, UNIVERSAL 36-1/2" 4-CLIP	2
	047130	PAN, UNIVERSAL 11GA 36-1/2" 4-SAFETY	2
	046297	COMPODISK, 37-5/16" OD X 3/4" (4)	2
2	035461	BRIDLE, 2500 LB 5 FT SLING LIFT	1

SECTION
PARTS

4.17 Illustration
Tools·Service

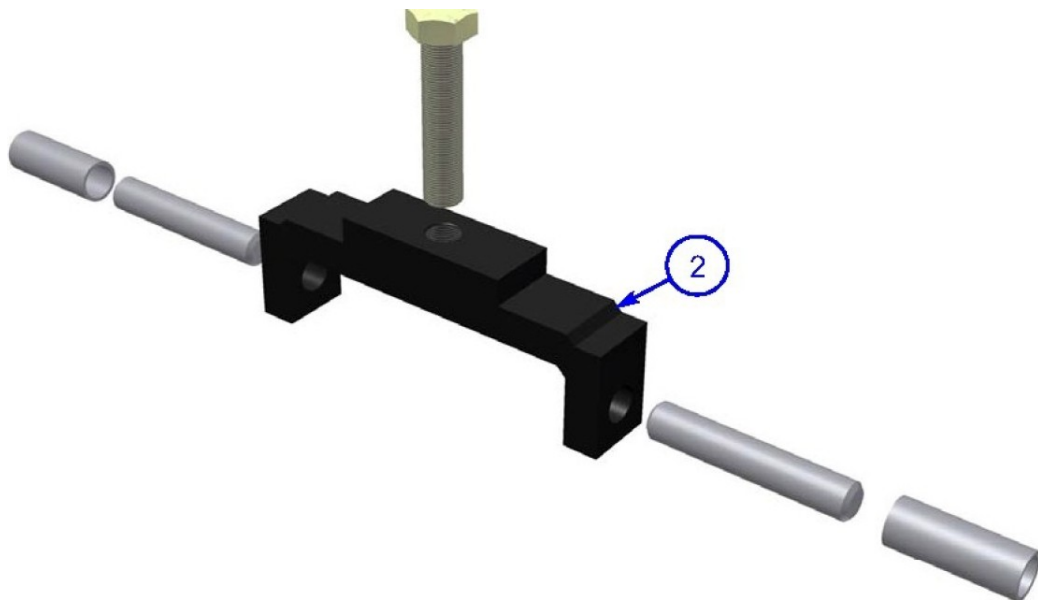
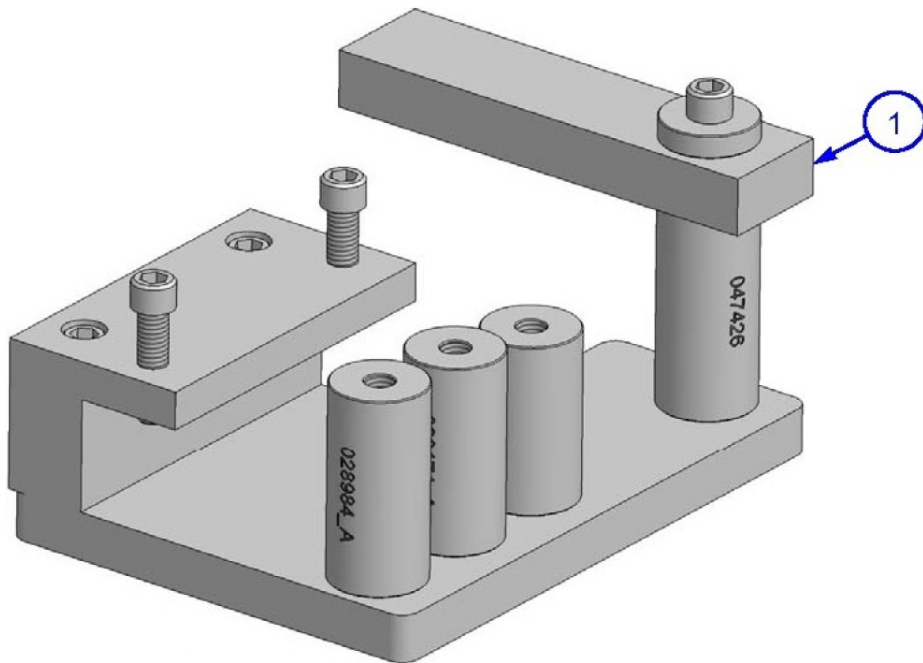

4.17 Parts List Tools - Service

SECTION 4 PARTS

ITEM	PART #	DESCRIPTION	QTY
1	016863	JIG, TROWEL ARM ALIGNMENT	1
2	035688	KIT, STD 4-ARM SPIDER PULLER	1

SECTION 4

PARTS

Notes



Uni-corp Europe
PACLITE Equipment
12 avenue des Coquelicots
94380 Bonneuil-sur-Marne
FRANCE

www.paclite-equip.com