

Reversible plate compactors

A series of reversible plates with an operating width of 500 and 600 mm, offer robustness and compact size, and are easy to operate on any construction site.

IMPACT series are equipped with low vibration-isolating handles, ergonomically designed and comfortable.

This equipment combines high efficiency, speed and depth of compaction. The hydraulic servo control acts on the vibrating element, providing smooth uniform movement and easy driving. The low vibration handle constitutes one of the most important advantages of this plate.

It is fixed on specially designed shock absorbing blocks with its exceptional compaction parameters (strength centrifuge: 30 kN), it provides excellent results for the compaction of granular materials in trenches, foundation and road repair projects.

FEATURES AND BENEFITS

- Lifelong lubricated bearings for extended service life.
- Exciter bearing design requires minimal maintenance for improved productivity.
- Strong V-belt cover.
- 30 kN excentric element.
- Convenient single lifting point.
- Standard engine: Honda 4-stroke or Hatz Diesel.
- Engine with oil alert on all models.
- Option: electric start.
- Low hand-arm vibration handle.



Powered by
HATZ
DIESEL

POWERED BY
HONDA
norm SAE J1349

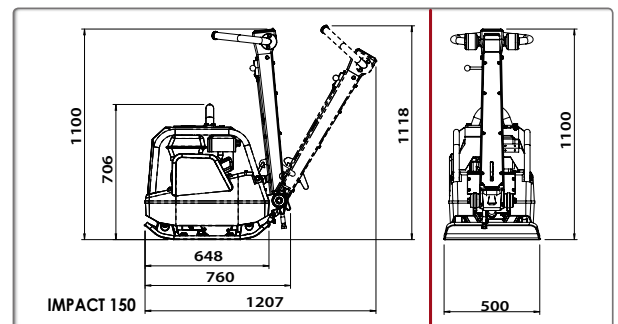
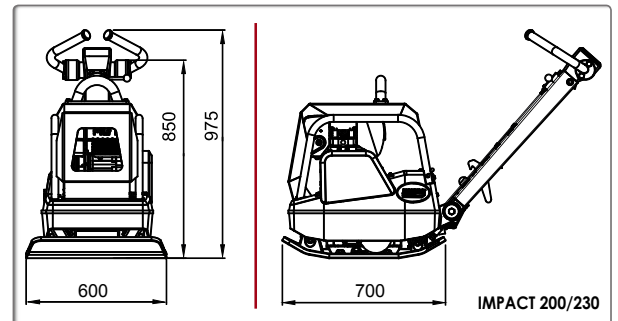

Moulded bottom plate

IMPACT 230 with electric starter



Handle with integrated electric starter box



Model	IMPACT 150	IMPACT 200	IMPACT 230	
Code	IMP150H	IMP200H	IMP200D	IMP230DEHS
Engine	Honda GX160	Honda GX270	Hatz 1B20	Hatz 1B20
Net power hp (kW)	4,8 (3,6)	8,5 (6,3)	4,6 (3,5)	4,6 (3,5)
Max. Engine speed (rpm/min)	3600	3600	3300	3300
Plate dimensions L x W (mm)	648 x 500	700 x 600	700 x 600	700 x 600
Operating weight (kg)	150	217	230	238
Centrifugal force (kN)	35	30	30	30
Operating speed (m/min)	22	21	21	21
Compacted area (m ² /h)	605	700	630	630
Frequency (Hz)	90	90	90	90
Start	Manual	Manual	Manual	Electric
Vibrations* m/sec ² /utilisation (hrs)	2,9/4,33	3,5/4,33	3,5/4,33	2,8/4,33
Sound pressure level dB (A)	105	105	105	105

* Minimum vibration levels measured to EN500-4

Certified power SAE J 1349