

# TR-670R-01 FUEL TANK & HANDLE ASSY

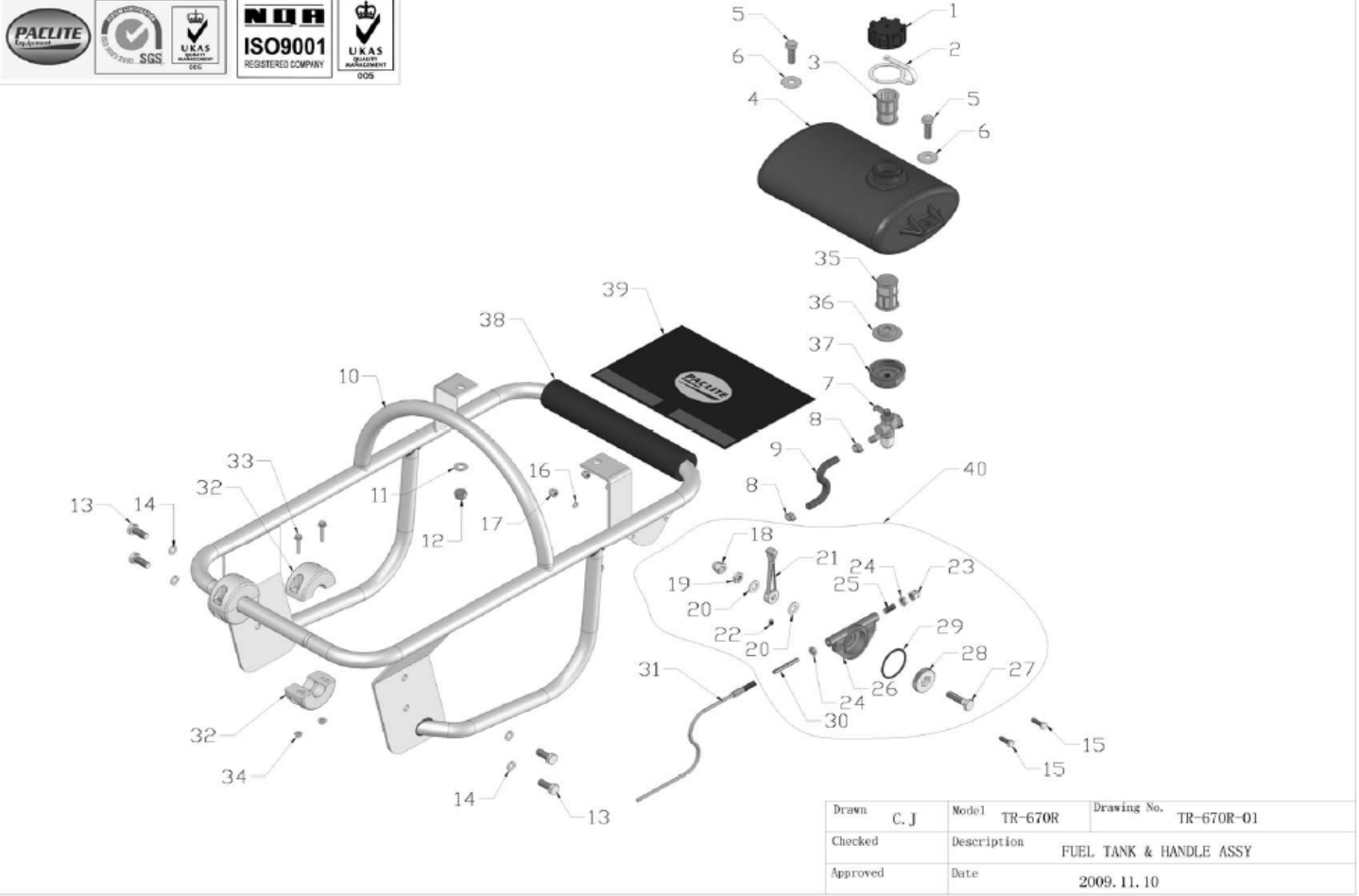

Drawn	C. J	Model	TR-670R	Drawing No.	TR-670R-01
Checked		Description	FUEL TANK & HANDLE ASSY		
Approved		Date	2009. 11. 10		

## TR-670R-01 FUEL TANK & HANDLE ASSY

NO. 序号	PART NO. 图号	PART DESCRIPTION 品名	QTY 数量	UNIT PRICE (EUR)
01-1	TR-670R-70B-010112P	FUEL TANK CAP (油箱盖)	1	
01-2	TR-670R-70B-010113P	STRAP (连接带)	1	
01-3	TR-670R-70B-010110	STRAINER (滤网)	1	
01-4	TR-670R-85d-010109	FUEL TANK (油箱)	1	
01-5	TR-670R-FN.B-M10x30-8.8-DIN-1	BOLT (六角螺栓)	2	
01-6	TR-670R-WOD.W10-GB-1	WASHER (大垫圈)	2	
01-7	TR-670R-70B-000020	FUEL VALVE (燃油开关)	1	
01-8	TR-670R-70B-000021	HOSE BAND (油管卡簧)	2	
01-9	TR-670R-70B-000022	FUEL HOSE (进油管)	1	
01-10	TR-670R-85d-010100P	OPERATION HANDLE (扶手)	1	
01-11	TR-670R-FN.W10-DIN-1	WASHER (平垫)	2	
01-12	TR-670R-IN.N-M10-DIN-1	LOCK NUT (防松螺母)	2	
01-13	TR-670R-FN.B-M10x25-8.8-DIN-1	BOLT (六角螺栓)	4	
01-14	TR-670R-SPG.W10-DIN-1	SPRING WASHER (弹垫)	4	
01-15	TR-670R-FN.B-M6x20-8.8-DIN-2	BOLT (六角螺栓)	2	
01-16	TR-670R-SPG.W6-DIN-2	SPRING WASHER (弹垫)	2	
01-17	TR-670R-HC.N-M6-DIN-2	CAP NUT (盖型螺母)	2	
01-18	TR-670R-HC.N-M10-DIN-2	CAP NUT (盖形螺母)	1	
01-19	TR-670R-FNL.N-M10-DIN-2	HEXAGON THIN NUT (六角薄螺母)	1	
01-20	TR-670R-FN.W10-DIN-2	WASHER (平垫)	2	
01-21	TR-670R-70ND-060000	THROTTLE LEVER (油门开关把手)	1	
01-22	TR-670R-FHSS.S-M6x8-GB-3	SOCKET SCREW WITH FLAT HEAD (内六角平端紧定螺钉)	1	
01-23	TR-670R-HC.N-M8-DIN-2	CAP NUT (盖型螺母)	1	
01-24	TR-670R-FNL.N-M8-DIN-2	HEXAGON THIN NUT (六角薄螺母)	2	
01-25	TR-670R-FHSS.S-M8x20-GB-3	SOCKET SCREW WITH FLAT HEAD (内六角平端紧定螺钉)	1	
01-26	TR-670R-70ND-060001	THROTTLE BODY (油门把手盖)	1	
01-27	TR-670R-70ND-060003	BOLT (油门螺栓)	1	
01-28	TR-670R-70ND-060002	THROTTLE GEAR (齿轮)	1	
01-29	TR-670R-W04-45x3	O-RING (O形圈)	1	
01-30	TR-670R-70ND-060004	SLIDER (齿条)	1	
01-31	TR-670R-W06-S04-L650x850	THROTTLE CABLE (油门线)	1	
01-32	TR-670R-65ND-010100	ROLLER (滚轮)	4	
01-33	TR-670R-HF.B-M5x30-8.8-DIN-3	HEXAGON FLANGE BOLT (六角法兰面螺栓)	4	
01-34	TR-670R-HF.N-M5-DIN-3	HEXAGON FLANGE NUT (六角法兰面螺母)	4	
01-35	TR-670R-70ND-010114	STRAINER (滤网)	1	
01-36	TR-670R-70ND-010115	PACKING (滤网垫)	1	
01-37	TR-670R-85d-010113	FUEL TANK CAP ,BOTTOM (油箱底盖)	1	
01-38	TR-670R-70ND-000028	HANDLE FOAM (海绵护套)	1	
01-39	TR-670R-70ND-000029P	HANDLE FABRIC (扶手布)	1	
01-40	TR-670R-70ND-010018	THROTTLE LEVER ASSY (油门开关组件)	1	

# TR-670R-02 GEAR CASE & ENGINE ASSY

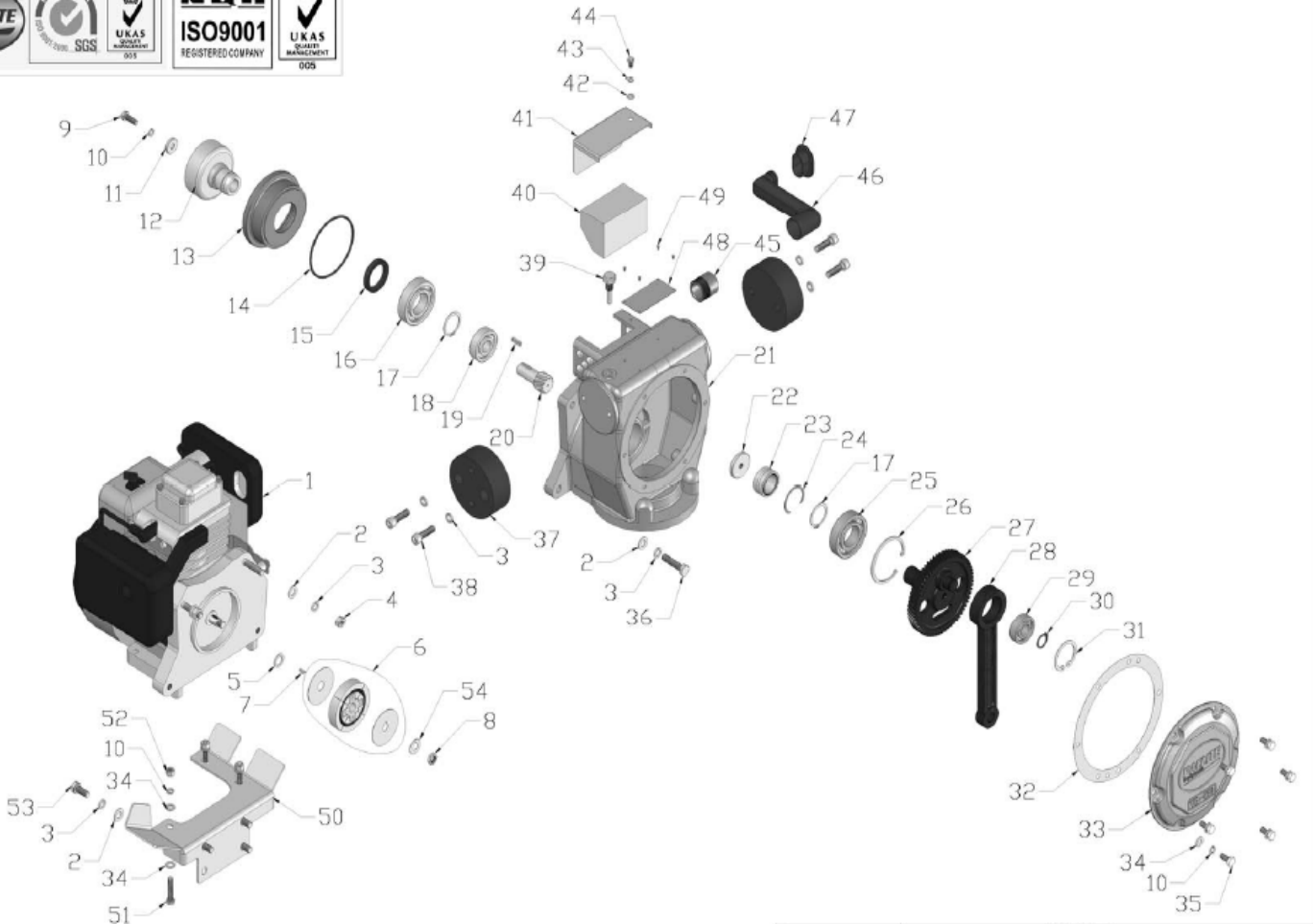

Drawn	C. J	Model	TR-670R	Drawing No.	TR-670R-02
Checked		Description	GEAR CASE & ENGINE ASSY		
Approved		Date	2009.11.10		

# TR-670R-02 GEAR CASE & ENGINE ASSY

NO. 序号	PART NO. 图号	PART DESCRIPTION 品名	QTY 数量	UNIT PRICE (EUR)
02-1	TR-670R-W05-EH12-2D	ENGINE (引擎)	1	
02-2	TR-670R-FN.W10-DIN-1	WASHER (平垫)	8	
02-3	TR-670R-SPG.W10-DIN-1	SPRING WASHER (弹垫)	12	
02-4	TR-670R-FN.N-M10-DIN-1	NUT (螺母)	2	
02-5	TR-670R-80-0997	WASHER (垫圈)	1	
02-6	TR-670R-W18-C812A	CENTRIFUGAL CLUTCH ASSY (离合器)	1	
02-7	TR-670R-WKey-4x4x13	WOODRUFF KEY (半圆键)	1	
02-8	TR-670R-FNL.N-M12x1.25-DIN-2	THIN NUT (细牙薄螺母)	1	
02-9	TR-670R-FN.B-M8x25-8.8-DIN-1	BOLT (六角螺栓)	1	
02-10	TR-670R-SPG.W8-DIN-1	SPRING WASHER (弹垫)	12	
02-11	TR-670R-70B-020129	LOCK WASHER (小齿轮固定垫圈)	1	
02-12	TR-670R-70B-020119	CLUTCH HOUSING (离合器盖)	1	
02-13	TR-670R-70B-020122	SPACER (衬套)	1	
02-14	TR-670R-W04-96x3.5	O RING (O型圈)	1	
02-15	TR-670R-W03-52x40x8	OIL SEAL (油封)	1	
02-16	TR-670R-W01-6207Z-J	BEARING (轴承)	1	
02-17	TR-670R-CS.RG35	EXTERNAL CIRCLIP (轴用挡圈)	2	
02-18	TR-670R-W01-6304-J	BEARING (轴承)	1	
02-19	TR-670R-Key.A-5x5x22	KEY (平键)	1	
02-20	TR-670R-70B-020124	PINION (小齿轮)	1	
02-21	TR-670R-70B-020116	CRANK CASE (齿轮箱)	1	
02-22	TR-670R-70B-020101	WASHER (起轴承片)	1	
02-23	TR-670R-W01-TAF324220 TR-670R-RT283220	BEARING (轴承)	1SET	
02-24	TR-670R-70B-020112	INTERNAL CIRCLIP (孔用档圈)	1	
02-25	TR-670R-W01-6207-J	BEARING (轴承)	1	
02-26	TR-670R-CH.RG72	INTERNAL CIRCLIP (孔用档圈)	1	
02-27	TR-670R-70B-020115	CRANK GEAR (大齿轮)	1	
02-28	TR-670R-70B-020102	CONNECTING ROD (连接杆)	1	
02-29	TR-670R-W01-6204-J	BEARING (轴承)	1	
02-30	TR-670R-CS.RG20	EXTERNAL CIRCLIP (轴用挡圈)	1	
02-31	TR-670R-CH.RG47	INTERNAL CIRCLIP (孔用挡圈)	1	
02-32	TR-670R-70B-020114	PACKING FRONT COVER (密封垫)	1	
02-33	TR-670R-65ND-020101P	FRONT COVER (前盖)	1	
02-34	TR-670R-FN.W8-DIN-1	WASHER (平垫)	14	
02-35	TR-670R-FN.B-M8x20-8.8-DIN-1	BOLT (六角螺栓)	8	
02-36	TR-670R-FN.B-M10x45-8.8-DIN-1	BOLT (六角螺栓)	2	
02-37	TR-670R-70B-020125	SHOCK ABSORBER (缓冲橡胶)	2	
02-38	TR-670R-HS.B-M10x35-8.8-GB-1	SCREW (内六角螺钉)	4	
02-39	TR-670R-70B-020106	BREATHER BOLT (通气塞)	1	
02-40	TR-670R-70B-020133	AIR CLEANER (空滤)	1	
02-41	TR-670R-70B-020145	COVER,AIR CLEANER (过滤罩盖)	1	
02-42	TR-670R-FN.W6-DIN-1	WASHER (平垫)	1	
02-43	TR-670R-SPG.W6-DIN-1	SPRING WASHER (弹垫)	1	
02-44	FN.B-M6x10-8.8-DIN-1	BOLT (六角螺栓)	1	

# TR-670R-02 GEAR CASE & ENGINE ASSY

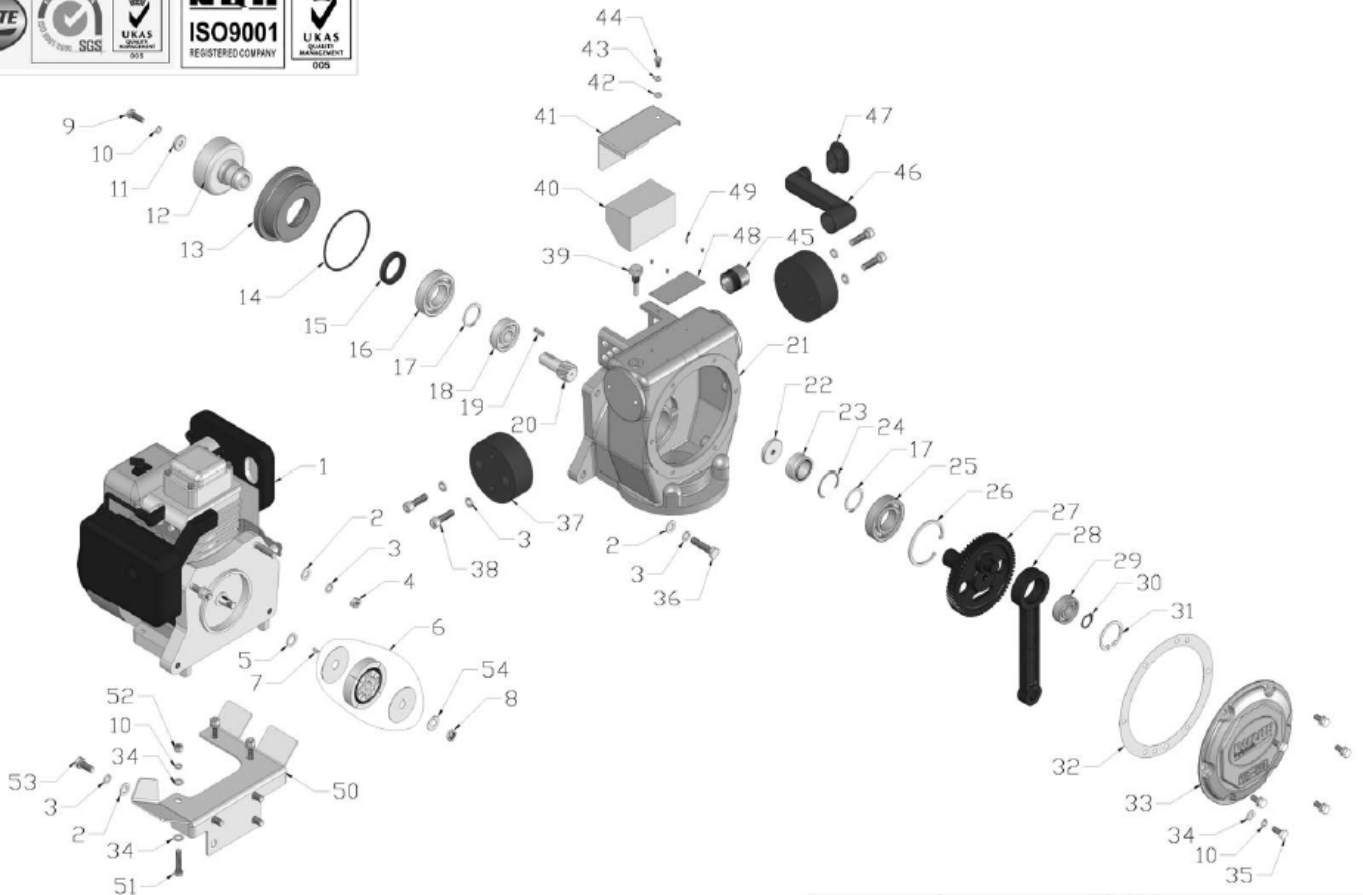

Drawn	C. J	Model	TR-670R	Drawing No.	TR-670R-02
Checked		Description	GEAR CASE & ENGINE ASSY		
Approved		Date	2009.11.10		

NO. 序号	PART NO. 图号	PART DESCRIPTION 品名	QTY 数量	UNIT PRICE (EUR)
02-45	TR-670R-70B-020131	CONNECTOR,GEAR CASE (管接头)	1	
02-46	TR-670R-70B-020148	INTAKE PIPE (通气管)	1	
02-47	TR-670R-70B-020146	CONNECTOR,ENGINE (橡胶套)	1	
02-48	TR-670R-80-0409	NAMEPLATE (铭牌)	1	
02-49	TR-670R-K.RVT-2.5x5	RIVET (铆钉)	4	
02-50	TR-670R-65ND-020300R	SUPPORT BASE, ENGINE (引擎托架)	1	
02-51	TR-670R-FN.B-M8x40-8.8-DIN-1	BOLT (六角螺栓)	3	
02-52	TR-670R-FN.N-M8-DIN-1	NUT (螺母)	3	
02-53	TR-670R-FN.B-M10x25-8.8-DIN-1	BOLT (六角螺栓)	4	
02-54	TR-670R-80-0998	LOCK WASHER (锁紧垫圈)	1	

# TR-670R-03 GUIDE CYLINDER & SPRING ASSY

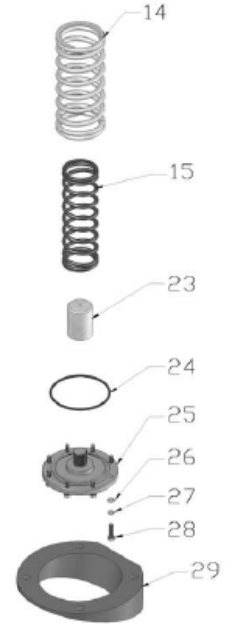
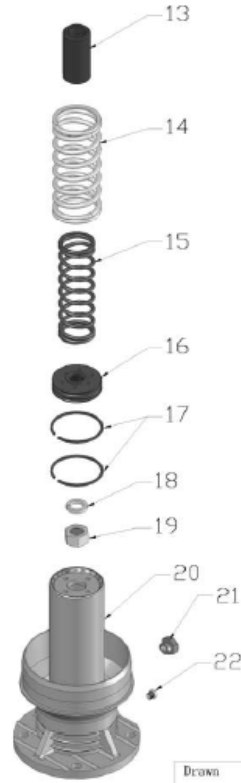

Drawn	C. J	Model	TR-670R	Drawing No.	TR-670R-03
Checked		Description	GUIDE CYLINDER & SPRING ASSY		
Approved		Date	2009. 11. 10		

# TR-670R-03 GUIDE CYLINDER & SPRING ASSY

NO. 序号	PART NO. 图号	PART DESCRIPTION 品名	QTY 数量	UNIT PRICE (EUR)
03-1	TR-670R-65ND-020228	PISTON ROD (活塞杆)	1	
03-2	TR-670R-70B-020215	PISTON PIN (连接销)	1	
03-3	TR-670R-CS.RG16	EXTERNAL CIRCLIP (轴用挡圈)	2	
03-4	TR-670R-W04-124.4x3.1	O RING (O型圈)	1	
03-5	TR-670R-HHOS.B-M20x1.5	HEXAGON HEAD PLUG (六角螺塞))	1	
03-6	TR-670R-GB97.1-M20	CUPRUM WASHER (铜垫圈)	1	
03-7	TR-670R-65ND-020400	GUIDE CYLINDER (TOP) (上筒)	1	
03-8	TR-670R-FN.W12-DIN-1	WASHER (平垫)	4	
03-9	TR-670R-SPG.W12-DIN-1	SPRING WASHER (弹垫)	4	
03-10	TR-670R-HS.B-M12x45	SCREW (内六角螺栓)	4	
03-11	TR-670R-70B-021000	BELLOW HOOP (抱箍)	2	
03-12	TR-670R-70B-020216	BELLOW (皮老虎)	1	
03-13	TR-670R-70B-020219	SPRING GUIDE (MIDDLE) (轴套)	1	
03-14	TR-670R-70B-020202	OUTTER SPRING (大弹簧)	2	
03-15	TR-670R-70B-020201	INNER SPRING (小弹簧)	2	
03-16	TR-670R-70B-020210	PISTON (活塞)	1	
03-17	TR-670R-70B-020211	PISTON RING (活塞环)	2	
03-18	TR-670R-SPG.W22-DIN-1	SPRING WASHER (弹垫)	1	
03-19	TR-670R-FN.N-M22x1.5-DIN-3	NUT (硬螺母)	1	
03-20	TR-670R-65ND-020500	GUIDE CYLINDER (BOTTOM) (下筒)	1	
03-21	TR-670R-100GB-041000	OIL GAUGE (油标)	1	
03-22	TR-670R-HSHOS.B-G1/8	HEXAGONAL SOCKET HEAD PLUG (内六角螺塞)	1	
03-23	TR-670R-70B-020223	SPRING GUIDE (BOTTOM) (套)	1	
03-24	TR-670R-W04-90x3.5	O RING (O型圈)	1	
03-25	TR-670R-65ND-020225	FLANGE (下盘)	1	
03-26	TR-670R-FN.W6-DIN-1	WASHER (平垫)	8	
03-27	TR-670R-SPG.W6-DIN-1	SPRING WASHER (弹垫)	8	
03-28	TR-670R-FN.B-M6x25-8.8-DIN-1	BOLT (六角螺栓)	8	
03-29	TR-670R-70B-030102	FOOT PLATE (底座)	1	

# TR-670R-04 RAMMER SHOE ASSY

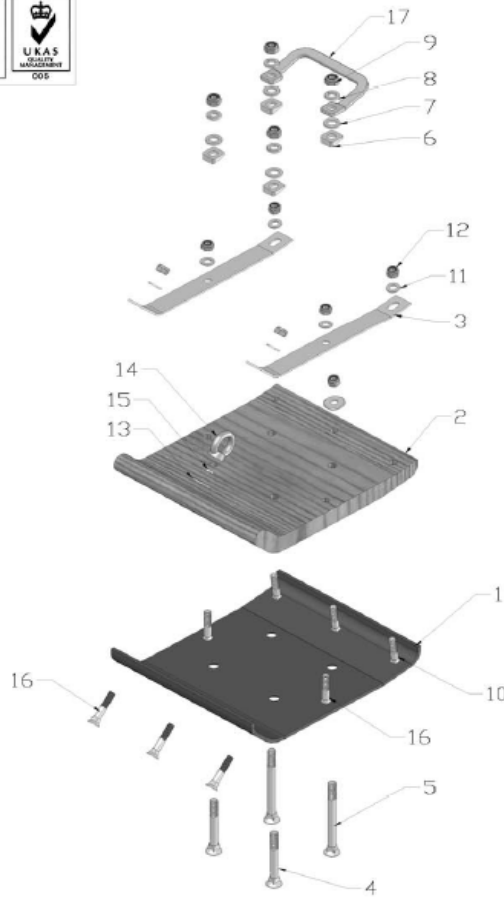

Drawn	C. J	Model	TR-670R	Drawing No.	TR-670R-04
Checked		Description	RAMMER SHOE ASSY		
Approved		Date	2009. 11. 10		

NO. 序号	PART NO. 图号	PART DESCRIPTION 品名	QTY 数量	UNIT PRICE (EUR)
04-1	TR-670R-70B-030105	RAMMER SHOE STEEL PLATE (铁底板)	1	
04-2	TR-670R-70B-030104	RAMMER SHOE WOODEN PLATE (木底板)	1	
04-3	TR-670R-70B-030101	RAMMER SHOE CLAMP PLATE (压条)	2	
04-4	TR-670R-FSN.B-M12x95	SUNK HEAD BOLT (沉头方颈螺钉)	2	
04-5	TR-670R-FSN.B-M12x130	SUNK HEAD BOLT (沉头方颈螺钉)	2	
04-6	TR-670R-70B-030103	WASHER (斜垫块)	4	
04-7	TR-670R-FN.W12-DIN-1	WASHER (平垫)	4	
04-8	TR-670R-SPG.W12-DIN-1	SPRING WASHER (弹垫)	4	
04-9	TR-670R-IN.N-M12-DIN-1	LOCK NUT (防松螺母)	4	
04-10	TR-670R-FSN.B-M10x50	SUNK HEAD BOLT (沉头方颈螺钉)	3	
04-11	TR-670R-FN.W10-DIN-1	WASHER (平垫)	6	
04-12	TR-670R-IN.N-M10-DIN-1	LOCK NUT (防松螺母)	7	
04-13	TR-670R-WOD.W10-DIN-1	LARGE WASHER (大垫圈)	2	
04-14	TR-670R-EYE.N-M10	EYE NUT (吊环螺母)	1	
04-15	TR-670R-SPG.W10-DIN-1	SPRING WASHER (弹垫)	1	
04-16	TR-670R-FSN.B-M10x55	SUNK HEAD BOLT (沉头方颈螺钉)	5	
04-17	TR-670R-65ND-030100	HANDLE (把手)	1	