

# ROAD MASTER 900K

---



## OPERATING & MAINTENANCE MANUAL



# Ride-On Vibratory Roller

---

# EC DECLARATION OF CONFORMITY / DECLARATION CE DE CONFORMITE / DECLARACIÓN DE CONFORMIDAD CE / DECLARAÇÃO CE DE CONFORMIDADE

GB/US

We, **Uni-corp Europe, 33 Avenue Pierre Brossolette, 94048 Créteil Cedex, France**, hereby certify that if the product described within this certificate is bought from an authorised Paclite dealer within the EEA, it conforms to the following directives: Machinery Directive 2006/42/EC, Electromagnetic Compatibility Directive 2004/108/EC (as amended by 92/31/EEC & 93/68 EEC). The physical agent (vibration) conforms with the directive 2002/44/EC. The low voltage directive 2006/95/EC, BS EN ISO 12100-1/2 Safety of machinery and associated harmonised standards, where applicable. Noise emissions conform to directive 2005/88/EC Annex VI), for machines under article 12 the notified body is **TÜV Rheinland Product Safety GmbH - Am Grauen Stein - D-51105 Köln, Germany**.

F

Nous soussignons, **Uni-corp Europe, 33 Avenue Pierre Brossolette, 94048 Créteil Cedex, France**, certifions que si le produit décrit dans ce certificat est acheté chez un distributeur de la marque déposée "Paclite" au sein de la EEA, celui-ci est conforme aux norms CEE ci-après: Norme de la machine 2006/42/CE, Norme compatible pour l'électromagnétisme 2004/108/CE (modifié par 92/31/CEE et 93/68/CEE). Le nombre de vibrations est en accord avec la directive 2002/44/CE. Caractéristiques basse tension 2006/95/CEE, BS EN ISO 12100-1/2, Norme de sécurité des machines et des critères associés et configurés, si applicable. Les émissions de bruit sont conformes à la directive 2005/88/CE Annexe VI pour machines, article 12. L'objet mentionné est **TÜV Rheinland Product Safety GmbH - Am Grauen Stein - D-51105 Köln, Allemagne**.

E

La Sociedad, **Uni-corp Europe, 33 Avenue Pierre Brossolette, 94048 Créteil Cedex, France**, por el presente documento certifica que si el producto descrito en este certificado es comprado a un distribuidor autorizado de Paclite en la EEA, este es conforme a las siguientes directivas: 2006/42/CE de la CEE, Directiva 2004/108/CEE sobre Compatibilidad Electromagnética (según enmiendas 92/31/CEE y 93/68 CEE). El numero de vibraciones esta de acuerdo con la Directiva 2002/44/CE. Directiva sobre Bajo Voltaje 2006/95/CEE, BS EN ISO 12100-1/2 de Seguridad de Maquinaria y Niveles armonizados estándares asociados donde sean aplicables. Emisión de Ruidos conforme a la Directiva 2005/88/CE Anexo VI para máquinas bajo articulo 12 la mencionada unidad está **TÜV Rheinland Product Safety GmbH - Am Grauen Stein - D-51105 Köln, Germany**.

P

O signatário, **Uni-corp Europe, 33 Avenue Pierre Brossolette, 94048 Créteil Cedex, France**, pelo presente, declara que se o produto descrito neste certificado foi adquirido a um distribuidor autorizado do Paclite em qualquer país da EEA, está em conformidade com o estabelecido nas seguintes directivas comunitárias: 2006/42/CE, Directiva de Compatibilidade Electromagnética 2004/108/CEE (conforme corrigido pelas 92/31/EEC & 93/68 EEC). O numero de vibrações está de acordo com a directiva 2002/44/CE LB. A directiva de baixa voltagem 2006/95/CEE, BS EN ISO 12100-1/2 Segurança da maquinaria e às normas harmonizadas afins se aplicáveis. As emissões de ruído respeitam e estão dentro das directivas para máquinas 2005/88/CE Anexo VI, artigo 12, sendo o organismo notificado **TÜV Rheinland Product Safety GmbH - Am Grauen Stein - D-51105 Köln, Germany**.

PRODUCT TYPE.....	TYPE DE PRODUIT....	TIPO DE PRODUCTO..	TIPO DE PRODUCTO..
MODEL.....	MODELE.....	MODELO.....	MODELO.....
SERIAL No.....	Nº DE SERIE.....	Nº DE SERIE.....	Nº DE SÉRIE.....
DATE OF	DATE DE	FECHA DE	DATA DE
MANUFACTURE.....	FABRICATION.....	FABRICACIÓN.....	FABRIC.....
WEIGHT.....	POIDS.....	PESO.....	PESO.....



Signed by:   
Signature:

**Anita Tan**

Quality Manager - On behalf of Uni-corp Europe  
Directrice de Qualité - au nom de Uni-corp Europe S.A.R.L.

## FOREWORD

This manual has been written to help you to operate the Roller Series safely. This is intended primarily for dealers and operators of Paclite Road Master vibrating roller. It is recommended that you keep this manual or a copy of it with the machine so that it is readily available for reference.

Before you operate or carry out any maintenance on this machine YOU MUST READ and UNDERSTAND this manual.

If you have ANY QUESTIONS about the safe use or maintenance of this machine after reading this manual, ASK YOUR SUPERVISOR or CONTACT:  
Uni-corp Europe on +33 (0) 1 4981 6955

Paclite reserves the right to change machine specification without prior notice or obligation.

### Directions with regard notations

Text in this manual to which special attention must be paid are shown in the following way:



**CAUTION**

This CAUTION sign indicates a potential hazard, which if ignored, could result in injuries to the operator and/or those close by, as well as damaging the machine.



**WARNING**

This WARNING sign indicates a potential hazard, which if ignored could result in the DEATH of the operator and/or those close by.

# CONTENTS

## Foreword

### 1.0 SAFETY INFORMATION:

1.1 Operational Safety	1
1.2 Service Safety	2
1.3 Fuel Safety	3
1.4 Health & Safety	3
1.5 PPE (Personal Protective Equipment)	4
1.6 Environment	4

### 2.0 MACHINE DETAILS:

2.1 Machine Plate	5
2.2 Engine Plate	5
2.3 Labels	6-7
2.4 Control Panel and locations	8
2.4.1 Gauges	8
2.4.2 Indicator lamps	8
2.4.3 Switches	9-10
2.5 Roll Over Protection Structure (ROPS)	11
2.6 Beacon Light	12
2.7 Backup Alarm	12
2.8 Seat Belt	12
2.9 Driver Presence System	12
2.10 Scrapper Adjustment	12
2.11 Electrical System	13

### 3.0 OPERATION:

3.1 Before Starting the Engine	13
3.2 Starting the Engine	13
3.3 After Starting the Engine	14
3.4 Speed Control	14
3.5 Operation on Slopes	15
3.6 Vibratory Operation	16
3.7 Sprinkler System	16
3.8 Stopping /Parking	17
3.9 Long term Parking	17
3.10 Lifting the Machine	17
3.11 Towing the Vehicle	18
3.12 Transporting the Machine	19

<b>4.0 MAINTENANCE</b>	
4.1 Engine maintenance Schedule	20
4.2 Periodic maintenance	21-22
4.3 Sprinkler System-Checking & Cleaning	23
4.4 Hydraulic system	23-24
4.5 Grease Fitting	25
4.6 Electrical System	25-26
<b>5.0 TROUBLE SHOOTING</b>	27
<b>6.0 TECHNICAL DATA</b>	28
6.1 Machine Dimension	29

## 1.0 Safety Information

For your own personal protection and for the safety of those around you, please read and ensure you fully understand the following safety information.



Improper maintenance can be hazardous. Read and understand this section before you perform any operation, maintenance, service or repairs.

### 1.1 Operational Safety

- The owner of this machine must observe, and also train the user of the machine to observe, the effective labour protection laws in the country of application.
- Use suitable lifting equipment to lift the machine.
- This machine is only be used for its intended application.
- Well-trained personnel must only operate this machine.
- Personal Protective Equipment (PPE) must be worn by the operator whenever the equipment is being used.
- Cordon off the work area and keep members of the public and unauthorized personnel at a safe distance
- DO NOT drive over curbs or uneven surfaces that will result in the machine and operator being shaken.
- DO NOT start the machine when standing alongside it. Start the engine when seated in driver's seat and with forward/ reverse control lever in neutral position.
- During use; the engine, coolant, engine oil, and hydraulic oil become hot. Perform all the work such as removing the filler caps, draining the oil or replacing the filter in accordance with the correct procedures after the machine cooled down.
- Never leave the engine running and unattended.
- Always ensure filler caps of fuel and oil tanks are tight.
- DO NOT smoke or use a match/cigarette lighter during the operation and refueling.
- NEVER carry passengers on this machine.
- Keep clear of the articulated joint between the front and rear frames.
- DO NOT try to get on or off moving machine.
- Be aware of the changing positions, movement of other equipment and personnel in the job site.
- DO NOT attempt to shift speeds while traveling on a grade. While moving uphill or downhill run at low speed.

- Always switch OFF the engine before transporting , moving around site or servicing it.
- Be cautious when operating the machine near the edges of pits, trenches and platform.
- During nighttime; carefully drive the machine at a speed suited to illumination. Keep the head lamps lightened. Provide extra lighting in the work area if found necessary.
- Keep hands, feet and loose clothing away from the moving parts of the machine.
- Operate the machine with all safety devices and guards in place and in working order.
- If the surface to be compacted is on a slope, take great care when controlling the roller's direction of travel. Always work up and down a slope; not across.
- Do not operate the machine when you are ill, feeling tired or when under the influence of alcohol or drugs.
- When parking the machine, select level and hard ground. If necessary to park on a slope, block the front of the drums on the down side of the slope.
- This machine is designed to eliminate the possible risks arising from the use of it. However, risks DO reside, and these residual risks are not clearly recognizable and may cause personal injury or property damage, and possibly death. If such unpredictable and unrecognizable risks become apparent, the machine must be stopped immediately, and operator or his supervisor must take appropriate measure to eliminate such risks. It is sometimes necessary that the manufacturer must be informed of such event for future counter measuring.

## **1.2 Service Safety**

- Use proper warning tags when servicing the machine.
- Always make ensure proper tooling is used for servicing.
- Do not modify the machine with out approval of manufacturer
- Avoid standing under the machine while it is being hosted or moved.
- Do not open the hydraulic lines or loosen the hydraulic connections while engine is running pressure should be bled from the hydraulic circuit before dismantling the hydraulic connectors.
- Always check and maintain the external fasteners.
- While checking the coolant level always shutdown the engine and allow the engine and radiator to cool down.
- Keep the area near muffler free of debris to avoid fire hazards.
- When repairing electrical system, disconnect the negative cable from the battery to shut off electric power.
- Be careful while inspecting or servicing the fan or belt in motion.
- Make sure hose connection have been reconnected back to the correct fitting. Failure to do so may result in damage to the machine or injury to the person.

- Make sure articulation joint is locked before lifting, jacking and servicing the machine in order to avoid unexpected swinging of machine halves.
- Drain the oil from the machine into a proper container. Do not drain directly on the ground. Obey all local, state and federal environment regulation for proper disposal of fuel, oil, coolant, battery electrolyte or any other fluids.
- Before starting the machine ensure all the tools have been removed from the machine and the replacement parts are firmly tightened.
- Keep the machine clean and labels legible. Replace missing and hard to read labels.
- Perform periodic maintenance as recommended in operators manual.

### 1.3 Fuel Safety



**WARNING**

Fuel is flammable. It may cause injury and property damage. Shut down the engine, extinguish all open flames and do not smoke while filling the fuel tank. Always wipe up any spilled fuel.

- Before re-fuelling, switch off the engine and allow it to cool.
- When re-fuelling, use a proper funnel, and avoid spilling over the engine.
- When re-fuelling, DO NOT smoke or allow naked flames in the area.
- Spilt fuel must be made safe immediately by using sand. If fuel is spilt on your clothes, change them.
- Store fuel in an approved, purpose made container away from heat and sources of ignition.

### 1.4 Health & Safety

#### **Vibration**

Some vibration from the compacting operation is transmitted through the handle to the operator's hands. Ensure operator rotation and do not exceed the maximum recommended usage times.

#### **Dust**

The compaction process can produce dust, which may be hazardous to your health. Always wear a mask that is suited to the type of dust being produced.

#### **Fuel**

Do not ingest fuel or inhale fuel vapors and avoid contact with your skin. Wash fuel splashes immediately. If you get fuel in your eyes, irrigate with copious amounts of water and seek medical attention as soon as possible.



## Exhaust Fumes

Do not operate the Ride-on Roller indoors or in confined spaces. Make sure the work area is adequately ventilated.

### 1.5 PPE (Personal Protective Equipment)

Suitable PPE must be worn when using this equipment i.e. safety goggles, gloves, ear defenders, dust mask and steel toe-capped footwear (with anti-slip soles for added protection). Wear clothing suitable for the work you are doing.



### 1.6 Environment

- In order to protect the environment please recycle any discarded apparatus or accessories.
- Use leak proof containers when draining fluids.
- Do not pour the waste in to the ground, down a drain or into water source.



## 2.0 Machine Details

### 2.1 Machine Plate

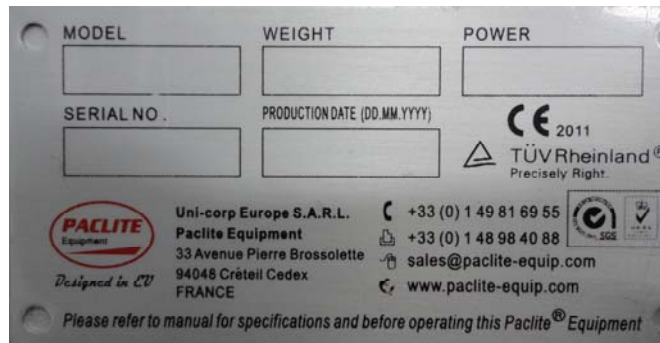





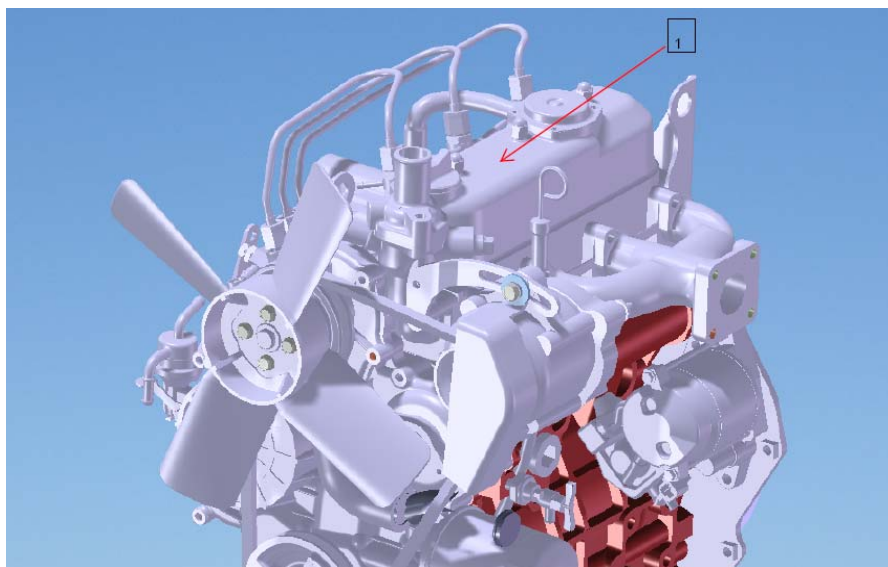

The machine plate is attached to the machine. It consists of model code, weight, serial number, power of the engine and production date.

### 2.2 Engine Plate:



The location 1 shows the details of engine serial number and code number. Specify the serial number when ordering the parts. Refer also to the engine manual.

## 2.3 Labels

<b>Labels</b>		
<b>Symbol</b>	<b>Details</b>	<b>Location</b>
	Vibration	Control Panel
	Engine Throttle	Control Panel
	Emergency Stop	Control Panel
	Hazardous Gas Warning	Near Exhaust outlet
	Personal Protective Equipment	Control Panel Side
	Belt	Bonnet Side
	Lifting Hook	Near four lifting points

	Water	Near Water Tank Cap
	Engine Oil Drain	Lower right Corner of Front Frame.
	Pinch Pint hazard warning	Lower side of back Frame
	Hot Surface-Caution	Bonnet
	Machine Specification	Back Frame
	Machine name decal	Lower side of front frame
	Machine Logo	In the bonnet-Front Front frame-Side Rear Frame-back

## 2.4 Control Panel and locations

For safe operation of this machine, it is very important to understand the function of each system.

### 2.4.1 Gauges

**Fuel Gauge:** This gauge indicates the level of fuel in the tank.

E: - Tank is empty

F: - Tank is full

**Hour meter:** The hour meter shows total operating hours.

### 2.4.2 Indicator lamps:

**Vibration Indicator:** When the vibration switch in the control lever is operated this lamp will illuminate. This indicates drum vibration is ON.



**Glow plug indicator:** This light goes on when the ignition switch is turned to IGN&ACC.



**Low oil pressure indicator:** This warning light illuminates when the ignition switch is in on position and the engine is not running. When the engine starts, it goes off. If this light illuminates when the engine is running, it indicates that the oil pressure is low. Do not operate the machine if this light is illuminated.



**Air Filter indicator:** This lamp glows when the air filter has to be removed.



**Battery indicator:** This indicator light illuminates when the battery is not charging.



**Parking Brake Indicator:** This lamp glows when the parking brake is engaged.



### 2.4.3 Switches

#### Ignition Switch

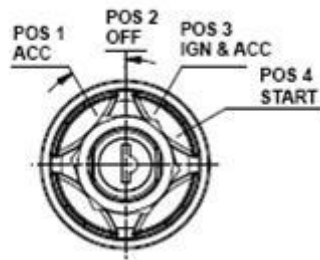

- This switch starts and stops the engine.
- ACC: Accessories switch. If the key is turned to this position, the lamp circuit is charged with electricity.
- OFF: the key can be removed in this position. All the electric systems are switched off. To shut down the engine move the key to this position
- IGN&ACC: The charging and lamp circuit are charged with electricity. The glow plug will switch on at this position; Stay in this position until the lamp goes off. Turn the key to START position to start the engine
- START: the engine is cranked and gets started. The moment engine has started release the key.

#### Lamp Switch

This switch is used to ON and OFF the headlamps. The symbol below denotes the headlamp switch.



### **Turn Signal Switch (Optional)**

Turn signal lamps will flash when the lever is operated.

Left Turn: Move the lever forward

Right turn: Move the lever backward

### **Parking brake Switch**

If this switch is pressed down, the parking brake applies. If the parking brake is in engaged the parking indicator lamp in the control panel glows. To release the parking switch rotate the switch in to clockwise direction.

### **Horn Switch**

Pressing the button at the center of the steering wheel makes the horn sound.

### **Springler Switch**

This switch is being used to switch ON and OFF the Springler pump.

ON : Sprinkling is performed.

OFF : Sprinkling is shutoff.

### **Vibration Intitation Switch**

In order to start the vibration the vibration Initiation switch has to be applied. This switch is situated in control lever. The vibration continuous to work unless the engine is shut down or vibration initiation switch is shifted to OFF position.

### **Vibration Mode Switch**

This switch allows to select between single and double drum vibration.

I Front Drum vibration only

II Double Drum Vibration

### **Throttle Switch**

This switch regulated engine RPM. Two modes of engine RPM selection are available.

HIGH In this mode, Engine RPM will be high

LOW In this mode, Engine RPM will be low

## 2.5 Roll Over Protection Structure (ROPS):

- This machine equipped with Roll Over Protection System to protect the operator when the roller is used in slopes, open trenches, sharp turns and objects in the rollers path.
- Before using the machine, position the ROPS in the upright position. In order to do so, use a crane or suitable rigging capable of supporting the frame. Remove the safety pin and pull out the locking pin. Lift the ROPS in upright position. Insert the locking pin and secure with safety pin.
- To lower the ROPS; support the upper frame with suitable rigging .Remove the safety pin and pull out the locking pin(1) on both sides. Slowly lower the upper frame. While lowering do not allow the upper frame to fall this will weaken the ROPS system. Insert the pins in the ROPS in the lower hole setting through the upper frame to secure.
- ROPS should check regularly for rust, cracks and other damages.
- ROPS should be in upright position whenever using the machine. If the ROPS is removed from the machine, it must be reinstalled before the machine is used. While reinstalling, ensure to tighten the bolts to specified torques.
- Do not modify the ROPS in any form.

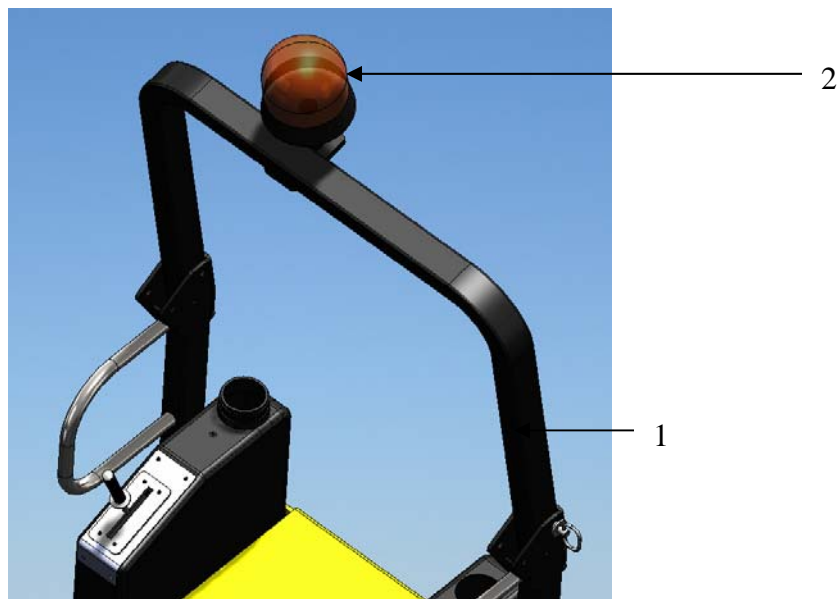



The beacon powers up when the ignition switch is turned to ON position

To install the beacon light (2), slide the beacon light in to light staff. After that, tighten the wing nut on the base of light.

## 2.7 Backup Alarm

The alarm is situated in the rear of machine. When control lever is moving in reverse direction this alarm, will sound. The back up alarm will continue to sound until the control lever is moved to neutral position or to the forward position.

## 2.8 Seat Belt

To engage the seat belt; pull the belt out of the retractor continuously. Fasten the set belt catch into buckle. The retractor will adjust the belt length and retractor will lock in place. To release the seat belt, push the release button on the buckle.



## 2.9 Driver Presence System

- This machine is equipped with driver presence switch in the seat. If the operator not in the seat the machine will not drive. If the operator leaves from the seat, the brakes will be applied.
- While the machine is in operation, do not change the position of the driver. The Driver presence system will prevent all machine movements if the operator is not present in the seat.
- If the roller is supplied with an adjustable seat, adjust the distance from the seat to driving controls.

## 2.10 Scrapper Adjustments:

To prevent sticking the dirt and asphalt on the drum surface two-scrapper bars are provided in each drum. These scrappers are spring loaded.

## **2.11 Electrical System**

- Fuse Box: When changing the fuse cut the power supply.
- Fuses protect electrical components and wiring from burning. To replace fuses, take off cover. Ensure fuses are of correct capacity.

## **3.0 OPERATION:**

- Operate the machine from the operator's seat.
- Check the steering lock arm is in the unlocked position .Removed lock pin should be installed to the round pipe at the front right of the rear frame.
- Check that the Control lever is in neutral position.

### **3.1 Before Starting the Engine:**

Check the following

- Engine oil level
- Engine Coolant
- Hydraulic Fluid Level
- Fuel Level
- Water level
- Scrapper Bars
- hydraulic hoses and fuel Line
- Warning lamps

### **3.2 Starting the Engine:**

- Set the control lever in neutral position
- Sit down in the operators seat and fasten the seat belt
- Make sure vibration switch has been turned off.
- Release the Parking brake.
- Turn the ignition switch to ON position. The glow plug indicator will illuminate. After the glow plug lamp goes out; start the engine.
- The ignition switch has anti- restart option. If the engine doesn't start the switch will need to be turned to the OFF position before it will allow the engine to be ranked again.

## **IMPORTANT:**

- Do not allow the starter key to stay in the START position for more than 15 Seconds.
- If the engine does not start, allow an interval before next trial.
- Check the warning lamps on the control panel. If any of the lamps seems to be malfunctioning while starting or running, stop the machine, identify the problem and rectify it.

### **3.3 After Starting the Engine:**

- Run the engine for few minutes to warm it up. This allows the lubricating oil to reach the vital parts of the engine and hydraulic system.
- Check for the Colour of exhaust gas; listen for unusual sounds and vibration. If abnormal, determine the cause and correct the problem.

### **3.4 Speed Control:**

- The control lever is used to control the direction and speed of the machine. Use the lever rather than the throttle, to control the speed of the machine, which is in operation.
- The traverse of control lever determines the speed and direction of the machine
- Avoid abrupt operation of control lever
- During operation run the machine at full throttle to ensure the maximum travel speed and best compaction.
- Give Extreme attention to the area behind the machine when reversing.
- Speed is same for forward and reverse direction.
- In order to change the direction move the control level to neutral position, this allows the vehicle to come to a complete stop, and then move the control lever to desired position.

### 3.5 Operation on Slopes

- When operating on slopes care must be taken to avoid accidents and damage to the equipment. Always operate the machine up and down rather than from side to side. For safe operation and for protection of the engine, continuous duty may be restricted to front /rear slope of 17° or less
- Do not operate this machine on side slope. The machine may roll over even on stable ground



**Machine on slope**

### 3.6 Vibratory Operation:

- The push button switch in the control lever is being used to switch ON and OFF the vibration.
- The vibration ON indicator will light when vibration is switched ON and will remain until it is switched OFF.
- Select the vibration mode either front or dual drum vibration by pressing the switch in the control panel.
- Vibration can be turned on while operating either forward or reverse and will remain until it is turned off.

- When operating on asphalt and in order to keep the surface finish smooth, turn the vibration off before stopping the roller.
- Keep the vibration shut off when the machine is not rolling
- Stop the vibration if the machine has encountered any difficulty during operation.

### **3.7 Sprinkler System**

- A diaphragm pump is used to feed the water from tank to the Sprinkler tubes.
- Sprinkler switch in the control panel is used to control the water.
- Before sprinkling check for the water level in the sprinkler tank.
- Use clean water.
- Pay attention to the water level in the tank. If the pump operates with tank empty, this will cause the diaphragm pump failure.
- During the winter, fully drain the sprinkler tank, pump, sprinkler tubes, filter and waterline in order avoid damage.
- To drain the water remove the drain cap which is located near rear scrapper.

### **3.8 Stopping /Parking**

- Stop the machine on a flat surface with suitable load bearing capacity
- Before stopping the machine always, switch off the vibration by pressing the vibration switch ON/OFF button in the control lever.
- Set the control lever in the neutral position
- Return the engine throttle to low by pressing the throttle switch.
- Do not bring the hot engine to a sudden stop except for an emergency. Allow the engine to cool gradually.
- Apply the parking brake by pressing down the parking switch. Always set the parking brake before leaving the machine.

- Avoid parking on a grade. If the machine must be parked on a slope surface, choke the drums with wedges to prevent any vehicle movement.
- Perform the walk around checks for oil and water leakage or other abnormalities.
- Fill the fuel tank if necessary.
- Remove all the debris from the engine compartment to avoid possible fire hazard.

### **3.9 Long term Parking**

- Clean the machine and touch up the paint finish to avoid rusting
- Treat the exposed parts with ant- rust coatings and lubricate all the machine parts.
- Engine: Refer to the Kubota manual for further details
- Battery: Remove the battery from the machine. Clean and grease the cable connectors.
- Air cleaner and Exhaust pipe: Cover the inlet of air cleaner and exhaust pipe inlet with plastic or tape in order to avoid the moisture to enter in the engine.
- Drain the water tank completely. Drain water from hoses, water lines and diaphragm pumps.
- Hydraulic system: Fill the hydraulic reservoir to the maximum level.
- Steering Cylinder: Grease the steering cylinder.
- Cover the machine with tarpaulin and if possible keep the machine indoor.

### **3.10 Lifting the Machine:**

- Turn the steering wheel to straight ahead position
- Switch off the engine and push the parking brake switch.
- Pull out the locking pin from the holder, lock the front, and back frame.
- Use four hooking positions (1) to lift the machine.

- Make sure that lifting hoists are properly secured.
- Make sure the vicinity of lifting is cleared off.

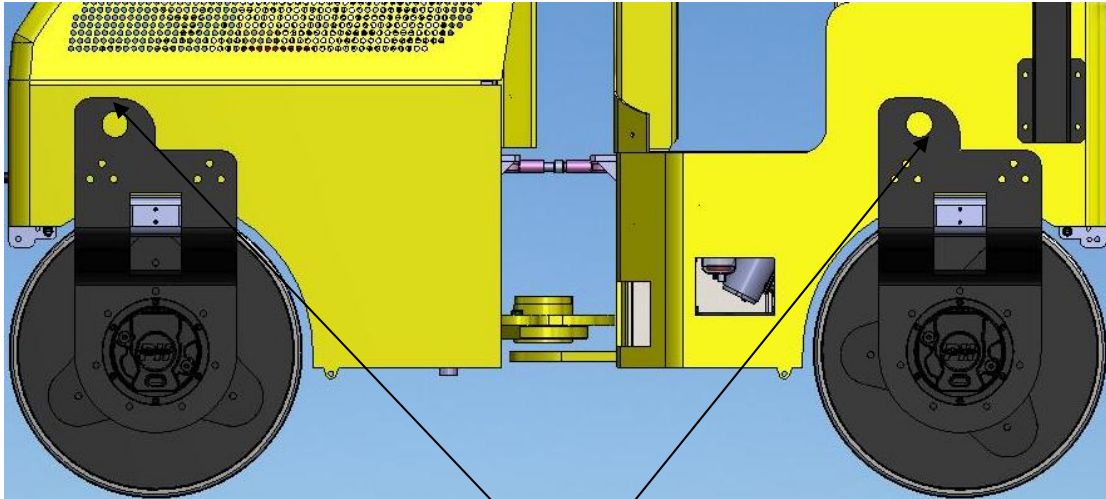

1

### 3.11 Towing

- A towing connection must be used for the purpose. Make sure that the connection is in good condition.
- The towing speed should be very low.

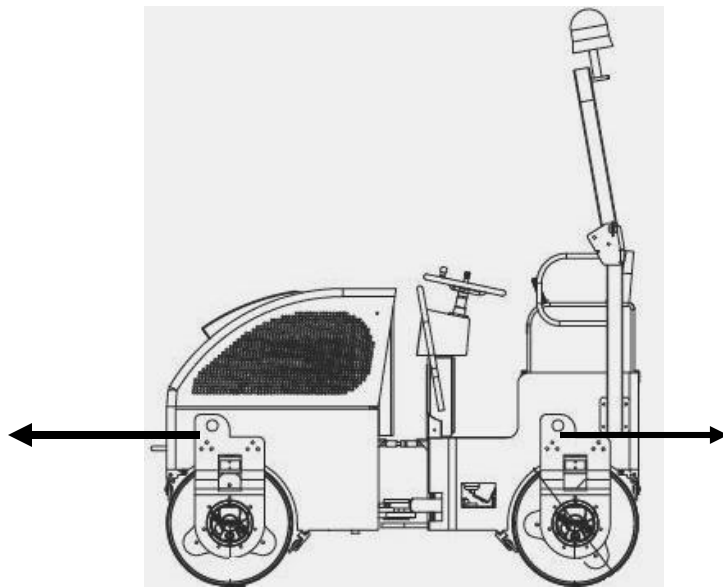

- The towing device must be connected to two lifting points. The pulling force should act longitudinally as shown the picture.

### **3.12 Transporting the Machine**

- Preparations: To transport the vehicle chock the drum and secure the chocks to the drums.
- Ensure the articulation joint is locked by the pin.



## 4.0 Maintenance

<b>4.1 ENGINE MAINTENANCE SCHEDULE</b>					
<b>Kubota</b>	<b>Daily Check</b>	<b>Every 50 Hrs</b>	<b>Every 100 Hrs</b>	<b>Every 200 Hrs</b>	<b>Every 500 Hrs</b>
Fuel Level Check	●				
Engine Oil Level Check	●				
Air Filter Check					
Engine oil and Filter Change		●			
Check for fuel pipes and clamp bands		●			
Air cleaner Cleaning			●		
Fuel Filter Cleaning			●		
Fan Belt tightness Check			●		
Draining water separator			●		
Spark plug Cleaning			●		
Battery Electrolyte level check			●		
Check of intake air line				●	
Oil filter Cartridge change				●	
Check for radiator hoses and clamp bands				●	
Removal of sediments in fuel tank					●
Cleaning of Water jacket					●
Replacement of fan belt					●
*Service more frequently in dusty Conditions * For Further Details please see Kubota Engine Manual					

## 4.2 Periodic maintenance

INTERVAL	ITEM	SERVICE	PROCEDURE
Daily	External Hardware	Visual Verification for external structures	Walk around the vehicle and visually check
	Fuel Tank	Check the fuel level and add as necessary	Check the fuel level
	Radiator	Check for coolant level	Check if the coolant level in the reserve bottle is between low and high
	Fan belt	Check the looseness	Stop the engine and remove the key. Apply moderate thumb pressure to the belt, if tension is incorrect loosen the alternator-mounting bolt and using the lever placed between the alternator and the engine block, pull the alternator out until the deflection of the belt falls within acceptable limits. Replace the belt if it is damaged
	Battery	Check fluid level	Make sure each electrolyte level is to the bottom of vent wells. If necessary add only distilled water in a well-ventilated place
	Hydraulic tank	Check oil level and add as necessary	Check the oil level with the sight glass on the side of the tank.
	Engine Oil	Check the oil Level	Check the engine oil level before starting or more than 5 minutes after stopping the engine

50 Hours	Engine Oil Filter	Replace the oil filter cartridge after the initial 50 hours of operation	Remove the old oil filter cartridge with a filter wrench. Apply a film of oil to the gasket for the new cartridge
100 HOURS	Cylinder Pin	Apply Grease	Grease the fitting using proper tool
250 hours	Engine Oil Pan	Change oil	Remove the drain connector and drain the oil
400 hours	Fuel Pump	Clean Filter	Change the fuel cartridge
	Fuel Filter	Replace the element	Replace the element
	Radiator	Clean fins	If dust is between the fin and tube, wash it away with running water
	Hydraulic tank	Wash inside	Drain the oil by removing the plug. Clean the tank and fill new oil.
As Required	Shock Mounts	Check for deformation	Check the rubber blocks for cracks frequently
	Springler Filter	Clean the Filter	Remove the filter cap and clean the element. Change the element as necessary
	Springler Pipe and nozzle	Clean or replace	Clean Inside the Springler pipe with the pipe cocks and water Springler operated
	Scraper	Clean and adjust	When the gap between the drum and blade become large adjust the scraper properly
	Air Cleaner	Clean the element	Unclip and remove the cover. Remove and clean the element

### 4.3 Sprinkler System- Checking & Cleaning

- Check the holes of sprinkler tube are blocked. Clean when ever necessary.
- Check the water filter for any kinds of blockages. If necessary, remove the filter (1) and clean the filter. The diaphragm pump and water filter is located under the operators platform.

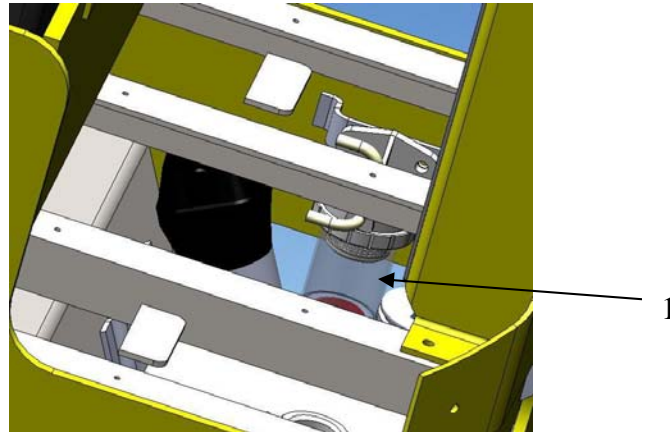

**Diaphragm pump and water filter**

### 4.4 Hydraulic System

- In order to reduce the down time and repairs the hydraulic oil should be clean. While selecting the hydraulic oil specify the anti-wear properties. Avoid mixing different brands and grades of hydraulic oil.
- A hydraulic level sight glass (1) is located on the side of reservoir. After switching off the machine, check the level of oil in the hydraulic tank

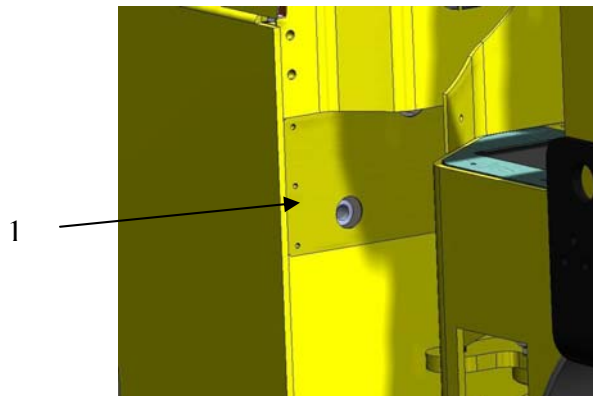

- Check for the leakages in the hydraulic lines
- Hydraulic suction filter is located in the hydraulic tank. Return filter (1) is situated in the top of the hydraulic reservoir

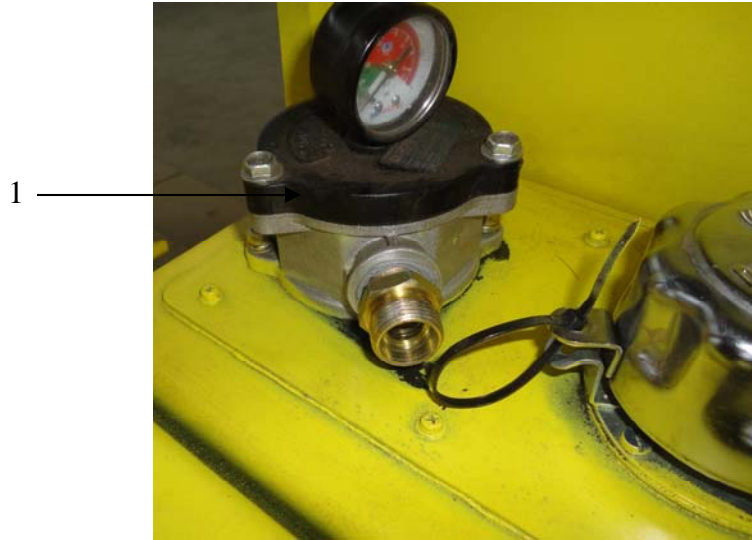

**Return Filter**

- To change the hydraulic oil: remove the hydraulic drain located in the front frame. Unscrew the drain plug (1) and drain the oil.

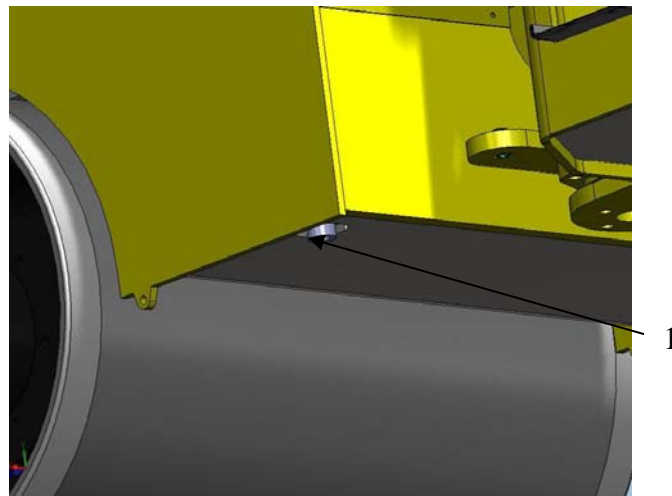

**Hydraulic Drain plug**

## 4.5 Grease Fitting

- **Articulation Joint:**

The articulation joint is being equipped with grease fitting. Before applying the grease make sure the articulation joint is locked by lock pin

- **Front & Rear Drum**

The front and rear drums are equipped with grease fitting.

- **Steering Cylinder**

Grease fittings are provided in the base and rod of the cylinder.

## 4.6 Electrical System:

- The fuse box houses 5A, 10A, 15A, 20A, 50A Fuses. Use fuses of correct capacity
- When the fuse is burned, determine the cause before replacing.
- Leaving the battery unused for long without attention or its power excessively at a time can cause the damage to the plates, leading to a shortened life.
- For long term storage, charge it fully, tighten the caps securely, store in a cool and dry place, and check the level of charge at least once a month

### Battery



**WARNING**

Explosion hazard: Batteries can emit hydrogen gas. Keep all the sparks and flames producing devices away from the battery. Do not short circuit battery post.



**WARNING**

Battery fluid is poisonous and corrosive. Dispose the battery in accordance with corresponding govt. rules and regulations.

To disconnect the battery:

- Stop the machine and shut down the engine
- Place all electrical connection in OFF position
- Disconnect the negative (-ve) battery cable from the battery
- Disconnect the positive(+ve) battery cable from the battery

To connect the battery:

- Connect the positive (+ve) battery cable to the battery
- Connect the (-ve) battery cable to the battery

## 5.0 Trouble Shooting

Problem	Remedy
Engine Does not Start	Check the Fuel tank
	Ensure the fuel used is DIESEL
	Fuel System is not primed
	Check the fuel filter
	Check the battery Connection
	Check Starter motor
	Check the fuel pump
	Check electrical Connection and fuses
	No Vibration
Check the vibration solenoid in the manifold block	
Check exciter assembly	
Check the vibration motors	
Check the hydraulic system and components	
Vehicle not traveling	Check the control cable and lever
	Check the drive motors
	Check the hydraulic brake
	Check the pump solenoid
	Check the hydraulic pump
Steering Not Working	Check steering Cylinder
	Check steering pump
	Check articulation joint



## 6.0 Technical Data

<b>MODEL</b>	<b>ROAD MASTER 900K</b>
<b>WEIGHT</b>	
GROSS WEIGHT	1600 kg
<b>DIMENSION</b>	
LENGTH	2095
WIDTH	980
HEIGHT	1613( Folded ROPS)
<b>PERFORMANCE</b>	
SPEED (FORWARD/REVERSE)	0-10 kmph
Gradability	30%
Vibration frequency	66.7 Hz(4000VPM)
Centrifugal force	16kN
<b>ENGINE SPECIFICATION</b>	
Model	Kubota D1005-E3B-KEA-1
Type	Vertical, water-Cooled, 4-Cycle Diesel Engine
No. of Cylinder	3
Total Displacement	1.123
Brake horse power	18.5 kW/3000rpm
<b>TANK CAPACITY</b>	
Fuel tank	30 Liters
Hydraulic Tank	30 Liters
Sprinkler Tank	110 liters

# 6.1 Machine Dimensions

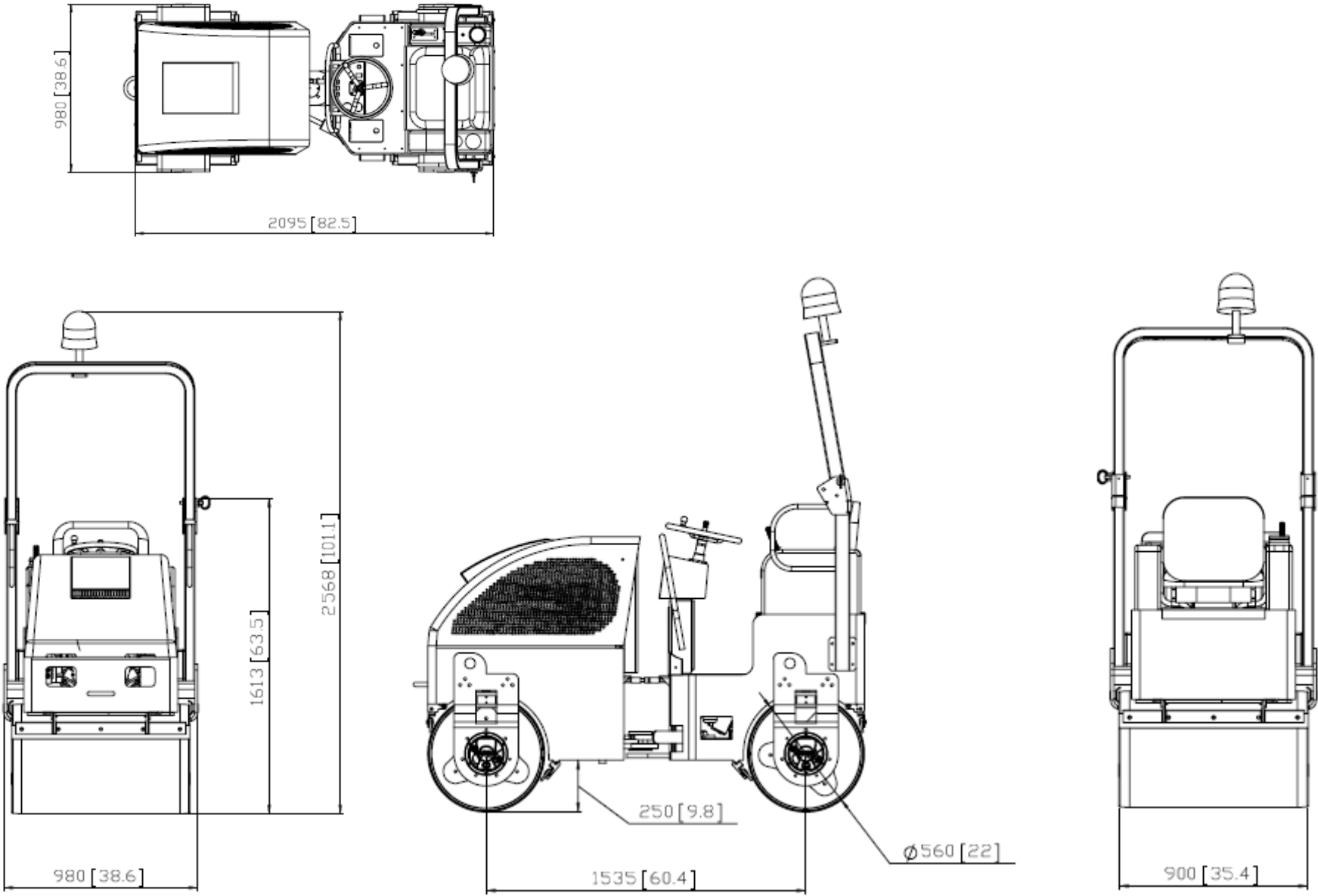





**Uni-corp Europe S.A.R.L.**  
**Paclite Equipment**

33 Avenue Pierre Brossolette,  
94048 Créteil Cedex,  
FRANCE

 +33 (0) 1 49 81 69 55

 +33 (0) 1 48 98 40 88

 [sales@paclite-equip.com](mailto:sales@paclite-equip.com)

 [paclite-equip.com](http://paclite-equip.com)

