

KOHLER® KDW 702 - 1003 - 1404

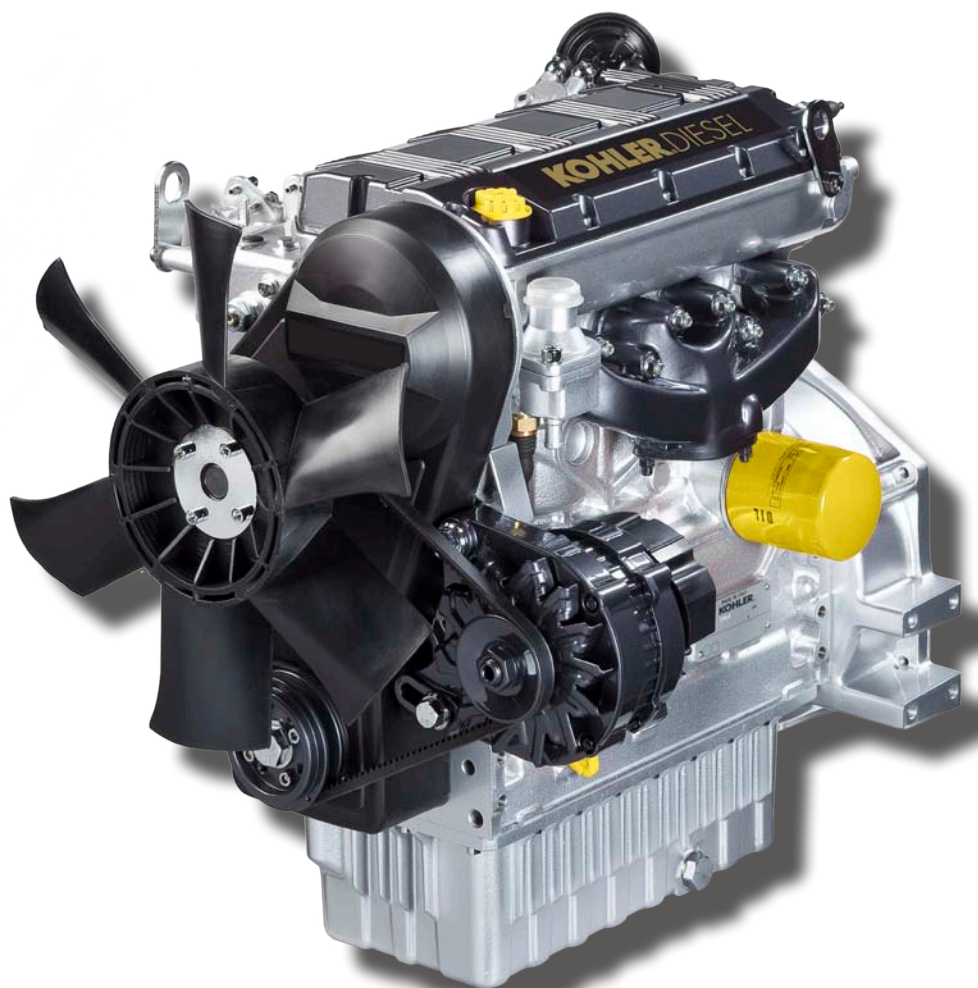

KOHLER
ENGINES



KDW 702 - 1003 - 1404

PREFACE

- Every attempt has been made to present within this service manual, accurate and up to date technical information. However, development on the **KOHLER** series is continuous. Therefore, the information within this manual is subject to change without notice and without obligation. The materials used by **KOHLER** to construct the engine's components undergo strict quality controls and the engine's assembly guarantees reliability and long life. The engine has been built to the machine manufacturer's specifications, and it was its responsibility to adopt all the measures needed to meet the essential health and safety requirements as provided for by the laws in force; use of the engine for uses other than the one defined shall not be considered as compliant with the use intended by **KOHLER**, who therefore refuses all responsibility for any injury arising from such an operation.
- The information contained within this service manual is the sole property of **KOHLER**. As such, no reproduction or replication in whole or part is allowed without the express written permission of **KOHLER**.

Information presented within this manual assumes the following:

- 1 - The person or people performing service work on **KOHLER** series engines is properly trained and equipped to safely and professionally perform the subject operation;
 - 2 - The person or people performing service work on **KOHLER** series engines possesses adequate hand and **KOHLER** special tools to safely and professionally perform the subject service operation;
 - 3 - The person or people performing service work on **KOHLER** series engines has read the pertinent information regarding the subject service operations and fully understands the operation at hand.
- This manual was written by the manufacturer to provide technical and operating information to authorised **KOHLER** after-sales service centres to carry out assembly, disassembly, overhauling, replacement and tuning operations.
 - As well as employing good operating techniques and observing the right timing for operations, operators must read the information very carefully and comply with it scrupulously.
 - Time spent reading this information will help to prevent health and safety risks and financial damage. Written information is accompanied by illustrations in order to facilitate your understanding of every step of the operating phases.

REGISTRATION OF MODIFICATIONS TO THE DOCUMENT

Any modifications to this document must be registered by the drafting body, by completing the following table.

Drafting body	Document code	Model N°	Edition	Revision	Issue date	Review date	Endorsed
CUSE/ATLO <i>M. Primella</i>	ED0053029340	51262	1°	0	20/06/2012	20/06/2012	

This manual contains pertinent information regarding the repair of Kohler water-cooled, indirect injection Diesel engines type **KDW 702-1003-1404**: updated 20/06/2012.

CHAPTER INDEX

1 - MANUFACTURER AND ENGINE IDENTIFICATION 10

 The identification plate shown in the figure can be found directly on the engine.....10

 Approval data.....10

 Name plate for EPA rules applied on rocker-arm cap11

 Compilation example11

2 - GENERAL REMARKS AND SAFETY INFORMATION 12

 California emission control warranty statement13

 Your warranty rights and obligations13

 Explanation of the safety pictograms that can be found on the engine or in the operation
and maintenance handbook14

 Indications regarding the points on the engine where the safety pictograms are placed14

 Limited 3 year kohler® diesel engine warranty15

 General service manual notes.....15

 Glossary and terminology.....15

 Safety regulations16

 General safety during operating phases17

 Safety and environmental impact17

 Trouble shooting18

3 - TECHNICAL INFORMATION18

 Trouble shooting18

 Technical specifications21

 Performance diagrams24

 Overall dimension28

4 - MAINTENANCE - RECOMMENDED OIL TYPE - REFILLING..... 32

 Routine engine maintenance32

 Ordinary maintenance32

 Extraordinary maintenance32

 Lubricant33

 Prescribed lubricant.....34

 Coolant.....35

 Fuel recommendations35

5 - REGULATIONS FOR LIFTING THE ENGINE 36

6 - DISASSEMBLY / REASSEMBLY 37

 Recommendations for disassembling and assembling37

 Recommendations for overhauls and tuning37

 Dry type air filter.....38

 Air restriction switch.....38

 Oil bath air cleaner (on request)38

 Air filter support.....39

 Intake manifold – remote air filter39

 E.G.R. Circuit (Components)40

 E.G.R. Circuit.....41

 Vacuum pump and vacuum pump flange42

 Exhaust manifold42

 Exhaust manifold - engines with egr.....42

 Cooling fan.....43

 Alternator/cooling fan belt drive43

Fuel tank (optional)	43
Flywheel.....	44
Return pulley.....	44
Driving pulley	44
Ringfeder-type rings on kdw 1404	45
Ringfeder-type rings on kdw 1404 - assembly	45
Timing belt cover.....	45
Timing belt / timing pulley arrangement.....	46
Timing belt removal.....	46
Tightening pulley.....	46
Crankshaft timing pulley	46
Camshaft timing pulley	47
Camshaft timing pulley - disassembly/assembly.....	47
Camshaft timing pulley - reference marks.....	47
Camshaft timing.....	47
Camshaft timing - belt reassembly	47
Camshaft timing - belt tightening tool.....	48
Camshaft timing - belt tightening and fastening	48
Valve timing check	48
Valve timing - angles.....	49
Speed governor	50
Speed governor components	50
Governor springs	50
Governor springs for gensets	50
Speed governor - limiting speed governor	51
Speed governor - reassembly	51
Oil pump.....	52
Oil pump - disassembly	52
Oil pump - reassembly.....	52
Rocker arm cover.....	52
Rocker arm cover gasket.....	53
Crankcase vacuum regulator valve	53
Crankcase breather	54
Valve / rocker arm clearance	54
Injection pump control rod	54
Fuel rail	54
Pump/injector unit - non-return valve	55
Pump/injector unit - disassembly.....	55
Rocker arm pivot, dismounting and remounting	56
Camshaft, disassembly	56
Camshaft, journal and housing measurement.....	56
Camshaft journals and housings - dimensions (mm)	57
Camshaft lobe measurement	57
Intake / exhaust / injection camshaft lobe height.....	57
Cylinder head, removal.....	58
Valves	58
Valve stem sealing rings - reassembly	58
Valve springs.....	58
Valve, specifications	59
Valve guides and valve guide housings.....	59
Valve guide insertion	59
Valve seats and housings - dimensions	60
Valve recess and seat sealing width.....	60
Pre-combustion chamber	61
Pre-combustion chamber ring nut removal	61
Pre-combustion chamber, removal.....	61
Pre-combustion chamber, installation	61
Oil pan, removal.....	62
Piston	62
Stop pin rings, dismounting and remounting	62
Piston, disassembly and inspection.....	63
Piston, class.....	63
Piston, weight.....	64
Piston rings - end gaps (mm).....	64
Piston ring, clearance between grooves (mm)	64
Piston ring, mounting order.....	65
Piston, assembly.....	65

Piston clearance	65
Head gasket	66
Cylinder head assembly	67
Cylinder head tightening procedure KDW 1003	67
Cylinder head tightening procedure KDW 1404	67
Connecting rod	68
Big end bearing	68
Connecting rod, weight	68
Connecting rod with bearings and pin	68
Connecting rod alignment	69
Cylinders	69
Cylinder, class	69
Cylinder roughness	69
Central main bearing caps	70
Rear and forward main bearing caps	70
Check the clearances between the bearings and the journal	70
Piston coolant nozzles	71
Shoulder half rings	71
Crankshaft axial clearance	71
Shoulder half rings, oversized elements	72
Crankshaft front and back oil seal rings	72
Crankshaft, lubrication lines	73
Crankshaft, check journals and crank	73
Journal and connecting rod pins diameters	73
Main bearings and connecting rod big ends diameters	74
Clearances between the bearings and corresponding pins	74
Hydraulic pump drive	75
Third drive, components	75
7 - TURBOCHARGER	76
Turbo charger	76
Turbocharger components	76
Turbocharger pressure testing	76
Turbocharger wastegate adjustment - regolazione corsa asta comando valvola " wastegate "	77
8 - LUBRIFICATION CIRCUIT	78
Lubrication circuit	78
Internal oil filter and oil sump return pipe	79
Oil pump	79
Oil pump, clearance between rotors	79
Oil pressure regulating valve	80
Oil filter cartridge	80
Oil pressure check	80
9 - COOLANT CIRCUIT	82
Coolant circuit	82
Radiator and compensation, check and seal tank cap	83
Coolant circulation pump, components	83
Thermostatic valve	83
10 - FUEL SYSTEM	84
Fuel feeding / injection circuit	84
Fuel filter detached from the tank (on request)	84
Fuel lift pump	84
Fuel pump drive rod projection	84
Pump/injector unit	85
Pump/injector unit, components	85
Plunger barrel ring nut assembly/disassembly	86
Injection pump assembly/disassembly	86
Plunger injection pump reassembly	86

Pumping element (old-type injection pump)	87
Pumping element	87
Pump/injector unit se.No. 6590.285 Control data	87
Injector, setting (old type).....	89
Setting of injector according to current pump/injector unit.....	89
Injector, nozzle projection.....	89
Injector, spark arrester.....	89
Injection advance control and regulation.....	90
Injection advance for currently used pump/injector unit.....	90
Static injection advance tuning.....	91
Injection advance references on timing belt protector.....	91
Tdc (top dead center) references.....	91
Tester and special coupling for injection advance control (old-type injection pump).....	91
Static injection advance regulation	92
Preliminary steps to pump/injector unit delivery balancing test	92
Closing the oilhole	92
Test head b assembly	92
Instrument connection	93
Injection pumps delivery balancing	93
Electric control panel with automatic engine stop (Upon request).....	94
11 - ELECTRIC SYSTEM.....	94
Alternator, 14v 33a.....	95
Alternator, 14v 33a - performance curve.....	95
Electric starting layout (12v) with alternator 14v 33a.....	96
Alternator 14v 45a - 65a.....	97
Alternator, 14v 45a - performance curve.....	97
Alternator, 14v 65a - performance curve.....	97
Electric starting layout 12v 33a - 45a - 65a.....	98
Flywheel alternator	98
Alternator battery charger curve 12v 30a.....	99
(Two cables at output).....	99
Electric starting layout (12v) with flywheel alternator	100
Voltage regulator connections	100
Starter motor - bosch dw 12v 1,1 kw	101
Starter motor, bosch dw 12v 1,1 kw - performance curve.....	101
Starter motor, bosch 12v 1,6 kw	101
Starter motor, bosch dw 12v 1,6 kw - performance curve.....	102
Pre-heating glow plug.....	102
Pre-heating plug control unit with coolant temperature sensor.....	102
Temperature sensor for control unit.....	103
Oil pressure switch (fig. 215)	103
Pre-heating water temperature thermistor and water temperature indicator thermal contact	103
12 - SETTINGS	104
Speed settings	104
Setting the idle minimum (standard).....	104
Setting the idle maximum (standard).....	104
Pump injection delivery standard setting without dynamometric brake	104
Injection pump flow limiter and engine torque gearing device	105
Pump/injector unit timing with speed governor.....	105
Pump/injector unit delivery setting with braked engine	106
E.G.R. Calibration.....	107
13 - STORAGE	108
Engine storage	108
Protective treatment.....	108
Preparing the engine for operation after protective treatment	109

14 - TORQUE SPECIFICATIONS AND USE OF SEALANT	110
Table of tightening torques for the main components	110
Table of tightening torques for standard screws (coarse thread)	111
Table of tightening torques for standard screws (fine thread)	111
15 - SPECIAL TOOLS	112

The identification plate shown in the figure can be found directly on the engine.

It contains the following information:

- A) Manufacturer's identity
- B) Engine type
- C) Engine serial number
- D) Maximum operating speed
- E) Number of the customer version (form K)
- F) Approval data

Approval data

The approval reference directives EC are on the engine plate (F).

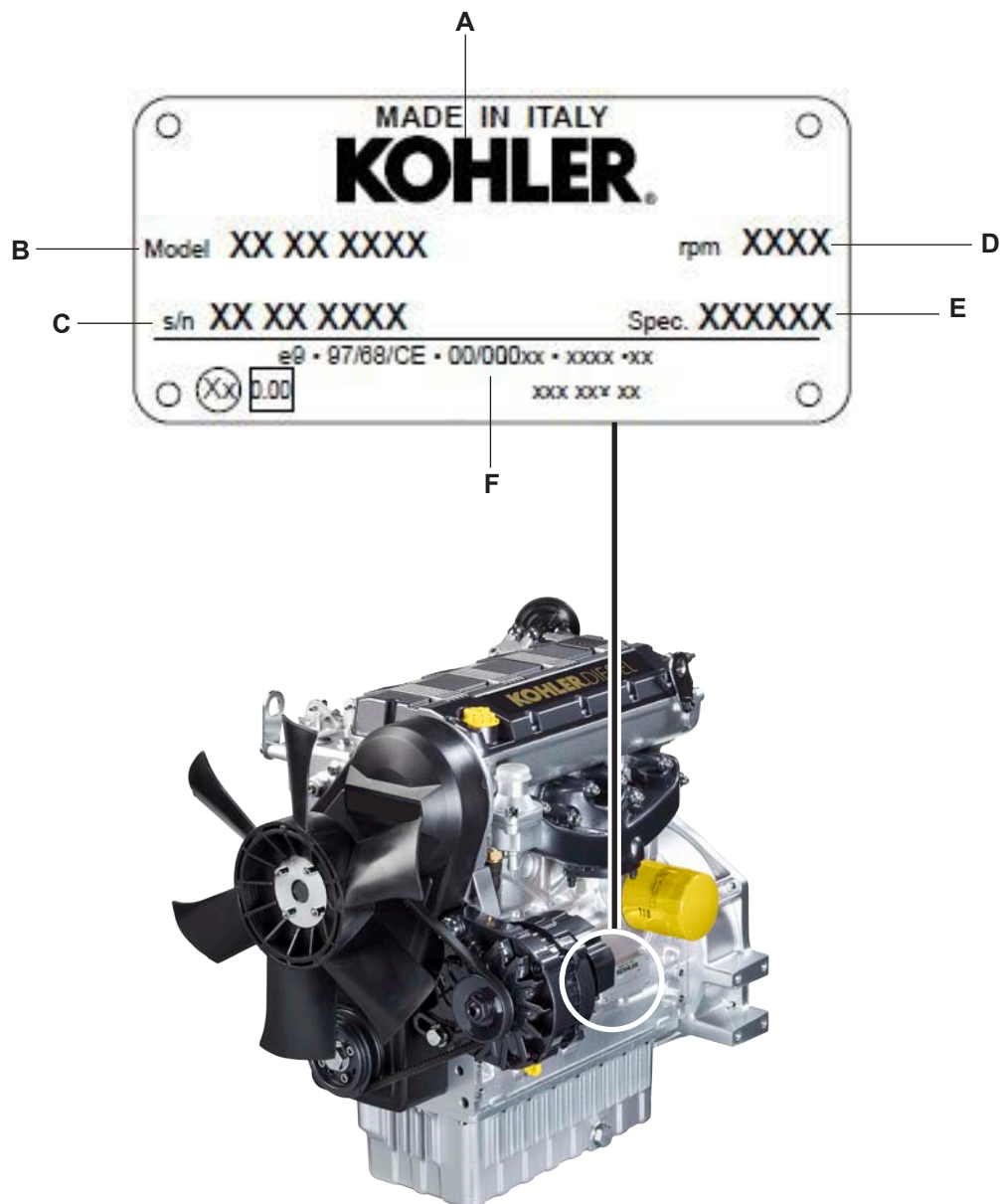

Name plate for EPA rules applied on rocker-arm cap

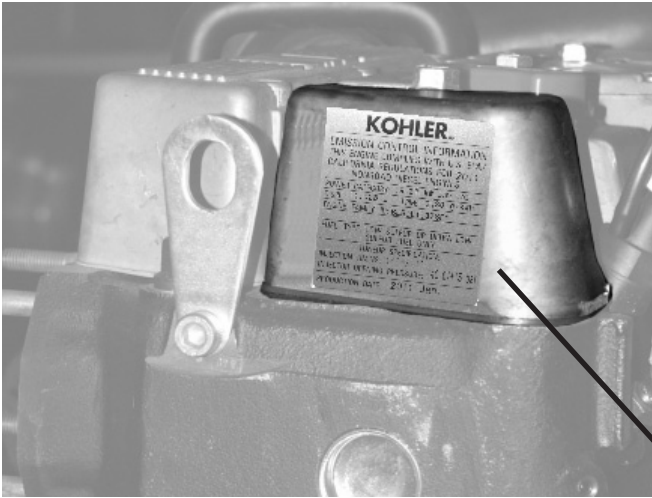

Compilation example

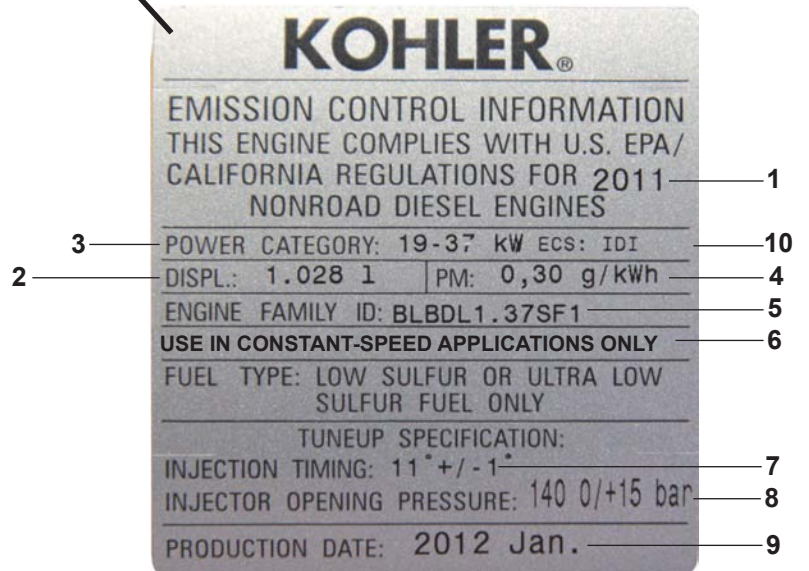

- 1) Model year.
- 2) Engine displacement.
- 3) Power category, kW.
- 4) Particulate emission limit (g/kWh).
- 5) Engine family ID.
- 6) Kind of application i.e.
- 7) Injection timing (BTDC).
- 8) Injector opening pressure (bar).
- 9) Production date (example 2012_Jan).
- 10) Emission Control System = ECS.

To ensure safe operation please read the following statements and understand their meaning. Also refer to your equipment manufacturer's manual for other important safety information. This manual contains safety precautions which are explained below.



Danger – Attention

This indicates situations of grave danger which, if ignored, may seriously threaten the health and safety of individuals.



Caution – Warning

This indicates that it is necessary to take proper precautions to prevent any risk to the health and safety of individuals and avoid financial damage.



Important

This indicates particularly important technical information that should not be ignored.

SAFETY REGULATIONS

DANGER



Accidental Starts can cause severe injury or death.

Disable engine by disconnecting negative (-) battery cable.

Accidental Starts!

Disabling engine. Accidental starting can cause severe injury or death. Before working on the engine or equipment, disable the engine as follows: 1) Disconnect negative (-) battery cable from battery.

DANGER



Rotating Parts can cause severe injury.

Stay away while engine is in operation.

Rotating Parts!

Keep hands, feet, hair, and clothing away from all moving parts to prevent injury. Never operate the engine with covers, shrouds, or guards removed.

DANGER



Carbon Monoxide can cause severe nausea, fainting or death.

Avoid inhaling exhaust fumes, and never run the engine in a closed building or confined area.

Lethal Exhaust Gases!

Engine exhaust gases contain poisonous carbon monoxide. Carbon monoxide is odorless, colorless, and can cause death if inhaled. Avoid inhaling exhaust fumes, and never run the engine in a closed building or confined area.

DANGER



Hot Parts can cause severe burns.

Do not touch engine while operating or just after stopping.

Hot Parts!

Engine components can get extremely hot from operation. To prevent severe burns, do not touch these areas while the engine is running, or immediately after it is turned off. Never operate the engine with heat shields or guards removed.

DANGER



Fuel can cause fires and severe burns.

Do not fill the fuel tank while the engine is hot or running.

Explosive Fuel!

Fuel is flammable and its vapors can ignite. Store fuel only in approved containers, in well ventilated, unoccupied buildings. Do not fill the fuel tank while the engine is hot or running, since spilled fuel could ignite if it comes in contact with hot parts or sparks from ignition. Do not start the engine near spilled fuel. Never use fuel as a cleaning agent.

DANGER



Explosive Gas can cause fires and severe acid burns.

Charge battery only in a well ventilated area. Keep sources of ignition away.

Explosive Gas!

Batteries produce explosive hydrogen gas while being charged. To prevent a fire or explosion, charge batteries only in well ventilated areas. Keep sparks, open flames, and other sources of ignition away from the battery at all times. Keep batteries out of the reach of children. Remove all jewelry when servicing batteries. Before disconnecting the negative (-) ground cable, make sure all switches are OFF. If ON, a spark will occur at the ground cable terminal which could cause an explosion if hydrogen gas or fuel vapors are present.

! DANGER



High Pressure Fluids can puncture skin and cause severe injury or death.
Do not work on fuel system without proper training or safety equipment.

High Pressure Fluid Puncture!

Fuel system is to be serviced only by properly trained personnel wearing protective safety equipment. Fluid puncture injuries are highly toxic and hazardous. If an injury occurs, seek immediate medical attention.

! CAUTION



Electrical Shock can cause injury.
Do not touch wires while engine is running.

Electrical Shock!

Never touch electrical wires or components while the engine is running. They can be sources of electrical shock.

California Proposition 65 WARNING

Engine exhaust from this product contains chemicals known to the State of California to cause cancer, birth defects, or other reproductive harm.

**CALIFORNIA EMISSION CONTROL WARRANTY STATEMENT
YOUR WARRANTY RIGHTS AND OBLIGATIONS**

The California Air Resources Board and Kohler Co. are pleased to explain the **emission control system warranty** on your 2012 engine. In California, new heavy-duty off-road engines must be designed, built and equipped to meet the State's stringent anti-smog standards. Kohler Co. must warrant the emission control system on your engine for the time period listed below provided there has been no abuse, neglect or improper maintenance of your engine.

Your emission control system may include parts such as the fuel-injection system and the air induction system. Also included may be hoses, connectors and other emission related assemblies.

Where a warrantable condition exists, Kohler Co. will repair your heavy-duty off-road engine at no cost to you including diagnosis, parts and labor.

MANUFACTURER'S WARRANTY COVERAGE:

Your off-road, diesel engine emission control system is covered under warranty for a period of five (5) years or 3,000 hours, whichever occurs first, beginning on the date the engine or equipment is delivered to an ultimate purchaser for all constant speed engines with maximum power $19 \leq kW < 37$ and rated speed less than 3,000 rpm, all variable speed engines with maximum power $19 \leq kW < 37$, and all variable or constant speed engines with maximum power greater than 37 kW. Your off-road, diesel engine emission control system on variable or constant-speed engines with maximum power less than 19 kW, and for constant speed engines with maximum power $19 \leq kW < 37$ and rated speed equal to or greater than 3,000 rpm is covered under warranty for a period of two (2) years or 1,500 hours, whichever occurs first. If any emission related part on your engine is defective, the part will be repaired or replaced by Kohler Co.

OWNER'S WARRANTY RESPONSIBILITIES:

As the heavy-duty off-road engine owner, you are responsible for the performance of the **required maintenance listed in your Kohler Co. owner's manual**. Kohler Co. recommends that you retain all receipts covering maintenance on your heavy-duty off-road engine, but Kohler Co. cannot deny warranty solely for the lack of receipts or for your failure to ensure the performance of all recommended scheduled maintenance.

As the heavy-duty off-road engine owner, you should however be aware that Kohler Co. may deny you warranty coverage if your heavy-duty off-road engine or emission control related component has failed due to abuse, neglect, improper maintenance or unapproved modifications.

Your engine is designed to operate on commercial diesel fuel (No. 1 or No. 2 low sulfur or ultra low sulfur diesel fuel) only. Use of any other fuel may result in your engine no longer operating in compliance with California's emissions requirements.

You are responsible for initiating the warranty process. The Air Resources Board suggests that you present your heavy-duty off-road engine to a Kohler Co. dealer as soon as a problem exists. The warranty repairs should be completed by the dealer as expeditiously as possible.

Please review the document titled, "Kohler Co. Federal and California Emission Control Systems Limited Warranty Off-Road Diesel Engines", for complete details of your heavy-duty off-road engine warranty. If you have any questions regarding your warranty rights and responsibilities or the location of the nearest Kohler Co. authorized service location, you should contact Kohler Co. at 1-800-544-2444 or access our website at www.kohlerengines.com.

Explanation of the safety pictograms that can be found on the engine or in the Operation and Maintenance handbook

	Read the Operation and Maintenance handbook before performing any operation on the engine		Use protective gloves before carrying out the operation
	High temperature components - Danger of scalding		Use protective glasses before carrying out the operation
	Presence of rotating parts - Danger of entangling and cutting		Use sound absorbing protections before carrying out the operation
	Presence of explosive fuel - Danger of fire or explosion		Electric shock - Danger of severe scalding or death
			Fluids under high pressure - Danger of fluids penetration
	Presence of steam and pressurized coolant - Danger of scalding		Lethal exhaust gas - Danger of poisoning or death

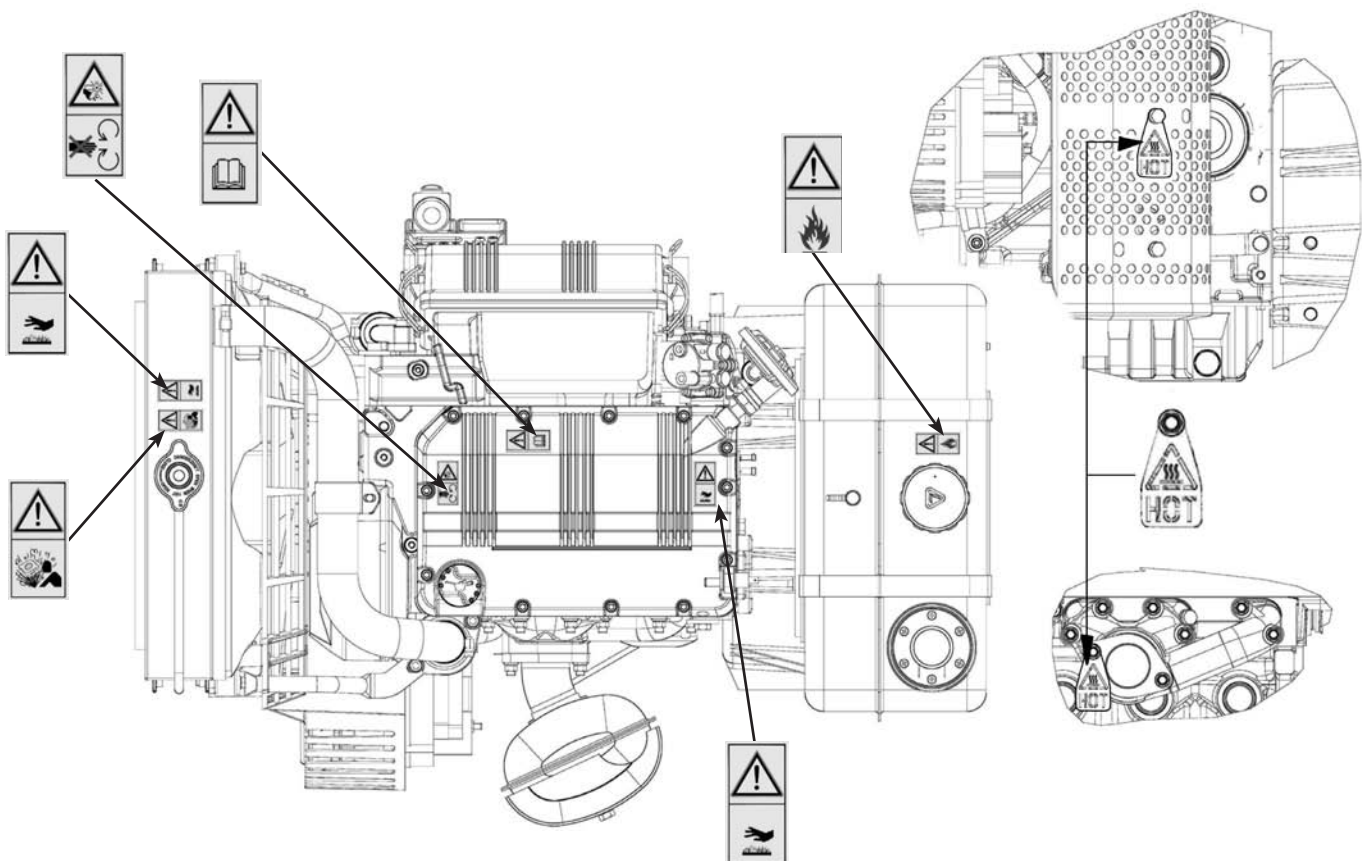
Indications regarding the points on the engine where the safety pictograms are placed

LIMITED 3 YEAR KOHLER® DIESEL ENGINE WARRANTY

Kohler Co. warrants to the original retail consumer that each new KOHLER Diesel engine sold by Kohler Co. will be free from manufacturing defects in materials or workmanship in normal service for a period of three (3) years or 2000 hours whichever occurs first from the date of purchase, provided it is operated and maintained in accordance with Kohler Co.'s instructions and manuals. If no hour meter is installed as original equipment then 8 hours of use per day and 5 days per week will be used to calculate hours used.

Our obligation under this warranty is expressly limited, at our option, to the replacement or repair at Kohler Co., Kohler, Wisconsin 53044, or at a service facility designated by us of such parts as inspection shall disclose to have been defective.

This warranty does not apply to defects caused by unreasonable use, including faulty repairs by others and failure to provide reasonable and necessary maintenance.

The following items are not covered by this warranty:

Engine accessories such as fuel tanks, clutches, transmissions, power-drive assemblies and batteries, unless supplied or installed by Kohler Co. These are subject to the warranties, if any, of their manufacturers.

KOHLER CO. AND/OR THE SELLER SHALL NOT BE LIABLE FOR SPECIAL, INDIRECT, INCIDENTAL OR CONSEQUENTIAL DAMAGES OF ANY KIND, including but not limited to labor costs or transportation charges in connection with the repair or replacement of defective parts.

IMPLIED OR STATUTORY WARRANTIES, INCLUDING WARRANTIES OF MERCHANTABILITY OR FITNESS FOR A PARTICULAR PURPOSE, ARE EXPRESSLY LIMITED TO THE DURATION OF THIS WRITTEN WARRANTY. We make no other express warranty, nor is any one authorized to make any on our behalf.

Some states do not allow limitations on how long an implied warranty lasts, or the exclusion or limitation of incidental or consequential damages, so the above limitation or exclusion may not apply to you.

This warranty gives you specific legal rights, and you may also have other rights, which vary from state to state.

To obtain warranty service

Purchaser must bring the engine to an authorized Kohler service facility. To locate the nearest facility, visit our website, www.kohlerengines.com, and use the locator function, consult your Yellow Pages or telephone 1-800-544-2444.

ENGINE DIVISION, KOHLER CO., KOHLER, WISCONSIN 53044

GENERAL SERVICE MANUAL NOTES

- 1 - Use only genuine Kohler repair parts.
Failure to use genuine Kohler parts could result in sub-standard performance and low longevity.
- 2 - All data presented are in metric format. That is, dimensions are presented in millimeters (mm), torque is presented in Newton-meters (Nm), weight is presented in kilograms (Kg), volume is presented in liters or cubic centimeters (cc) and pressure is presented in barometric units (bar).

GLOSSARY AND TERMINOLOGY

For clarity, here are the definitions of a number of terms used recurrently in the manual.

- **Cylinder number one:** is the piston timing belt side «viewed from the flywheel side of the engine».
- **Rotation direction:** anticlockwise «viewed from the flywheel side of the engine».

SAFETY REGULATIONS

GENERAL NOTES

- **Kohler** engines are built to provide safe and longlasting performances, but in order to obtain these results it is essential that the maintenance requirements described in the manual are observed along with the following safety recommendations.
- The engine has been built to the specifications of a machine manufacturer, and it is his responsibility to ensure that all necessary action is taken to meet the essential and legally prescribed health and safety requirements. Any use of the machine other than that described cannot be considered as complying with its intended purpose as specified by **Kohler**, which therefore declines all responsibility for accidents caused by such operations.
- The following instructions are intended for the user of the machine in order to reduce or eliminate risks, especially those concerning the operation and standard maintenance of the engine.
- The user should read these instructions carefully and get to know the operations described. By not doing so he may place at risk his own health and safety and that of anyone else in the vicinity of the machine.
- The engine may be used or mounted on a machine only by personnel suitably trained in its operation and aware of the dangers involved. This is particularly true for standard and, above all, special maintenance work. For special maintenance contact personnel trained specifically by **Kohler**. This work should be carried out in accordance with existing literature.
- **Kohler** declines all responsibility for accidents or for failure to comply with the requirements of law if changes are made to the engine's functional parameters or to the fuel flow rate adjustments and speed of rotation, if seals are removed, or if parts not described in the operating and maintenance manual are removed and reassembled by unauthorized personnel.



WARNING

- In addition to all other machine specifications, ensure that the engine is in a near horizontal position when starting. If starting manually, ensure that the necessary operations can be performed without any risk of striking against walls or dangerous objects. Rope starting (except for recoil rope starting) is not permitted even in emergencies.
- Check that the machine is stable so that there is no risk of it overturning.
- Get to know the engine speed adjustment and machine stop operations.
- Do not start the machine in closed or poorly ventilated environments. The internal combustion process generates carbon monoxide, an odourless and highly toxic gas, so spending too long a time in an environment where the engine discharges its exhaust products freely can lead to loss of consciousness and even death.
- The engine may not be used in environments containing flammable materials, explosive atmospheres or easily combustible powders, unless adequate and specific precautions have been taken and are clearly stated and certified for the machine.
- To prevent the risk of fire, keep the machine at a distance of at least one metre from buildings or other machines.

- Children and animals must be kept at a sufficient distance from the machine to prevent any danger resulting from its operation.
- Fuel is flammable, so the tank must be filled only when the engine is turned off. Dry carefully any fuel that may have spilled, remove the fuel container and any cloths soaked in fuel or oil, check that any sound-absorbing panels made of porous material are not soaked with fuel or oil, and make sure that the ground on which the machine is located has not absorbed fuel or oil.
- Before starting, remove any tools that have been used for carrying out maintenance work to the engine and/or the machine and check that any guards removed have been replaced. In cold climates it is possible to mix kerosene with the diesel fuel to make the engine easier to start. The liquids must be mixed in the tank by pouring in first the kerosene and then the diesel fuel. Consult **Kohler** technical office for mixture proportions. Petrol may not be used because of the risk of it forming flammable vapours.
- During operation the surface of the engine reaches temperatures that may be dangerous. Avoid in particular all contact with the exhaust system.
- The liquid cooling circuit is under pressure. Do not carry out any checks before the engine has cooled down, and even then open the radiator cap or the expansion tank cautiously. Wear protective clothing and glasses. If there is an electric fan, do not approach the engine while it is still hot as the fan may come on even when the engine is not running. Clean the cooling system with the engine turned off.
- While cleaning the oil bath air filter, check that the oil is disposed of in such a way as not to harm the environment. Any filtering sponges in the oil bath air filter should not be soaked with oil. The cyclone pre-filter cup must not be filled with oil.
- Since the oil must be emptied out while the engine is still hot (approx. 80°C), particular care should be taken in order to avoid burns. In any case make sure that oil does not come into contact with your skin because of the health hazards involved.
- Fuel vapours are highly toxic, so fill up only in the open air or in well ventilated environments.
- During operations which involve access to moving parts of the engine and/or removal of the rotary guards, disconnect and insulate the positive cable of the battery so as to prevent accidental short circuits and activation of the starter motor.
- Check the belt tension only when the engine is turned off.



IMPORTANT

- To start the engine follow the specific instructions provided in the engine and/or machine operating manual. Do not use auxiliary starting devices not originally installed on the machine (e.g. Startpilot systems which utilise ether etc.)
- Before carrying out any work on the engine, turn it off and allow it to cool down. Do not perform any operation while the engine is running.
- Check that the discharged oil, the oil filter and the oil contained in the oil filter are disposed of in such a way as not to harm the environment.
- Close the fuel tank filler cap carefully after each filling operation. Do not fill the tank right up to the top, but leave sufficient space to allow for any expansion of the fuel.
- Do not smoke or use naked flames while filling.

- Take care when removing the oil filter as it may be hot.
- The operations of checking, filling up and replacing the cooling liquid must be carried out with the engine turned off and cold. Take particular care if liquids containing nitrites are mixed with others not containing these compounds as this may give rise to the formation of nitrosamines which are a health hazard. The cooling liquid is polluting, so dispose of in a manner that does not damage the environment.
- In order to move the engine simultaneously use the eyebolts fitted for this purpose by **Kohler**. These lifting points are however not suitable for the entire machine, so in this case use the eyebolts fitted by the manufacturer.

GENERAL SAFETY DURING OPERATING PHASES

- The procedures contained in this manual have been tested and selected by the manufacturer's technical experts, and hence are to be recognised as authorised operating methods.
- Some tools are normal workshop ones, while others are special tools designed by the Manufacturer of the engine.
- All tools must be in good working condition so that engine components are not damaged and that operations are carried out properly and safely.
- It is important to wear the personal safety devices prescribed by work safety laws and also by the standards of this manual.
- Holes must be lined up methodically and with the aid of suitable equipment. Do not use your fingers to carry out this operation to avoid the risk of amputation.
- Some phases may require the assistance of more than one operator. If so, it is important to inform and train them regarding the type of activity they will be performing in order to prevent risks to the health and safety of all persons involved.
- Do not use flammable liquids (petrol, diesel, etc.) to degrease or wash components. Use special products.
- Use the oils and greases recommended by the manufacturer. Do not mix different brands or combine oils with different characteristics.
- Discontinue use of the engine if any irregularities arise, particularly in the case of unusual vibrations.
- Do not tamper with any devices to alter the level of performance guaranteed by the manufacturer.

SAFETY AND ENVIRONMENTAL IMPACT

Every organisation has a duty to implement procedures to identify, assess and monitor the influence of its own activities (products, services, etc.) on the environment.

Procedures for identifying the extent of the impact on the environment must consider the following factors:

- Liquid waste;
- Waste management;
- Soil contamination;
- Atmospheric emissions;
- Use of raw materials and natural resources;
- Regulations and directives regarding environmental impact.

In order to minimise the impact on the environment, the manufacturer now provides a number of indications to be followed by all persons handling the engine, for any reason, during its expected lifetime.

- All packaging components must be disposed of in accordance with the laws of the country in which disposal is taking place.
- Keep the fuel and engine control systems and the exhaust pipes in efficient working order to limit environmental and noise pollution.
- When discontinuing use of the engine, select all components according to their chemical characteristics and dispose of them separately.

TROUBLE SHOOTING

THE ENGINE MUST BE STOPPED IMMEDIATELY WHEN:

- 1) - The engine rpms suddenly increase and decrease;
- 2) - A sudden and unusual noise is heard;
- 3) - The colour of the exhaust fumes suddenly darkens;
- 4) - The oil pressure indicator light turns on while running.

TABLE OF LIKELY ANOMALIES AND THEIR SYMPTOMS

The following table contains the possible causes of some failures which may occur during operation. Always perform these simple checks before removing or replacing any part.

POSSIBLE CAUSE		TROUBLE												
		Engine does not start	Engine starts but stops	No acceleration	Non-uniform speed	Black smoke	White smoke	Oil pressure too low	Oil level increase	Excessive oil consumption	Oil and fuel dripping from the exhaust	Engine overheats	Inadequate performance	High noise level
FUEL CIRCUIT	Clogged fuel pipes													
	Clogged fuel filter													
	Air or water in the fuel circuit													
	Tank cap breather blocked													
	Faulty fuel pump													
	Lack of fuel													
ELECTRIC SYSTEM	Glow plug fuse burned													
	Faulty glow plug control relay													
	Flat battery													
	Unclear or mistaken cable connection													
	Faulty starter switch													
	Faulty starting motor													
	Faulty glow plugs													
MAINTENANCE	Clogged air filter													
	Prolonged operation at idle													
	Incomplete run-in													
	Overloaded engine													
SETTINGS REPAIRS	Excessive valve clearances													
	Absence of valve clearances													
	Incorrect speed governor leverages													
	Speed governor spring broken or disengaged													
	Idle low													
	Worn out or stuck rings													
	Worn out cylinders													
	Worn out valve guides													
	Bad valve seal													
	Bearing shells of bearing cap - piston rod - rocker worn out													
	E.G.R. valve blocked open													
	Governor leverages not running													
	Cylinder head gasket damaged													
	Faulty timing system													
	Supplementary starter spring broken or disengaged													

POSSIBLE CAUSE		TROUBLE												
		Engine does not start	Engine starts but stops	No acceleration	Non-uniform speed	Black smoke	White smoke	Oil pressure too low	Oil level increase	Excessive oil consumption	Oil and fuel dripping from the exhaust	Engine overheats	Inadequate performance	High noise level
LUBRICATION CIRCUIT	High oil level													
	Low oil level													
	Dirty or blocked pressure regulation valve													
	Worn oil pump													
	Air to the oil suction hose													
	Faulty manometer or pressure switch													
	Oil in sump suction hose blocked													
	Oil in sump drainage pipe blocked													
	Faulty spray nozzles (Turbo engines only)													
INJECTION	Damaged injector													
	Damaged injection pump valve													
	Incorrectly calibrated injector													
	Worn or damaged pumping element													
	Incorrect injection pump delivery setting (delivery equalisation)													
	Hardened pump/injector control rod													
	Cracked or broken pre-combustion chamber													
	Incorrect adjustment of the injection systems (delivery equalisation advance)													
COOLING CIRCUIT	Insufficient refrigerant fluid													
	Defective fan, radiator, or radiator cap													
	Defective thermostatic valve													
	Loss of refrigerant fluid from the radiator, hoses, engine crankshaft or water pump.													
	Inside of radiator or coolant lines obstructed.													
	Defective or worn water pump													
	Alternator fan drive belt loose or torn													
	Heat exchange surface of the radiator clogged													

TECHNICAL SPECIFICATIONS

ENGINE TYPE		KDW 702	KDW 1003	KDW 1404
Cylinders	N°	2	3	4
Bore	mm	75	75	75
Stroke	mm	77.6	77.6	77.6
Displacements	Cm ³	686	1028	1372
Compression rate		22,8:1	22,8:1	22,8:1
Rpm		3600	3600	3600
Maximum power	N 80/1269/CEE-ISO 1585	12.5(17.0)	19.5(26.5)	26.0(35.2)
	NB ISO 3046 - IFN	11.7(16)	18(24.5)	24.5(33.3)
	NA ISO 3046 - ICXN	10.7(14.5)	16.5(22.4)	22.4(30.5)
Maximum torque *	Nm	40.5	67.0	84.0
	RPM	@ 2000	@2000	@ 2000
Maximum Torque Available @ N° 3 PTO 3600 Rpm	Nm	37@1800	37@1800	37@1800
Specific fuel consumption**	g/KWh	320	300	325
Oil consumption ***	Kg/h	0,009	0,013	0,019
Dry weight of engine	Kg	66	87	98
Combustion air volume at 3600 Rpm	l./1'	1240	1850	2470
Cooling air volume at 3600 Rpm	m ³ /mm	43	63	88
Axial load allowed on crankshaft (both directions)	Kg	300	300	300
Max tilt	Instant operation (up to 1 min)	α	35°	35°
	Intermittent operation (up to 30 min)	α	25°	25°
	Permanent operation	α	****	****

- * At NB power
- ** Referred to NB power
- *** Measured at NA power
- **** Depends on application
- At 3600 Rpm
- Measured at NB power

KDW 702



KDW 1003

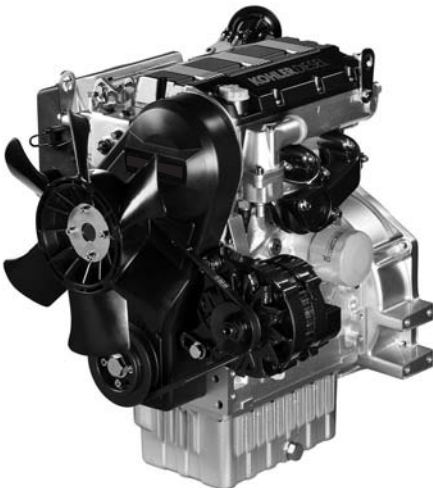

KDW 1404



PERFORMANCE DIAGRAMS

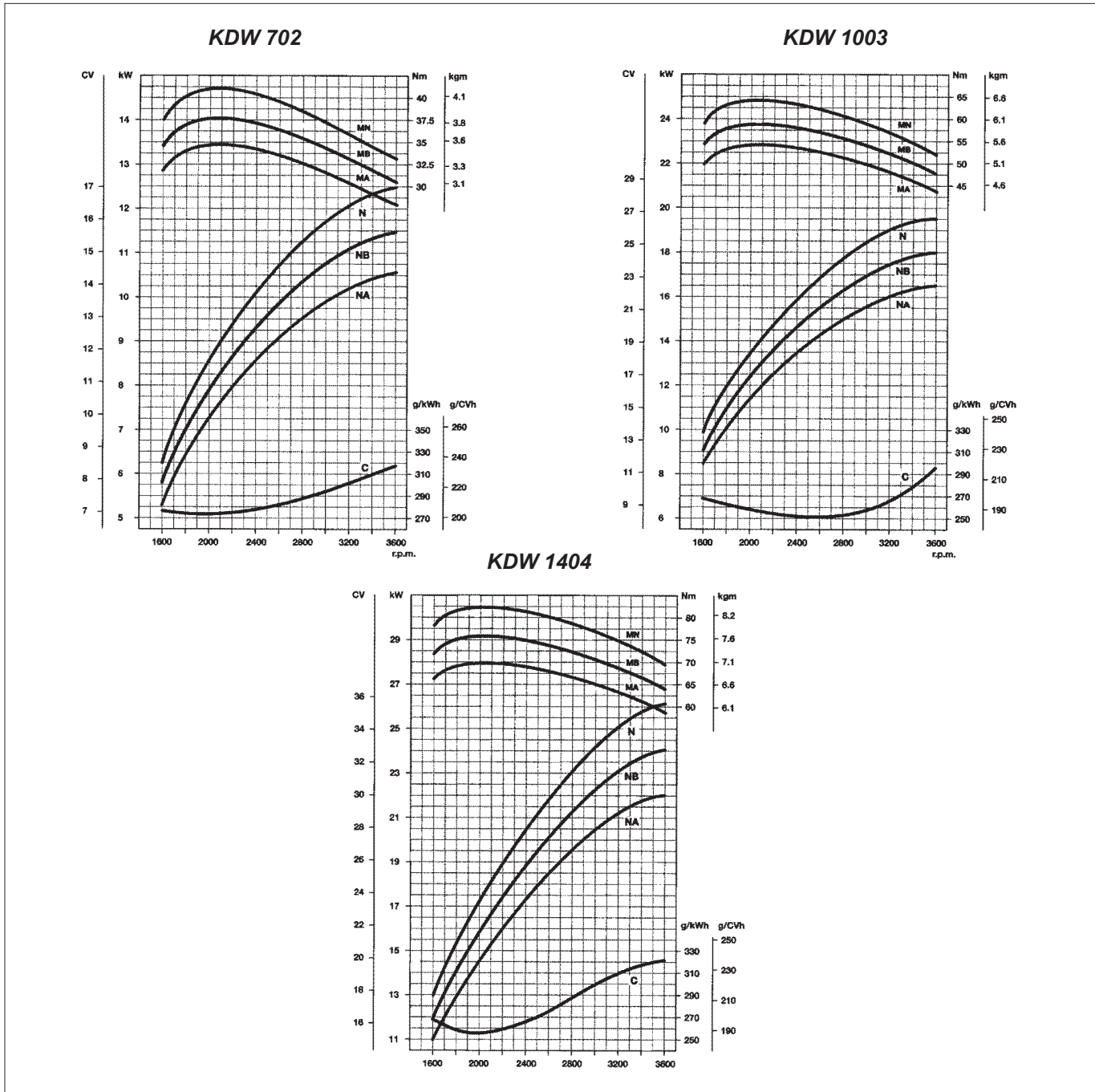

N (DIN 70020) Automotive rating, intermittent operation with variable speed and variable load.

NB (DIN 6270) Rating with no overload capability, continuous light duty operation with constant speed and variable load.

NA (DIN 6270) Continuous rating with overload capability, continuous heavy duty with constant speed and constant load.

C (NB) : Specific fuel consumption at NB power

Mt : Torque at N.

a : Range of application for continuous operation. In case of application outside this range please contact KOHLER.

The above power values refer to an engine fitted with air cleaner and standard muffler, after testing and at the environmental conditions of 20°C and 1 bar. Max. power tolerance is 5%. Power decreases by approximately 1% every 100 m di altitude and by 2% every 5°C above 25°C.

Note: Consult KOHLER for power, torque curves and specific consumptions at rates differing from those given above.



Important

Non-approval by KOHLER for any modifications releases the company from any damages incurred by the engine.

OVERALL DIMENSION

KDW 702

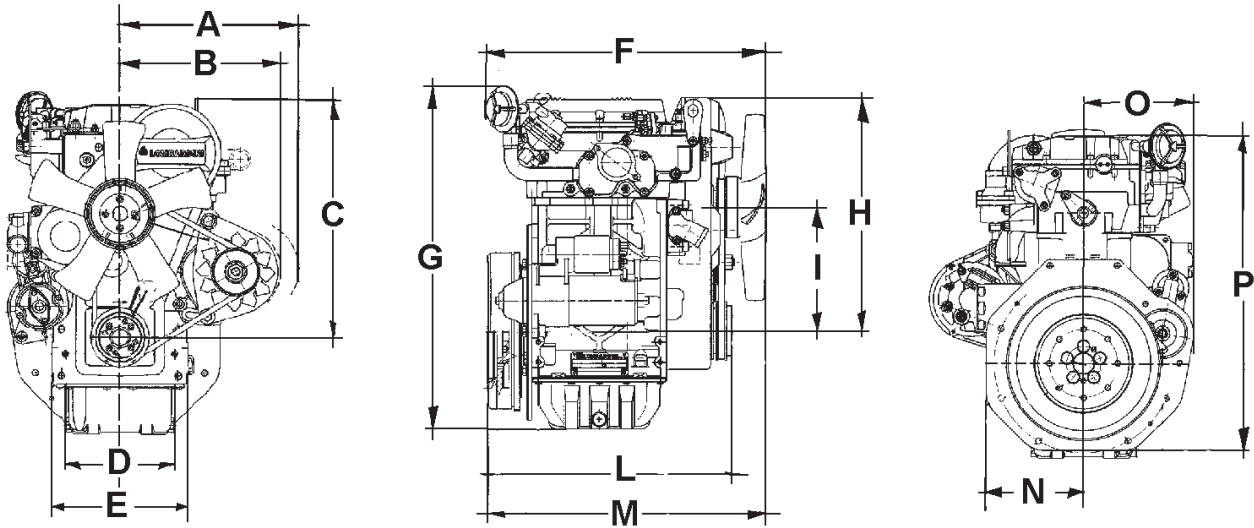

DIMENSIONS mm (in.) - DIMENSIONI mm - MESURES mm - EINBAUMAßE mm - DIMENSIONE mm - DIMENÇÕES mm													
A	269.2 (10.6)	C	359 (14.13)	E	204 (8.03)	G	515.5 (20.3)	I	186 (7.32)	M	418 (16.46)	O	169.5 (6.67)
B	242.5 (9.55)	D	165 (6.5)	F	421 (16.57)	H	351.5 (13.84)	L	367 (14.45)	N	150 (5.90)	P	484.5 (19.07)

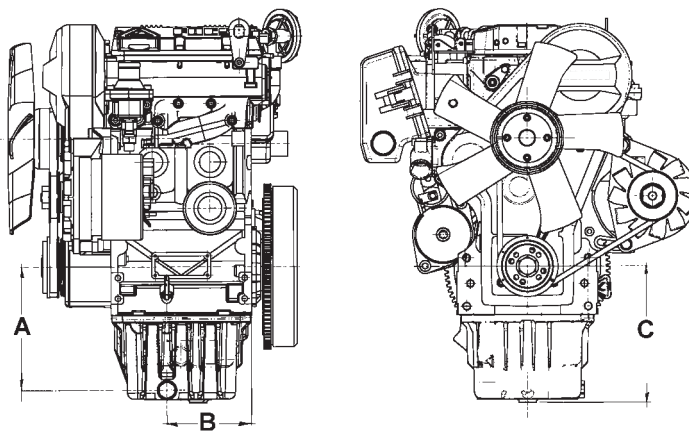

DIMENSIONS mm (in.) - DIMENSIONI mm - MESURES mm - EINBAUMAßE mm - DIMENSIONE mm - DIMENÇÕES mm													
A	178.85 (7.04)	B	122.25 (4.81)	C	197.85 (7.78)								

LDW 1003

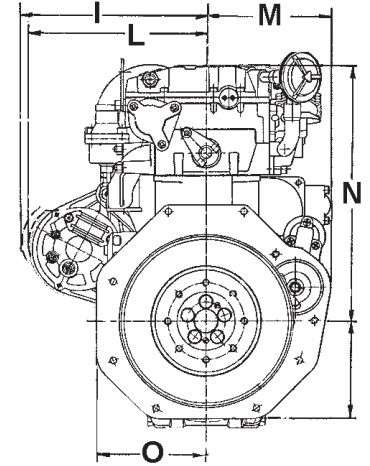
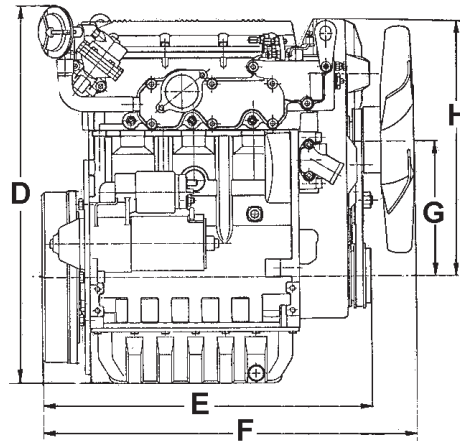
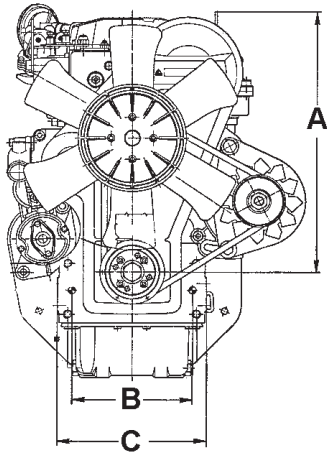

COPPA OLIO STANDARD IN LAMIERA - CARTER D'HUILE EN TÔLE STANDARD - SHEET METAL STANDARD OIL SUMP - STANDARD BLECHÖLWANNE - CÂRTER DE ACEITE STANDARD EN PLANCHA - CÂRTER DE ÓLEO STANDARD EM CHAPA

DIMENSIONS mm (in.) - DIMENSIONI mm - MESURES mm - EINBAUMAßE mm - DIMENSIONE mm - DIMENÇÕES mm													
A	359 (14.13)	C	204 (8.03)	E	450 (17.72)	G	186 (7.32)	I	269.2 (10.6)	M	169.5 (6.67)	O	150 (5.90)
B	165 (6.5)	D	515.5 (20.3)	F	510 (20.08)	H	351.5 (13.84)	L	242.5 (9.54)	N	484.5 (19.07)		

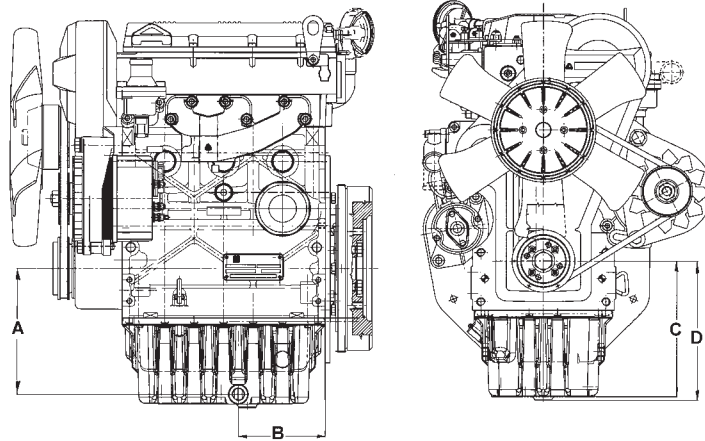

COPPA OLIO MAGGIORATA IN ALLUMINIO - CARTER D'HUILE SURDIMENSIONNÉ EN ALUMINIUM - OVERSIZE ALUMINIUM OIL SUMP - VERGRÖßERTER ALUMINIUMÖLWANNE - CÂRTER DE ACEITE SOBREDIMENSIONADO EN ALUMINIO - CÂRTER DE ÓLEO AUMENTADO - EM ALUMINIO

DIMENSIONS mm (in.) - DIMENSIONI mm - MESURES mm - EINBAUMAßE mm - DIMENSIONE mm - DIMENÇÕES mm													
A	178.85 (7.04)	B	122.25 (4.81)	C	192.5 (7.58)	D	197.85 (7.79)						

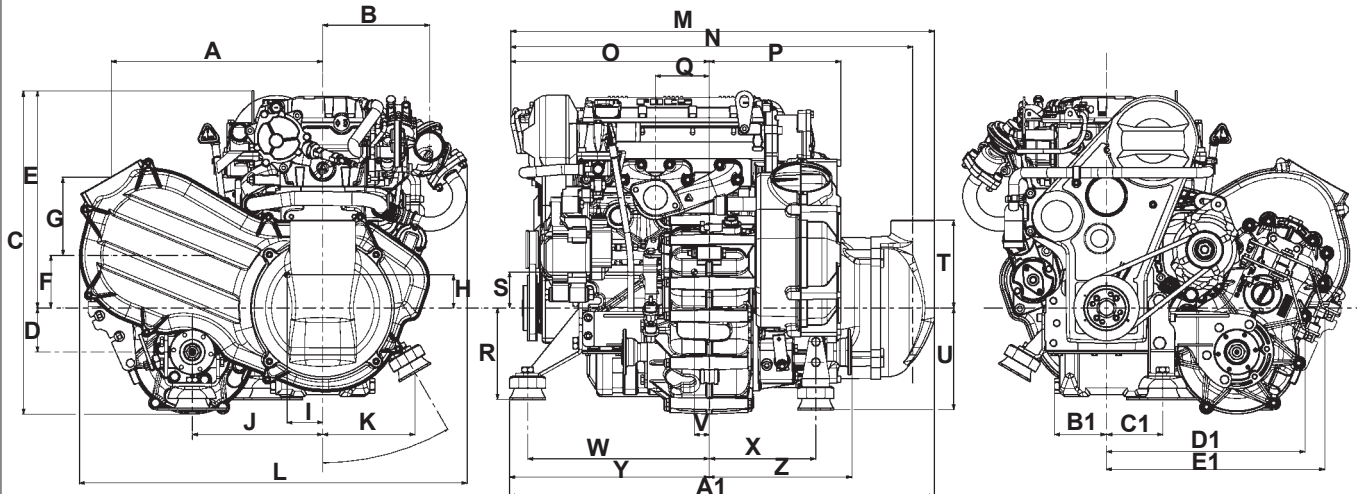
KDW 1003 with EGR circuit, Gear-box and CVT (Continuous Variable Transmission)

DIMENSIONI mm - MESURES mm - DIMENSION mm - EINBAUMAßE mm - DIMENSIONE mm - DIMENÇÕES (mm)													
A	350,2	F	87	K	152,9	P	218	U	168,4	Z	236,4	E1	361,8
B	177	G	129,3	L	641,8	Q	89	V	25	A1	703,5		
C	534,5	H	54,8	M	701,7	R	151,5	W	300,5	B1	86		
D	72,9	I	58,8	N	685,7	S	59,6	X	176,5	C1	93		
E	359,1	J	215,9	O	328,7	T	145	Y	330,5	D1	329		

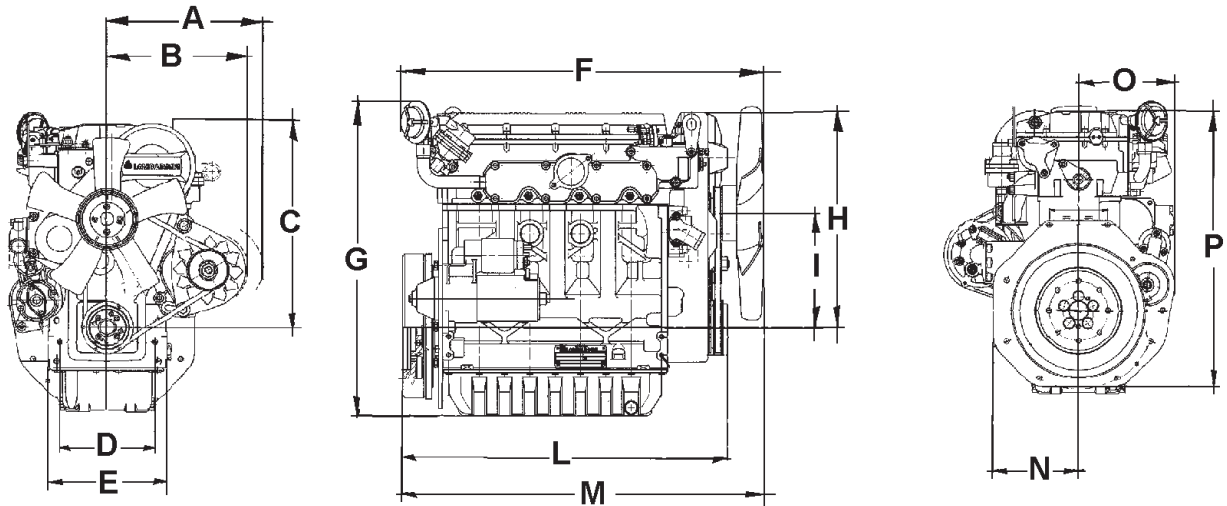
KDW 1404

COPPA OLIO STANDARD IN LAMIERA - CARTER D'HUILE EN TÔLE STANDARD - SHEET METAL STANDARD OIL SUMP - STANDARD BLECHÖLWANNE - CÂRTER DE ACEITE STANDARD EN PLANCHA - CÂRTER DE ÓLEO STANDARD EM CHAPA

DIMENSIONS mm (in.) - DIMENSIONI mm - MESURES mm - EINBAUMAßE mm - DIMENSIONE mm - DIMENÇÕES (mm)													
A	269.2 (10.60)	C	359 (14.13)	E	204 (8.03)	G	515.5 (20.30)	I	186 (7.32)	M	593 (23.35)	O	169.5 (6.67)
B	242.5 (9.55)	D	165 (6.50)	F	596 (23.46)	H	351.5 (13.84)	L	533 (20.98)	N	150 (5.90)	P	484.5 (19.07)

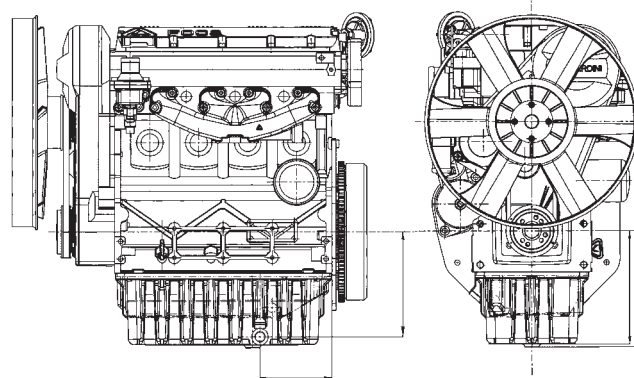

COPPA OLIO MAGGIORATA IN ALLUMINIO - CARTER D'HUILE SURDIMENSIONNÉ EN ALUMINIUM - OVERSIZE ALUMINIUM OIL SUMP - VERGRÖßERTER ALUMINIUMÖLWANNE - CÂRTER DE ACEITE SOBREDIMENSIONADO EN ALUMINIO - CÂRTER DE ÓLEO AUMENTADO - EM ALUMINIO

DIMENSIONS mm (in.) - DIMENSIONI mm - MESURES mm - EINBAUMAßE mm - DIMENSIONE mm - DIMENÇÕES (mm)													
A	122.25 (4.81)	B	178.5 (7.03)	C	192.5 (7.58)	D	197.85 (7.79)						

ROUTINE ENGINE MAINTENANCE

Important

Failure to carry out the operations described in the table may lead to technical damage to the machine and/or system.

ORDINARY MAINTENANCE

AFTER THE FIRST
50 WORKING HOURS

Engine oil replacement.

Oil filter replacement.

EXTRAORDINARY MAINTENANCE

OPERATION DESCRIPTION		FREQUENCY x HOURS							
			10	250	300	500	1000	5000	10000
CHECK	ENGINE OIL LEVEL								
	COOLANT LEVEL								
	AIR FILTER (DRY-TYPE)	(***)							
	RADIATOR EXCHANGE SURFACE	(**)							
	VALVE CLEARANCE ADJUSTMENT	(**)							
	FAN / ALTERNATOR	(*)							
	BELT STRETCH								
	COOLING LIQUID HOSES	(*)							
	SETTING AND INJECTORS CLEANING	(**)							
	FUEL PIPES								
	RUBBER INTAKE HOSE (AIR FILTER AND INTAKE MANIFOLD)								
	INTERIOR RADIATOR CLEANING								
	ALTERNATOR AND STARTING MOTOR								
	REPLACEMENT	ENGINE OIL	(*)						
OIL FILTER		(*)							
FUEL FILTER		(*)							
ALTERNATOR BELT		(**)							
COOLANT		(**)							
FILTER ELEMENT PANEL AIR FILTER		(***)							
FUEL PIPES		(**)							
COOLING LIQUID HOSES		(**)							
RUBBER INTAKE HOSE (AIR FILTER AND INTAKE MANIFOLD)		(**)							
TIMING BELT		(°)							
DRY AIR CLEANER EXTERNAL CARTRIDGE		(***)							
DRY AIR CLEANER INTERNAL CARTRIDGE	(***)								
OVERHAUL	PARTIAL								
	TOTAL								

250 STANDARD OIL SUMP

300 ENHANCED OIL SUMP

(*) - In case of low use: every year.

(**) - In case of low use: every 2 years.

(***) - The period of time that must elapse before cleaning or replacing the filter element depends on the environment in which the engine operates. The air filter must be cleaned and replaced more frequently in very dusty conditions.

(°) - Once removed, the timing belt should be replaced even if its scheduled motion period is not over.

PRESCRIBED LUBRICANT

AGIP SINT 2000 5W40	specifications	API SJ/CF ACEA A3-96 B3-96 MIL - L-46152 D/E
--------------------------------	----------------	---

In the countries where AGIP products are not available, use oil API CF/SH for Diesel engines or oil corresponding to the military specification MIL-L-2104 C/46152 D.

ENGINES OIL CAPACITY		KDW 702	KDW 1003	KDW 1404	
OIL VOLUME AT MAX LEVEL (OIL FILTER INCLUDED)	Sheet STD oil sump.	Litres	1,6	2,4	3,2
	ENHANCED aluminium oil sump.		2,5	3,8	5,2
OIL VOLUME AT MAX LEVEL (WITHOUT OIL FILTER)	Sheet STD oil sump.	Litres	1,5	2,3	3,0
	ENHANCED aluminium oil sump.		2,4	3,7	5,1

* With dynamic balancer



Important

If you are using oil of a quality lower than the prescribed one then you will have to replace it every 125 hours for the standard sump and every 150 hours for the enhanced sump.



Danger – Attention

- The engine may be damaged if operated with insufficient lube oil. It is also dangerous to supply too much lube oil to the engine because a sudden increase in engine rpm could be caused by its combustion.
- Use proper lube oil preserve your engine. Good quality or poor quality of the lubricating oil has an affect on engine performance and life.
- If inferior oil is used, or if your engine oil is not changed regularly, the risk of piston seizure, piston ring sticking, and accelerated wear of the cylinder liner, bearing and other moving components increases significantly.
- Always use oil with the right viscosity for the ambient temperature in which your engine is being operated.



Danger – Attention

- The used engine oil can cause skin-cancer if kept frequently in contact for prolonged periods.
- If contact with oil cannot be avoided, wash carefully your hands with water and soap as soon as possible.
- Do not disperse the oil in the ambient, as it has a high pollution power.

COOLANT



Danger – Attention

- The fluid coolant circuit is pressurized. Inspections must only be made when the engine has cooled and even in this case, the radiator or expansion chamber plug must be unscrewed with the utmost caution.
- If an electric fan is installed, do not approach a hot engine since the fan itself could start up even when the engine is at a standstill.
- Coolant fluid is polluting, it must therefore be disposed of in the correct way. Do not litter.

The anti-freeze protection liquid (AGIP ANTIFREEZE SPEZIAL) must be used mixed with water, preferably decalcified. The freezing point of the cooling mixture depends on the product concentration in water, it is therefore recommended to use a 50% diluted mixture which guarantees a certain degree of optimal protection. As well as lowering the freezing point, the permanent liquid also raises the boiling point.

Prescribed coolant.

**50 % AGIP ANTIFREEZE
SPEZIAL**

50 % Water

Coolant refueling

ENGINE TYPE	KDW 702	KDW 1003	KDW 1404
CAPACITY (Litres) Without radiator	0,90	1,30	1,75

For information concerning the capacity of KOHLER radiators, please contact KOHLER directly.
The total volume for refilling the cooling liquid varies according to the type of engine and radiator.

FUEL RECOMMENDATIONS

Purchase diesel fuel in small quantities and store in clean, approved containers. Clean fuel prevents the diesel fuel injectors and pumps from clogging. Do not overfill the fuel tank.
Leave room for the fuel to expand. Immediately clean up any spillage during refueling.

Never store diesel fuel in galvanized containers; diesel fuel and the galvanized coating react chemically to each other, producing flaking that quickly clogs filters or causes fuel pump or injector failure.

High sulfur content in fuel may cause engine wear. In those countries where diesel has a high sulfur content, it is advisable to lubricate the engine with a high alkaline oil or alternatively to replace the lubricating oil recommended by the manufacturer more frequently. The regions in which diesel normally has a low sulfur content are Europe, North America, and Australia.

PRESCRIBED LUBRICANT	
Fuel with low sulphur content	API CF4 - CG4
Fuel with high sulphur content	API CF

FUEL TYPE

For best results, use only clean, fresh, commercial-grade diesel fuel. Diesel fuels that satisfy the following specifications are suitable for use in this engine: ASTM D-975 - 1D or 2D, EN590, or equivalent.

FUELS FOR LOW TEMPERATURES

It is possible to run the engine at temperatures below 0°C using special winter fuels. These fuels reduce the formation of paraffin in diesel at low temperatures. If paraffin forms in the diesel, the fuel filter becomes blocked interrupting the flow of fuel.

Fuel can be:

- Summer up to 0°C
- Winter up to -10°C
- Alpine up to -20°C
- Arctic up to -30°C

BIODIESEL FUEL

Fuels containing less than 20% methyl ester or B20, are suitable for use in this engine. Biodiesel fuels meeting the specification of BQ-9000 or equivalent are recommended. DO NOT use vegetable oil as a biofuel for this engine.
Any failures resulting from the use of fuels other than recommended will not be warranted.

AVIATION FUEL

Aviation fuels suitable for use in this engine include JP5, JP4, JP8 and, JET-A (if 5 percent oil is added).

EMISSION CONTROL INFORMATION

**LOW SULFUR FUEL OR
ULTRA LOW SULFUR FUEL ONLY**

EPA /CARB emission label must be attached near the fuel inlet.

**Important**

- Before removing the engine from the vehicle on which it is installed, disconnect the power supply, detach the fuel and coolant supply, and all connections including the mechanical ones.
- Attach the engine to a suitable lifting device (lifting beam).
- Hook the lifting device in the engine lifting points, as shown in the figure.
- Before lifting, make sure the weight is correctly balanced by checking its barycentre.
- Close all engine openings accurately (exhaust, intake, etc.), then wash the outside and dry with a jet of compressed air.

**Important**

The bracket of the lifting points have been designed to lift the engine only. They are not intended nor approved to lift additional weights. Do not use different methods to lift the engine than those described herein. In case different methods are used, no warranty shall be granted for any consequential damage.



Use protective gloves when handling the engine

RECOMMENDATIONS FOR DISASSEMBLING AND ASSEMBLING



Important

To locate specific topics, the reader should refer to the index.

- Besides disassembly and reassembly operations this chapter also includes checking and setting specifications, dimensions, repair and operating instructions.
- Always use original KOHLER spare parts for proper repair operations.
- The operator must wash, clean and dry components and assemblies before installing them.
- The operator must make sure that the contact surfaces are intact, lubricate the coupling parts and protect those that are prone to oxidation.
- Before any intervention, the operator should lay out all equipment and tools in such a way as to enable him to carry out operations correctly and safely.
- For safety and convenience, you are advised to place the engine on a special rotating stand for engine overhauls.
- Before proceeding with operations, make sure that appropriate safety conditions are in place, in order to safeguard the operator and any persons involved.
- In order to fix assemblies and/or components securely, the operator must tighten the fastening parts in a criss-cross or alternating pattern.
- Assemblies and/or components with a specific tightening torque must initially be fastened at a level lower than the assigned value, and then subsequently tightened to the final torque.

RECOMMENDATIONS FOR OVERHAULS AND TUNING



Important

To locate specific topics, the reader should refer to the index.

- Before any intervention, the operator should lay out all equipment and tools in such a way as to enable him to carry out operations correctly and safely.
- The operator must comply with the specific measures described in order to avoid errors that might cause damage to the engine.
- Before carrying out any operation, clean the assemblies and/or components thoroughly and eliminate any deposits or residual material.
- Wash the components with special detergent and do not use steam or hot water.
- Do not use flammable products (petrol, diesel, etc.) to degrease or wash components. Use special products.
- Dry all washed surfaces and components thoroughly with a jet of air or special cloths before reassembling them.
- Apply a layer of lubricant over all surfaces to protect them against oxidation.
- Check all components for intactness, wear and tear, seizure, cracks and/or faults to be sure that the engine is in good working condition.
- Some mechanical parts must be replaced *en bloc*, together with their coupled parts (e.g. valve guide/valve etc.) as specified in the spare parts catalogue.



Danger - Attention

During repair operations, when using compressed air, wear eye protection.

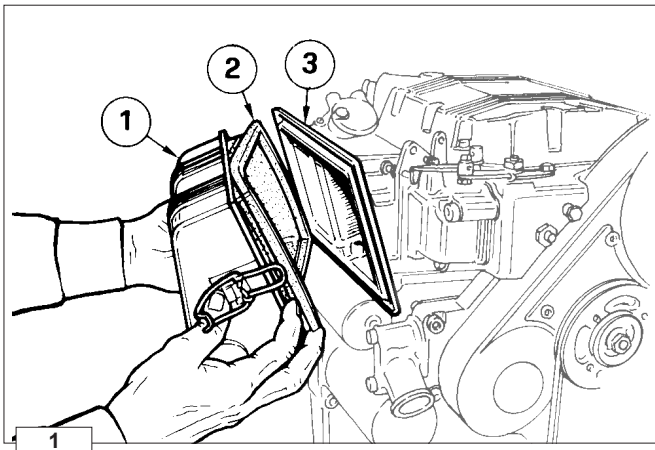

Dry type air filter

! Danger - Attention
 Never clean the filtering element with highly flammable solvents. Danger of explosion!

i Important
 Blow compressed air crossways over the external part and inside the cartridge at a pressure no greater than 5 atm or if necessary knock the front of the cartridge repeatedly against a flat surface.

- Components:**
- 1 Cover
 - 2 Filter element
 - 3 Support

Air filter specifications:

- Filtration level = 13÷14 µm.
- Filtration area = 4470 cm² for 702, 1003
- Filtration area = 7150 cm² for 1404

➡ See page 32 for periodic maintenance details.

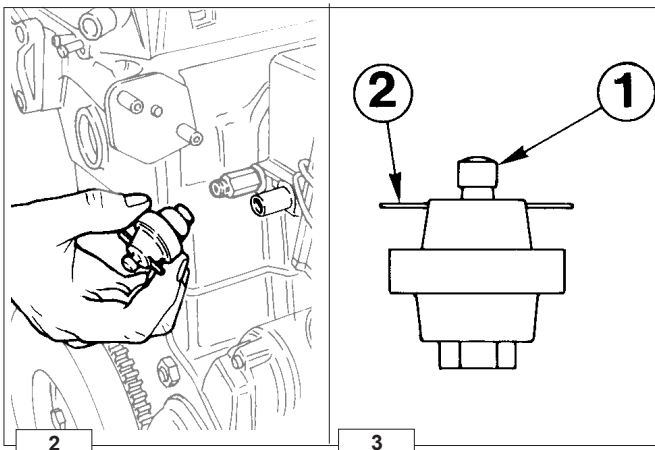

Air restriction switch

- Components:**
- 1 Reset button
 - 2 .25" Tab connection

Note: The indicator is calibrated at 600÷650 mm of water column for KDW 702, 1003, 1404.

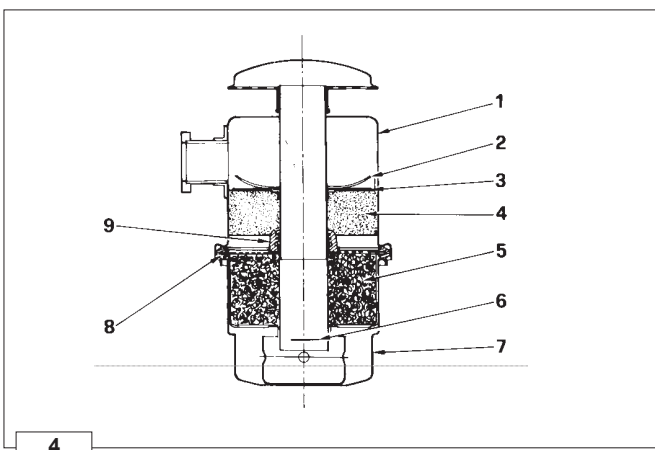

Oil bath air cleaner (on request)

i Important
 Check the sealing rings regularly.
 Replace the sealing rings if hardening or damage is noted

- 1 Upper Housing
- 2 Diaphragm Seat
- 3 Diaphragm
- 4 Polyurethane upper element
- 5 Metal wool lower element
- 6 Oil level reference mark
- 7 Reservoir bowl
- 8 Outer seal ring
- 9 Inner seal ring

Note: Carefully clean the reservoir bowl and both elements with clean diesel fuel. Blow the lower element dry with compressed air. Dry the upper element by squeezing out excess diesel fuel, then drying with suitable cloths. Fill the reservoir with clean engine oil to the reference mark.

➡ See page 32 for periodic maintenance and replacement details.

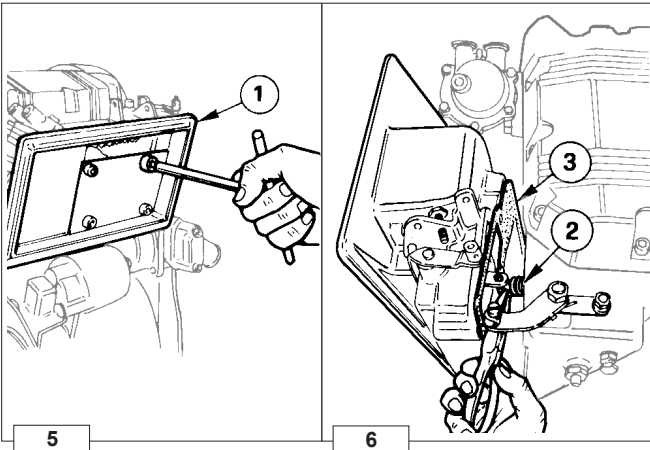

Air filter support

The support for air filter 1 incorporates the intake manifold and the accelerator control box.
 Remove all bolts that secure the air filter support 1 to the cylinder head. Carefully pull the air filter support from the cylinder head. Using suitable pliers, release the governor spring 2 from the air filter support assembly.
 Replace the gasket 3.

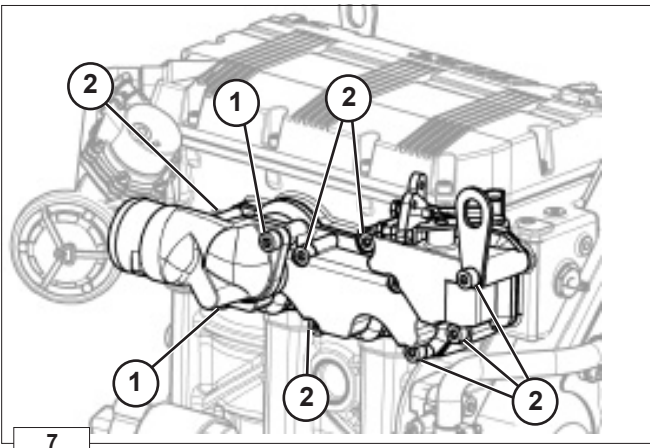

Intake manifold – Remote air filter

Unscrew the the fastening screws 1 that fix the intake duct to the intake manifold unit.
 Unscrew the two fastening screws 2 of the intake manifold from the engine crankcase.
 Lift the intake manifold and disengage the hook of the min/max cylinder from the same manifold (fig. 212).

E.G.R. Circuit

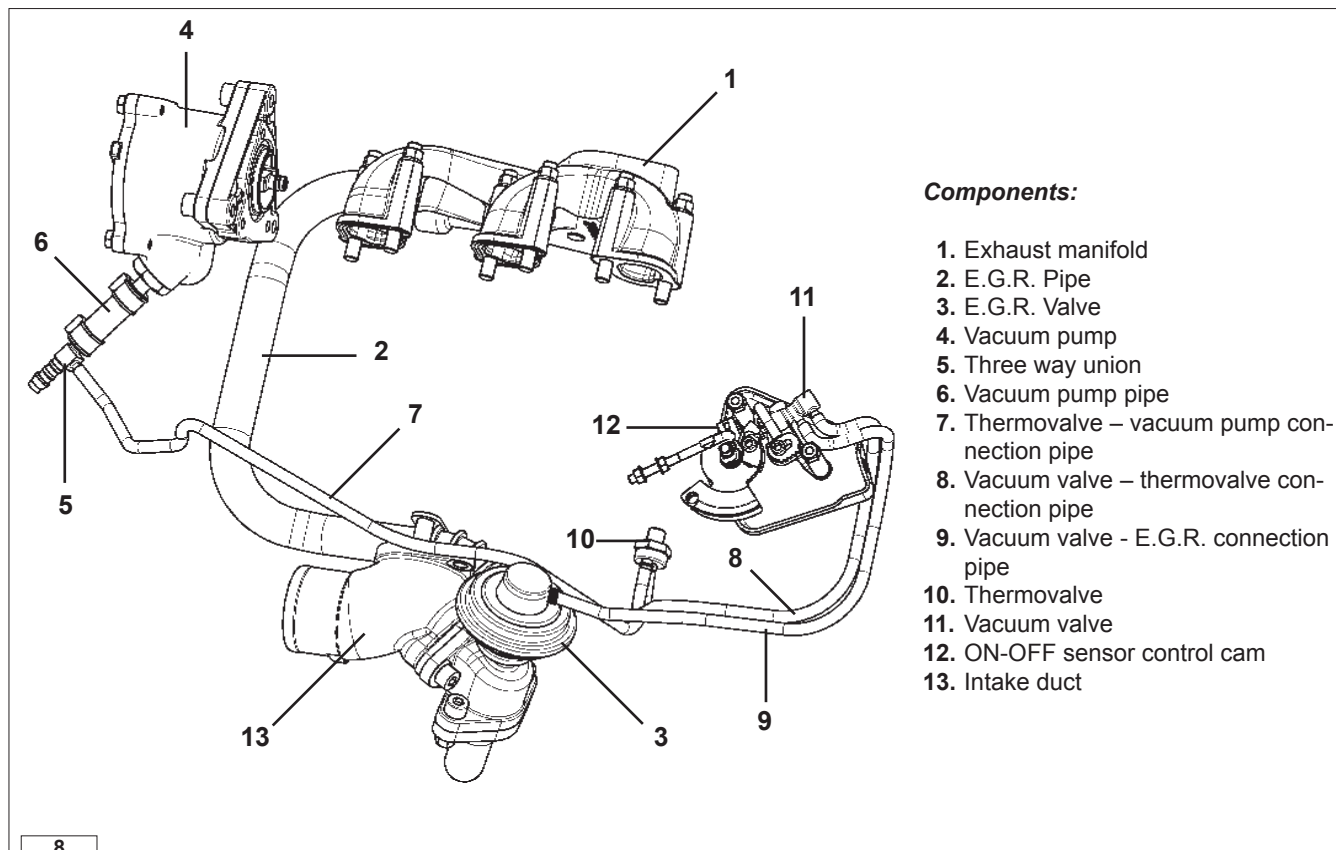
**Components:**

1. Exhaust manifold
2. E.G.R. Pipe
3. E.G.R. Valve
4. Vacuum pump
5. Three way union
6. Vacuum pump pipe
7. Thermovalve – vacuum pump connection pipe
8. Vacuum valve – thermovalve connection pipe
9. Vacuum valve - E.G.R. connection pipe
10. Thermovalve
11. Vacuum valve
12. ON-OFF sensor control cam
13. Intake duct

Operation

The main function of the E.G.R. (Exhaust Gas Recirculation) system is the reduction in emission of NOx (nitrogen oxides), gases harmful to people and the environment, via lowering the combustion temperature.

The system takes a certain quantity of exhaust gas from the exhaust manifold **1** via the E.G.R. pipe **2** to the E.G.R. valve **3**.

This valve is opened by the vacuum (created in pipes **6**, **7**, **8** and **9** by vacuum pump **4**) only when:

- a) thermovalve **10** placed in contact with the engine refrigerant fluid reaches a temperature of 40 °C;
- b) the on-off sensor control cam **12** opens the vacuum valve **11** at a determined accelerator position.

Once the E.G.R. valve is opened, the exhaust gas enters the intake manifold **13** via the intake flange.

The same logic controls the closure of the E.G.R. valve.

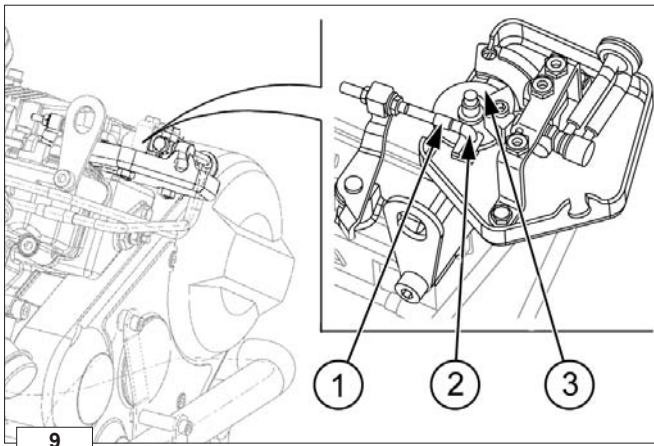

E.G.R. Circuit

Disassembly:

- Disengage the control rod catch 1 with a screwdriver from the accelerator control rod 2.
- Disconnect the accelerator control rod 2 from the accelerator control lever 3 .

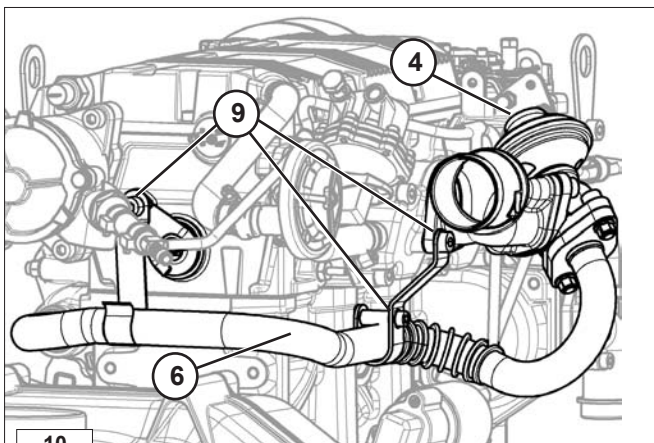

- Disconnect the thermo valve – vacuum pump connection pipes (7, fig. 8) and vacuum valve – thermo valve connection pipe (8, fig. 8) from the thermo valve.
- Unscrew the two fastening screws 5 that fix the E.G.R. pipe 6 to the E.G.R. valve 4 (figures 10, 11 and 12).

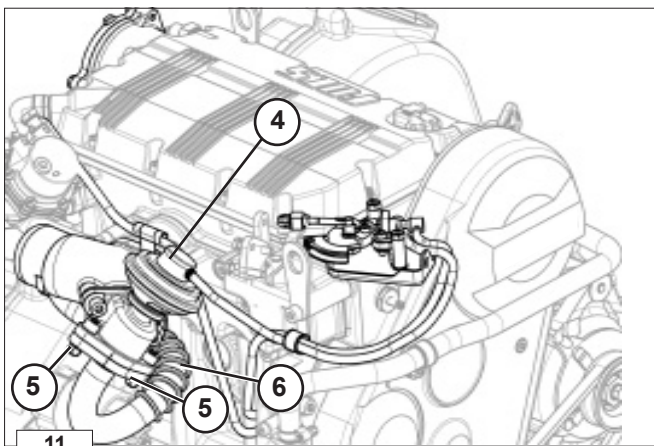

- Remove the intake manifold. See "Intake manifold – Remote air filter" on page 39 (Figure 7).
- Unscrew the fastening screw of the E.G.R. pipe support bracket (9, fig. 10) from the engine crankcase and disengage the E.G.R. pipe from the exhaust manifold.

Reassembly:

When reassembling pay attention to the repositioning of the gaskets and to the precise connection of the pipes (6, 7, 8, 9, fig. 8).

These pipes should be carefully fitted on the appropriate connections.

- Tighten the screws to specified torque, see "Table of tightening torques for the main components" on page 110-111.

- For the calibration of the E.G.R. system see "E.G.R. calibration" on page 107.

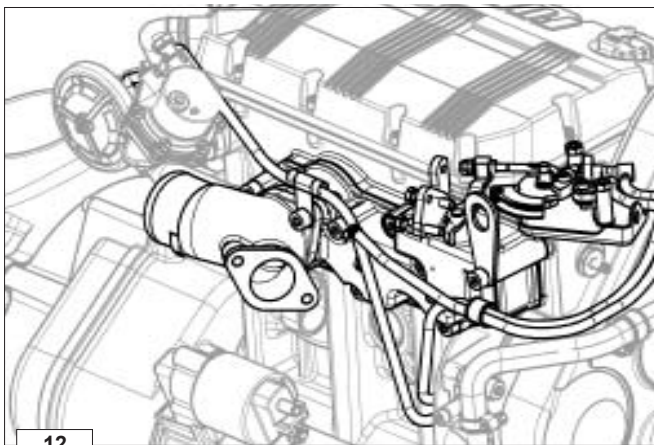

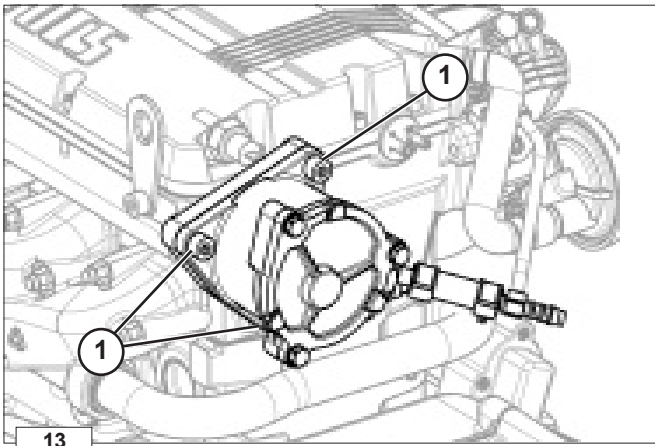

Vacuum pump and vacuum pump flange

Unscrew the three fastening screws 1 that fix the vacuum pump to the flange and remove the vacuum pump.
Unscrew the fastening screws that fix the flange to the engine crankcase and remove it.

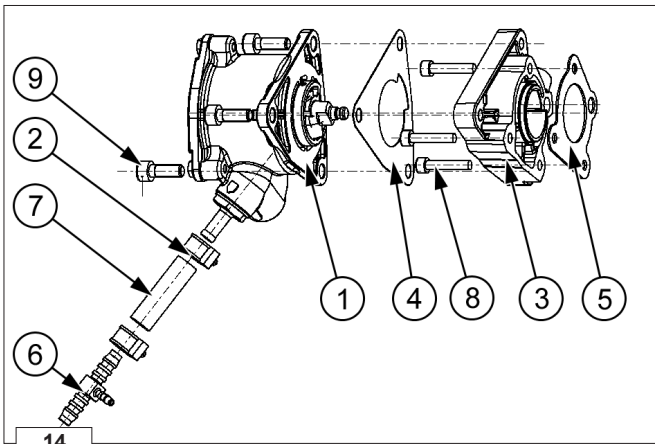

Components:

- 1. Vacuum pump
- 2. Clic clamp 86-50
- 3. Vacuum pump flange
- 4. Vacuum pump gasket
- 5. Vacuum pump flange gasket
- 6. Three-way union for vacuum pump
- 7. Vacuum pump pipe
- 8. Screw
- 9. Screw

○ When reassembling, tighten the screws 8 that fix the flange to the cylinder head to the specified torque of 10 Nm, and the screws 9 that fix the vacuum pump to the flange at the specified torque of 15 Nm.

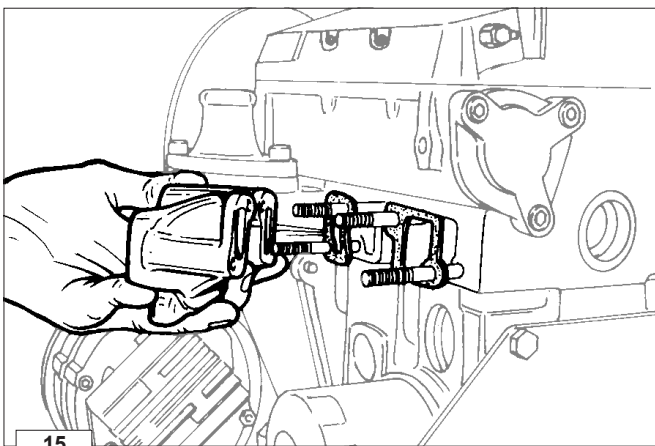

Exhaust manifold

! Danger - Attention

Let the exhaust manifold cool before dismounting to avoid scalds and burns.

When you dismount the exhaust manifold check that the inside is properly clean and free from cracks or breaks.
Replace gaskets every time you remove the manifold.

○ Tighten nuts at 25 Nm.

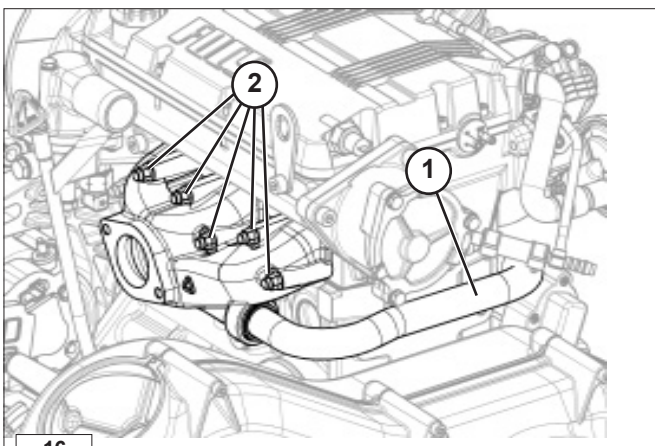

Exhaust manifold - engines with EGR

Remove the E.G.R. pipe 1.
Unscrew the locking nuts 2 and remove the exhaust manifold and the seal.

! Caution - Warning

**When reassembling the exhaust manifold, check that the inside is properly clean and free from cracks or breaks.
Replace the gasket each time the manifold is reassembled.**

○ Tighten the nuts at the prescribed torque of 25 Nm.

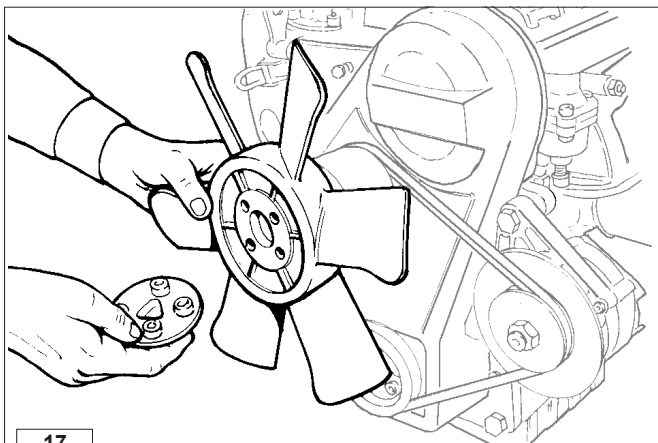

17

Cooling fan

! Danger - Attention

Carry out the cooling fan disassembly, only after isolating the positive battery cable to prevent accidental short-circuiting and, consequently, the activation of the starter motor.

Carefully clean and check all blades. Replace the fan even if there is only a single damaged blade.

➤ See pages 20-21 for cooling air flow volume.

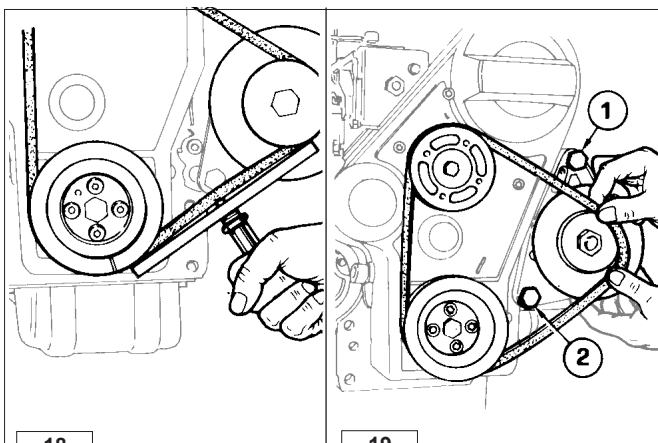

18

19

Alternator/Cooling fan belt drive

! Danger - Attention

Check the belt tension only with the engine off.

Tension adjustment.

Loosen screws 1 and 2.

Adjust the belt tension so that a 100N force at the midpoint of the belt center (as shown) results in a 10-15mm deflection.

➤ See page 32 for periodic maintenance details.

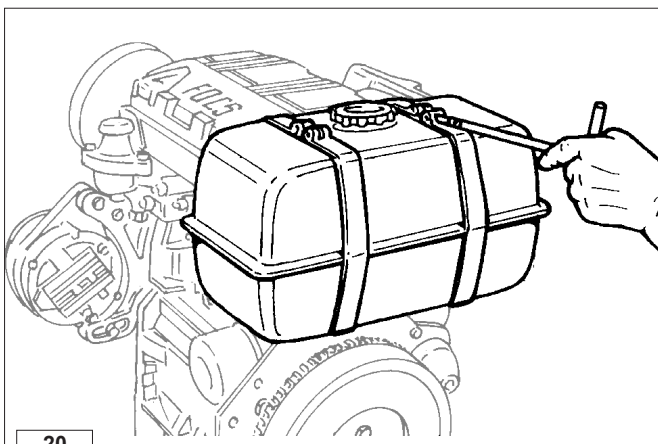

20

Fuel tank (optional)

! Danger - Attention

To avoid explosions or fire outbreaks, do not smoke or use naked flames during the operations.

Fuel vapours are highly toxic. Only carry out the operations outdoors or in a well ventilated place. Keep your face well away from the plug to prevent harmful vapours from being inhaled.

Dispose of fuel in the correct way and do not litter as it is highly polluting.

After disconnecting the fuel pipes unscrew the anchoring brackets' screws and remove the fuel tank.

Completely empty the tank and check that no impurities are found inside.

Check that cap breather hole is not clogged.

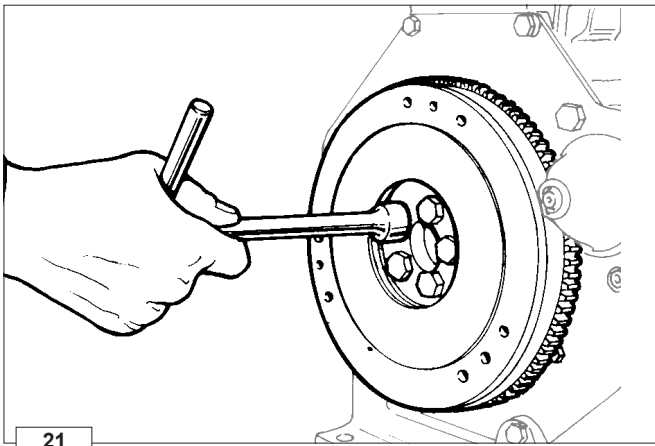

21

Flywheel

! Danger - Attention

During dismantling be particularly careful not to let the flywheel fall, as this can be very dangerous for the operator. Use protective goggles while removing the starter ring gear.

Unscrew the screws that fasten it to the crankshaft. In order to replace the ring gear, it is necessary to disassemble the flywheel.

Cut the ring gear in several places using a chisel and remove it. Heat the new ring gear uniformly and keep it at a temperature of 300°C for 15÷20 minutes.

Insert the ring gear into its seat and place it carefully on the rim of the flywheel.

Leave the ring gear to cool gently before reassembling the flywheel.

- When refitting tighten the screws at 80 Nm.

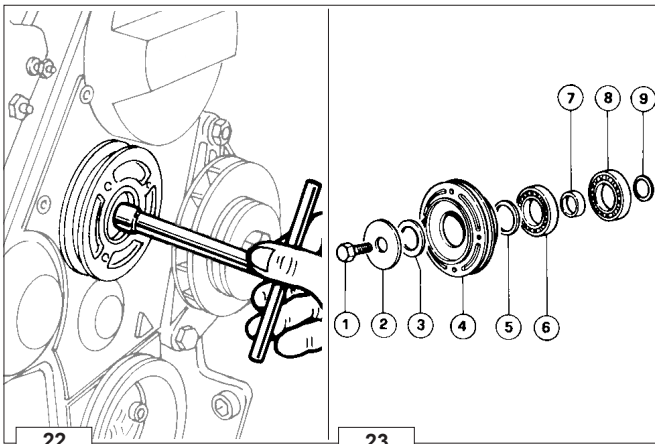

22

23

Return pulley

Remove the center bolt 1 and slide the pulley from the engine.

Components:

- | | |
|-------------|-------------|
| 1 Bolt | 6 Bearing |
| 2 Washer | 7 Spacer |
| 3 Spacer | 8 Bearing |
| 4 Pulley | 9 Snap Ring |
| 5 Snap Ring | |

- On remounting thoroughly clean out the threads of screw 1 and tighten at 25 Nm.

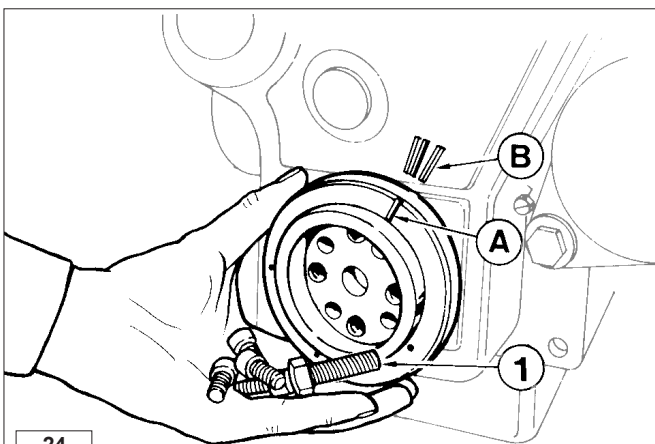

24

Driving pulley

i Important

To loosen or screw in screw 1 at the set torque you must always stop the crankshaft and not other parts of the engine.

Locking the crankshaft: remove the engine starter and installing the fixture tool 1460-051.

Remove the pulley, after having unscrewed central screw 1 and proceed with the four lateral screws.

The central bolt 1 is left-handed.

- When reassembling, apply some Moly-slip antiseizure compound on the screw 1 thread and tighten at 360 Nm.

Note: When pulley reference mark A aligns with the timing cover reference mark B, the flywheel side piston is at (TDC).

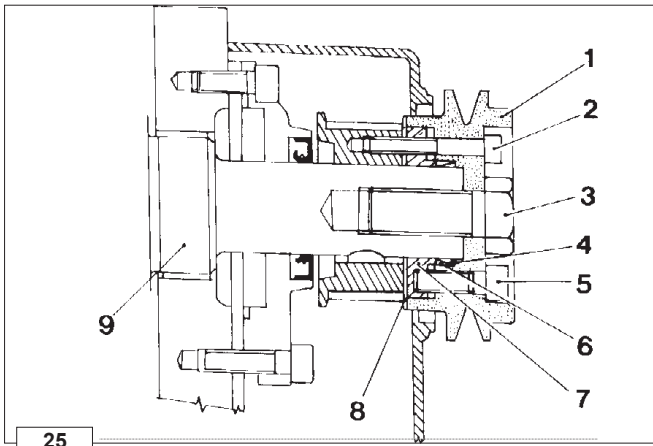

25

Ringfeder-type rings on KDW 1404

It is possible to draw $\frac{3}{4}$ of the power from the second drive of KDW 1404 engines.
If you want to draw the entire power it is necessary to mount the Ringfeder rings on the crankshaft handle.

Components:

- | | |
|---------------------------|---------------------------|
| 1 Puleggia appropriata | 6 Ringfeder external ring |
| 2 Screw M6 | 7 Spacer flange |
| 3 Screw M16 x 1,5 | 8 Shoulder plate |
| 4 Ringfeder internal ring | 9 Crankshaft |
| 5 Screw M8 | |

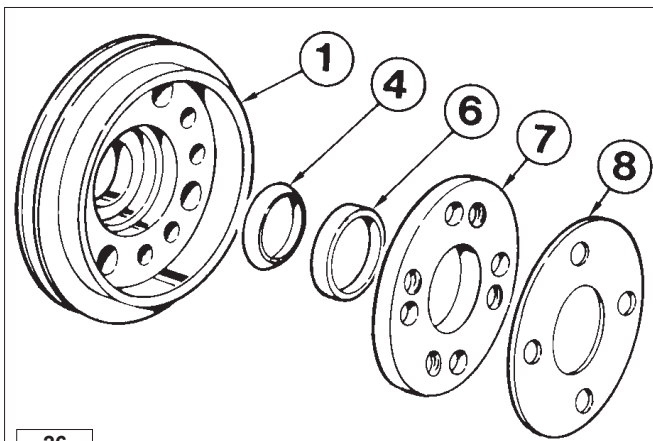

26

Ringfeder-type rings on KDW 1404 - Assembly

Refer to figures 25 and 26.
Clean and oil the parts involved in the mounting with engine oil.
Insert into pulley 1, the internal ring 4 and the external ring 6, then flange 7 by tightening it temporarily with its screws.
Before assembling the pulley 1 in the crankshaft taper, insert shoulder ring 8.

Lock the crankshaft using tool 7107-1460-051.

- Tighten the screws 2 at a torque of 10 Nm.
- Tighten the screws 3 at a torque of 360 Nm.
- Tighten the screws 5 uniformly in criss-cross pattern in three distinct phases:

- 1° phase = 15 Nm
- 2° phase = 35 Nm
- 3° phase = torque check.

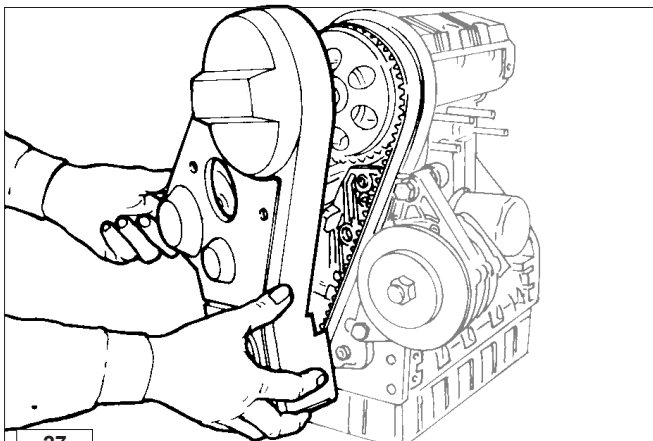

27

Timing belt cover

Loosen the five screws and remove the cover.

- When refitting tighten the screws at a torque of 10 Nm.

Check the peripheral rubber sealing gasket and the two dust-protection rings of the two pulleys, if mounted.

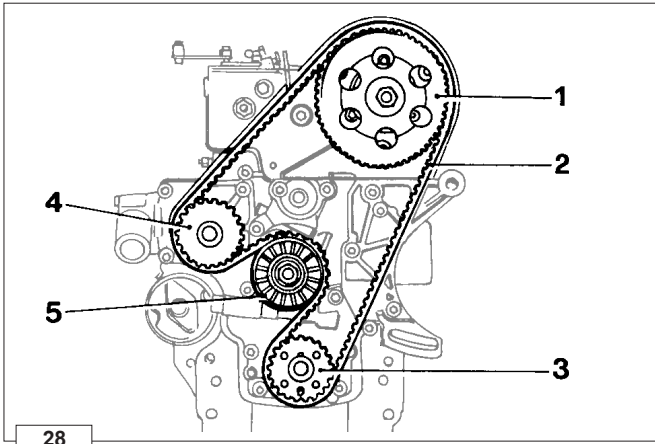

Timing belt / Timing pulley arrangement

Components:

- 1 Camshaft pulley
- 2 Timing belt
- 3 Crankshaft pulley
- 4 Coolant pump pulley
- 5 Belt tensioner pulley

28

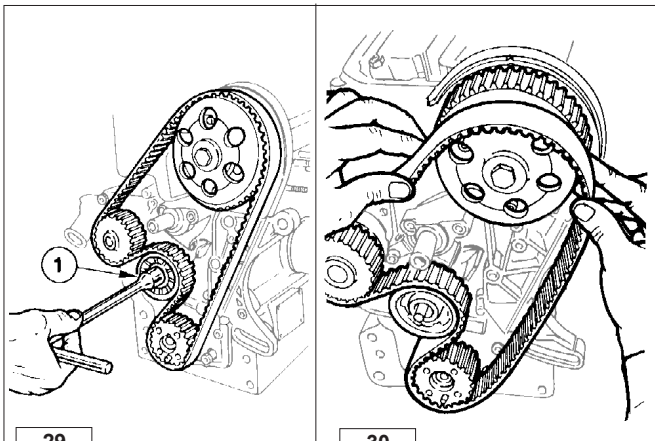

Timing belt removal

⚠ Caution – Warning

When you remove the distributor belt replace it even if its prescribed operation time has not expired yet.

⚠ Danger – Attention

Always check that the positive pole of the battery is insulated.

Remove the belt tensioner 1.
Remove the timing belt off the timing pulley.

➡ For assembly see fig. 36.

29

30

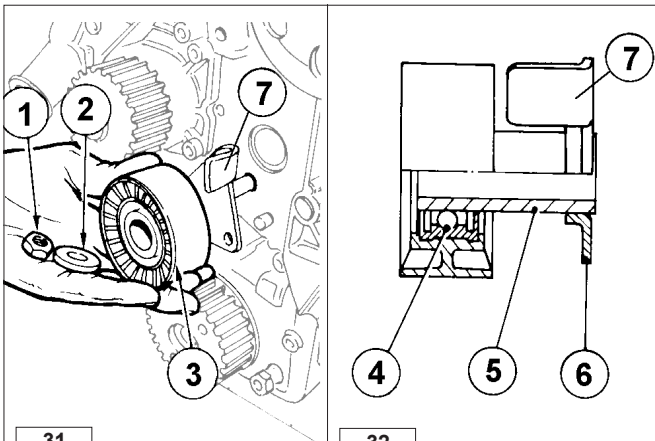

Tightening pulley

Components:

- 1 Nut
- 2 Washer
- 3 Pulley
- 4 Bearing
- 5 Shaft/Support
- 6 Mounting plate
- 7 Tensioning lever

31

32

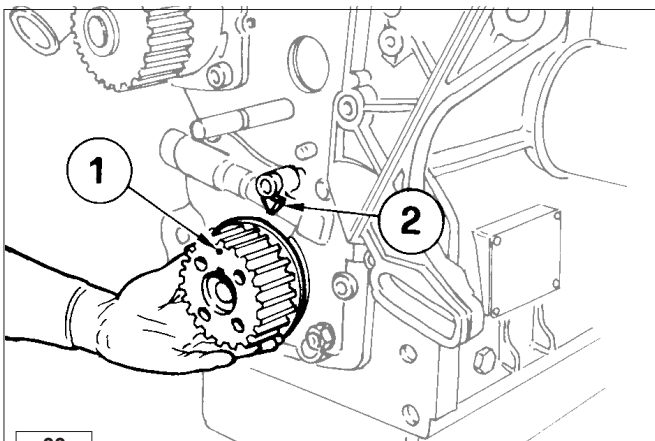

Crankshaft timing pulley

⚠ Important

When reassembling, make sure that the key remains inserted in its place.

Note: Reference mark 1 on the crankshaft timing pulley and reference mark 2 on the oil pump housing are timing marks. When aligned, No. 1 piston (flywheel side) is at TDC.

33

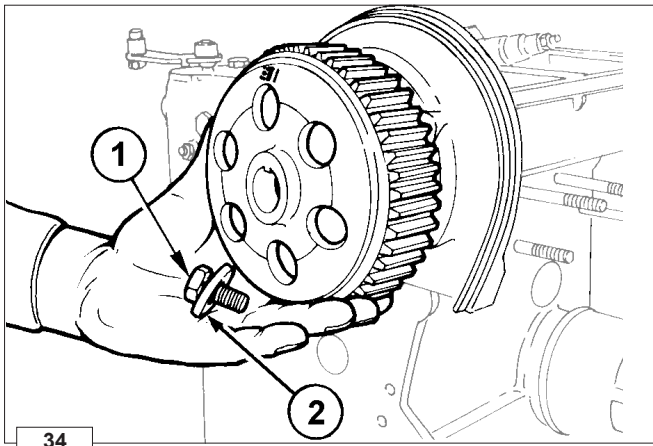

Camshaft timing pulley

Camshaft timing pulley - Disassembly/Assembly

Unscrew screw 1 and remove the pulley. No extractor is needed.

- When refitting tighten the screw at a torque of 80 Nm.

Note: Assess any wear caused by the lip of the seal ring on the pulley tang.

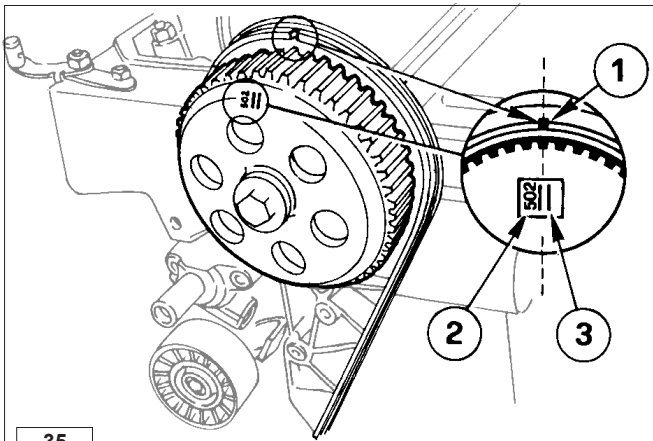

Camshaft timing pulley - Reference marks

- 1 Timing reference mark on cylinder head.
- 2 Camshaft pulley timing mark
- 3 Camshaft pulley timing mark, for KDW, 702, 1003, and 1404 engines.

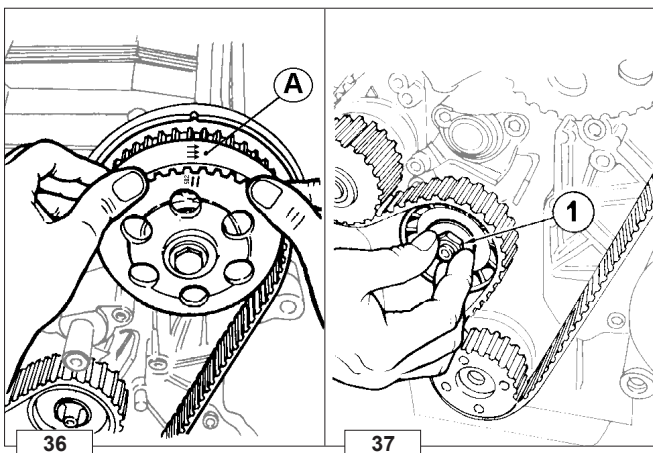

Camshaft timing

Camshaft timing - Belt Reassembly



Important

Remove the distributor toothed belt from its protective wrapping only when mounting it.

Make the connections for toothed belt fig. 33 and that of pulley fig. 34 fit together.

Insert the belt (as in figure 35) taking account of the direction of the arrows **A** impressed on it (direction of rotation).

Tighten the nut **1** by hand until the belt tightener rests on surface of the crankcase.

Start by mounting the camshaft pulley belt, then mount crankshaft's pulley.

Do not mount driven belts.

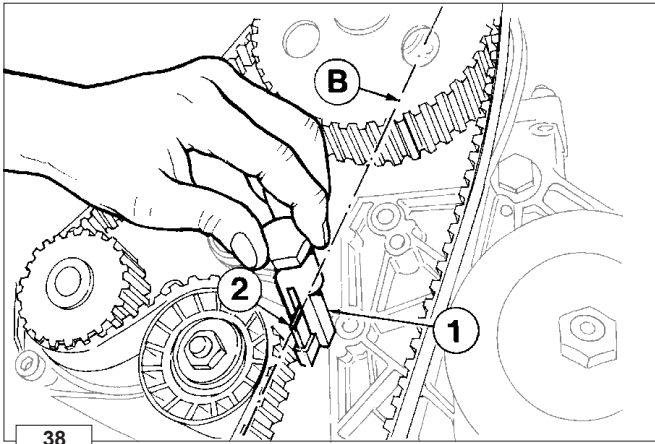

Camshaft timing - Belt tightening tool

Position belt preload tool 7107-1460-049 **1** over the timing belt idler adjustment ear **2**.
See "Camshaft timing - Belt Tightening and Fastening".

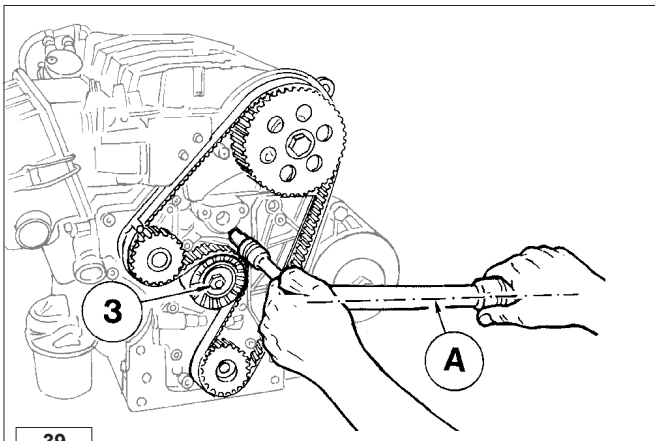

Camshaft timing - Belt Tightening and Fastening

Insert the torque wrench in the suitable tool so that the **A** axis of the key fig. 39 is at 90° to the **B** axis of the tool in fig. 38.
Tighten in clockwise direction at 20 Nm.
Remounted the drive pulley.

- Maintaining the belt tension, tighten nut **3** with another torque wrench at 40 Nm,

Rotate the crankshaft a few times and check that the tension is as described above.

The check must be carried out with the appropriate Nippon Denso tension measuring instrument (halfway along the longest section of the belt), the value for a cold engine must be 15±2Kg.

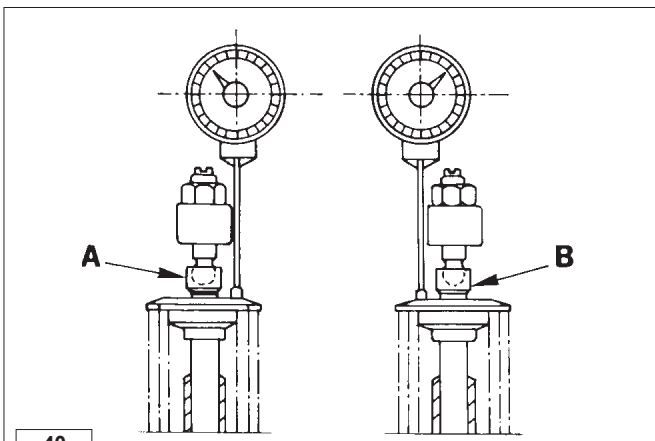

Valve timing check

- A** = Intake valve
- B** = Exhaust valve

Rotate the engine in the normal direction of rotation until the No. 1 piston (flywheel side) approaches TDC- compression stroke
Check the balance of intake and exhaust valves **A** and **B** placing the two micrometers testers on the valve collars.

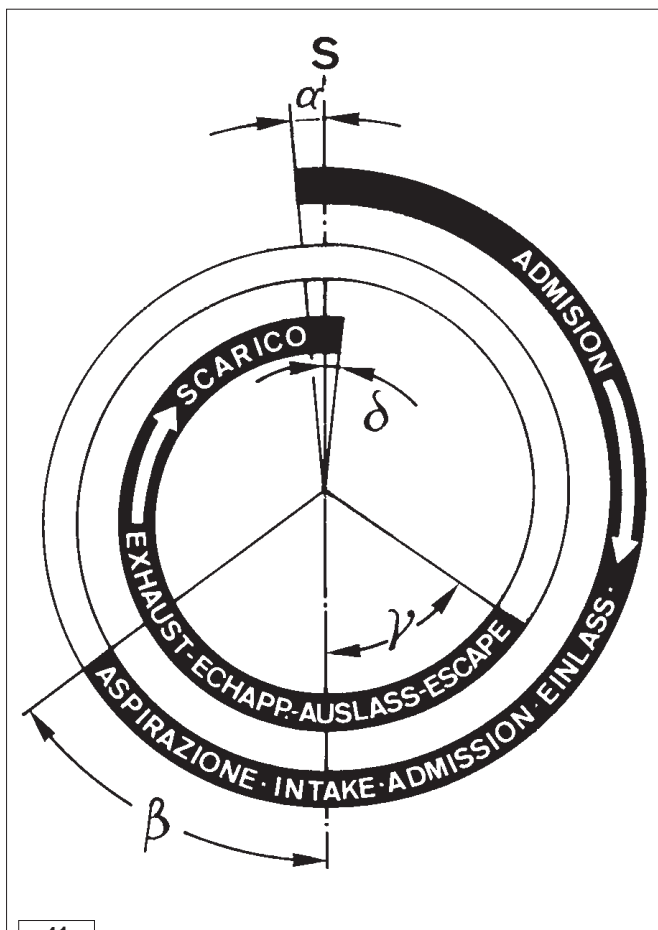

Valve timing - Angles

The angle values are determined by turning the driving shaft clockwise.

S = Piston at top dead centre
I = Piston at bottom dead centre

α = Intake valve open
 β = Intake valve closed
 γ = Exhaust valve open
 δ = Exhaust valve closed

Timing angles for operating purposes
 (valve clearance = 0.25 mm)

α = 16° before S
 β = 36° after I
 γ = 36° before I
 δ = 16° after S

Timing angles for checking puposes
 (valve clearance = 2 mm)

α = 21° after S
 β = closes in I
 γ = 2° after I
 δ = 20° before S

41

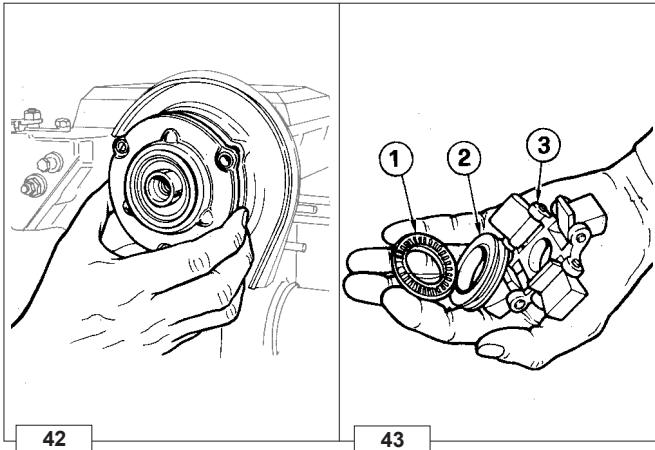

Speed governor

The weight-type mechanical governor, is driven directly by the camshaft and is housed with the cylinder head.

Components:

- 1 Thrust washer
- 2 Spool
- 3 Flyweight assembly

Note: In engines with the minimum/maximum (see fig. 49) the weights are lightened by 25%.

Speed governor components

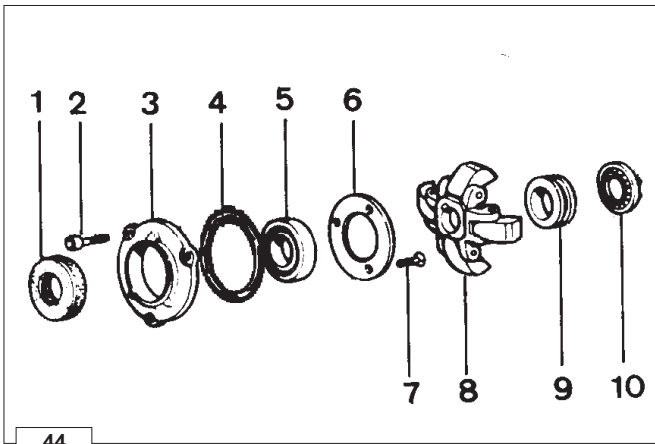

- 1 Oil seal
- 2 Screw
- 3 Support
- 4 O-Ring
- 5 Bearing
- 6 Retainer
- 7 Screw
- 8 Flyweight assembly
- 9 Spool
- 10 Thrust washer

Governor springs

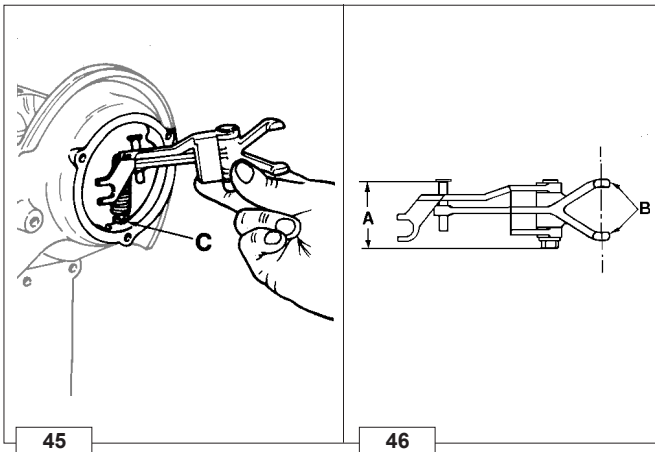

Unscrew the pin that attaches it to the cylinder head. To remove it as shown in the figure it is necessary to dismantle the camshaft. It could also be removed from the accelerator box side by unscrewing the torque gearing device. Before reassembling it, check value **A** (45 to 46 mm) and the parallelism of the two levels **B** that must not exceed 0.05 mm.

Note: There are 5 different types of regulator springs **C**. These change according to the engine adjustment: standard spring for 3,600 rpm, for 3,000 rpm, for 2,400 to 2,600 rpm, for 1,800 rpm and for 1,500 rpm.

Governor springs for Gensets

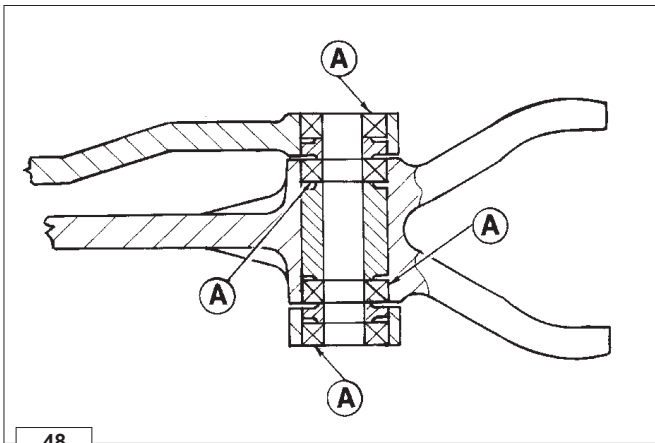

In the section view of the leverages the 4 ball bearings **A** are highlighted. They are mounted on engines for generator sets adjusted at 1,500÷1,800 rpm and on other particular applications on request.

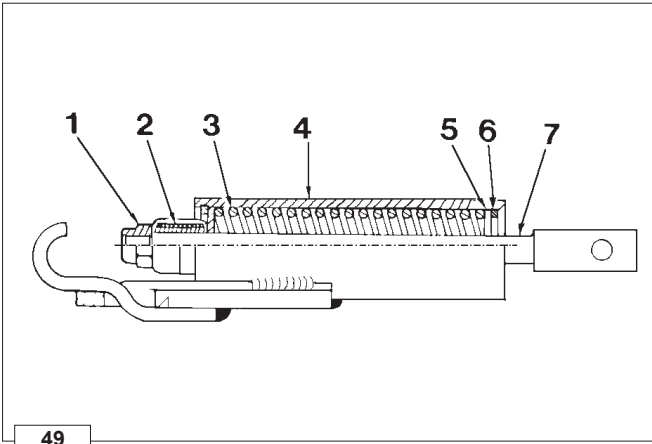

49

Speed governor - Limiting speed governor

With applications for the automotive sector the regulator spring (C fig. 45) is replaced by a device (plunger barrel) that only enables a constant speed at the minimum and maximum rpm rating.

Components:

- 1 Nut
- 2 Idle speed spring
- 3 Max. speed spring
- 4 Case
- 5 Register
- 6 Spring ring
- 7 Actuation rod

Note: There are six maximum springs in a different colours, to distinguish them from the six respective adjustments.

Red color for	3000 giri/1'
No color	3200 giri/1'
Black.....	3600 giri/1'
Orange.....	3750 giri/1'
White	4200 giri/1'
Green.....	4300 giri/1'
Brown	4500 giri/1'

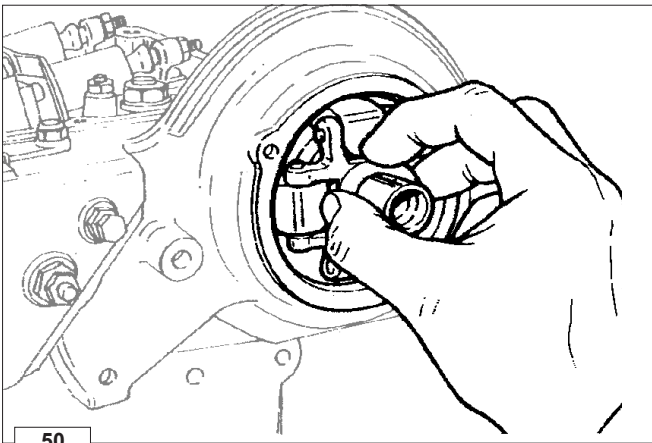

50

Speed governor - Reassembly



Caution – Warning

While reassembling, check the integrity of the components and check that they operate correctly.

Bad operation of the speed governor can cause serious damage to the engine and to people being near to it.

Remount in reverse order to Fig. 44.

When inserting the bearing in the camshaft, do it so that the four blocks enter opened, so that they can receive the hose and close over it.

Check the integrity of the sealing rings of the cover.

- Tighten the three screws at a torque of 10 Nm.

Note: With the speed governor mounted the camshaft axial clearance should be zero.

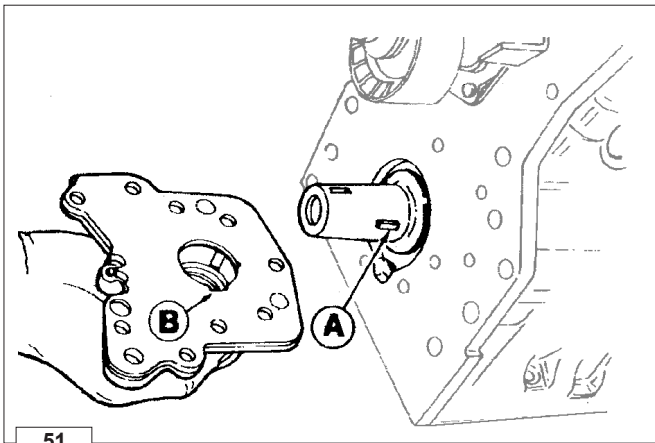

Oil pump

Oil pump - disassembly

KOHLER therefore recommends that the oil pump be handled as an assembly from a service standpoint
 KOHLER does not recommend that the oil pump be disassembled, then reassembled for purposes of installation on the engine except during emergency situations.

Rotate the crankshaft until the crankshaft timing pulley keyway is vertical as shown. Remove the oil pump assembly retaining bolts. When the crankshaft timing pulley keyway is vertical, the oil pump drive keyway **A** will be at 3:00 o'clock allowing removal of the oil pump assembly via relief **B**.

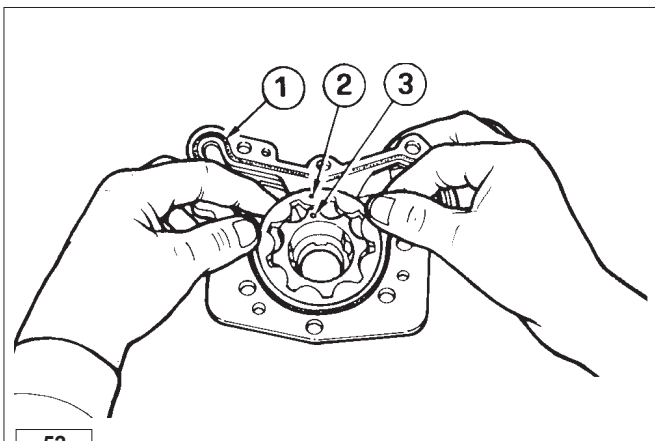

Oil pump - Reassembly

The pump rotors should be coupled on the same side, see references **2** and **3**.
 Replace the O-ring **1**.

○ Tighten the fastening screws to the crankcase at 25 Nm and those of the plate at 10 Nm.

➔ See page 79 for technical details.

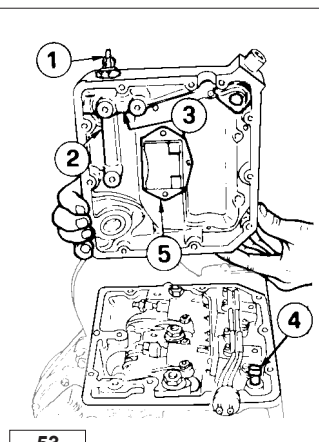
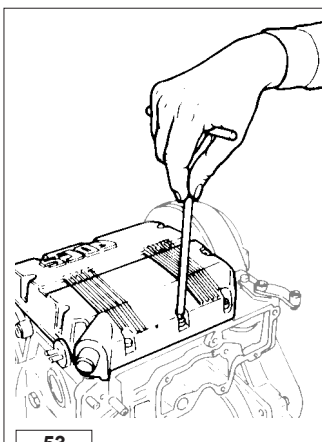

Rocker arm cover

The engine control components are all on the cylinder head.
 The cover contains part of the lubrication duct of the camshaft and of the rocker arms, as well as part of the engine vent system.

Components:

- 1 Oil pressure switch
- 2 Camshaft lubrication port
- 3 Rocker arm lubrication port
- 4 Oil exhaust hose from sump vent system
- 5 Air valve with oil decanting wire gauze

Important

During remounting be careful with oil exhaust hose **4** that needs to be properly inserted into its housing on the cylinder head.

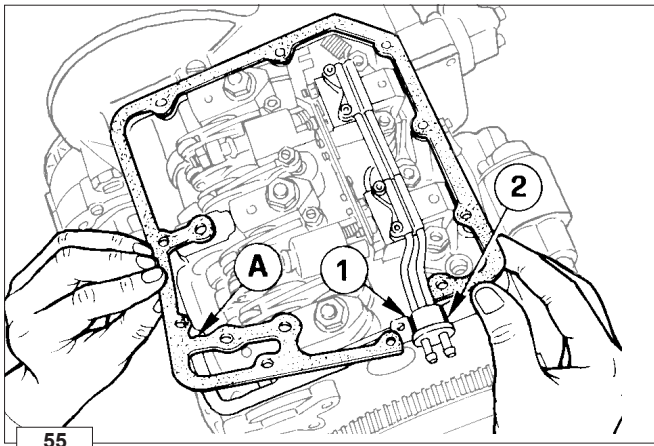

55

Rocker arm cover gasket

The rocker arm cover gasket **A** ensures the seal of the lubrication circuit for the camshaft and rocker arm shaft. Always replace it and mount it with especial care above all in zones **1** and **2** where, for greater safety, it is advisable to apply a few drops of silicon sealant.

- Tighten the rocker arm cover screws at a torque of 9 Nm.

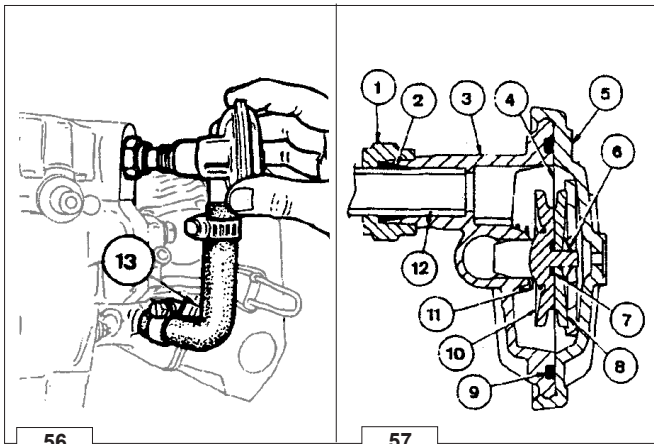

56

57

Crankcase vacuum regulator valve

Components:

- 1 Gland Nut
- 2 Bushing
- 3 Body
- 4 Diaphragm
- 5 Cap / Cover
- 6 Clip / Lock
- 7 O-Ring
- 8 Washer
- 9 O-Ring
- 10 Valve
- 11 Spring
- 12 Tube
- 13 Hose

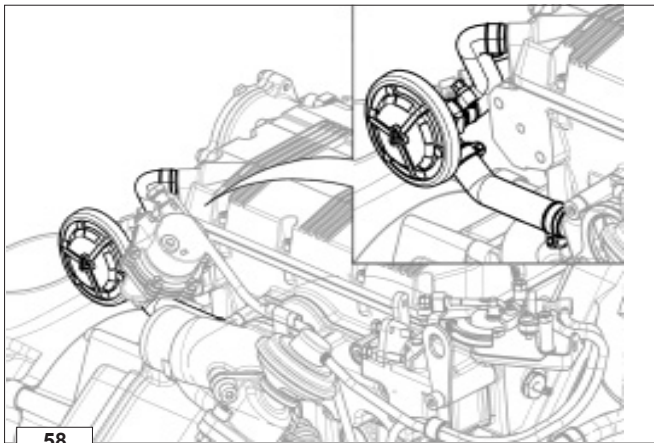

58

The vacuum relief valve is an engine safety device. Its function is that of limiting the vacuum whenever it tends to increase. Without this, should the air filter be clogged, the oil contained in the carter may be sucked back into intake manifold causing the condition for engine runaway.

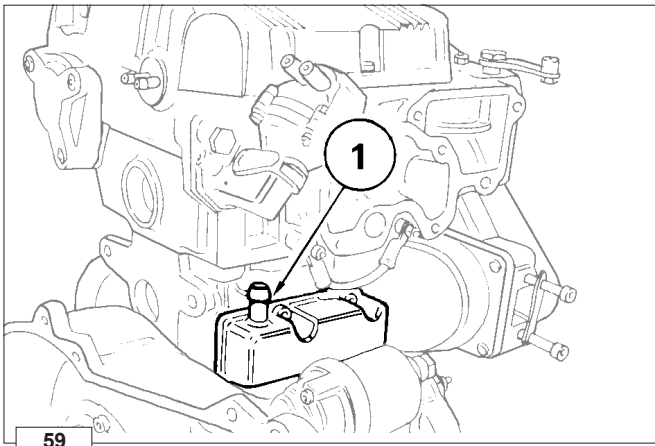

Crankcase breather

For KDW 702-1003-1404 engines, the exhaust gases exit from the cylinder head cover (see Fig. 53, 54).

Remove the cover, check the integrity of the air valve and oil decanting wire gauze.

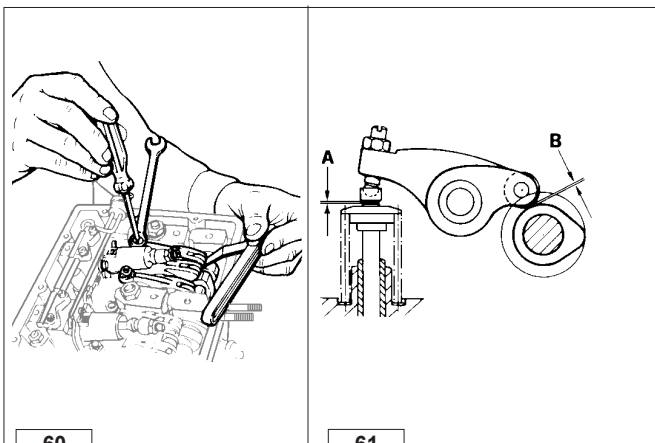

Valve / Rocker arm clearance



Important

Setting should be performed when the engine is cold.

Bring each cylinder piston to top dead center on the compression stroke and set clearance **A** at 0,20 mm for both the intake and exhaust valves.

For greater convenience, clearance check **B** is accepted. In this case the value is 0.15 mm.

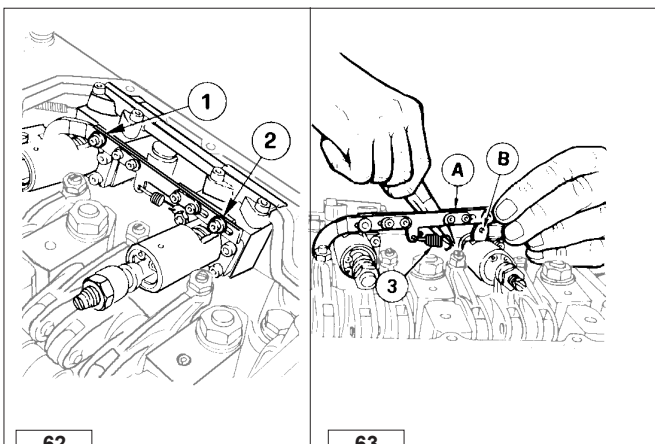

Injection pump control rod

Depending on the engine model, the injection pump control rod will link two, three, or four injectors to the engine governor.

Screws **1** and **2** are pivoted on the delivery control lever of each pump/injector **B**, unscrew the screws and remove spring **3**.

When refitting tighten the screws **1** and **2** at a torque of 1,1 Nm and make sure that they stop on lever **B** of each pump/injector and not on rod **A**.

➡ To carry out the delivery equalisation of the injection pumps see page 93.

➡ To carry out the timing of the injection pumps and speed governor see page 105

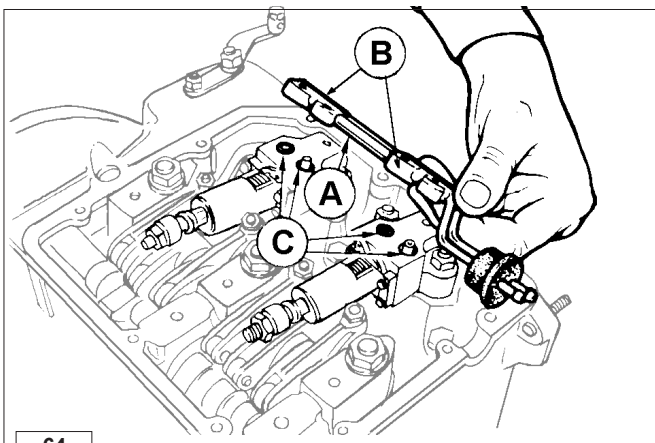

Fuel rail

When removing the fuel feeding pumps **A**, with the rail holders **B**, pay attention that the sealing O-rings **C** remain in their seats.

○ When refitting tighten the rail holder screws at a torque of 4 Nm.

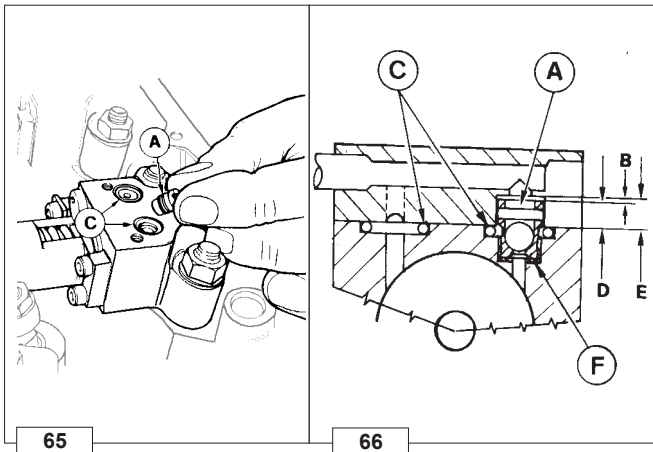

Pump/injector unit - non-return valve

Non-return valve **A** immediately stops the engine whenever the stop is activated.

Note: If the value of **B** is not achieved, the two rings **C** are not subject to enough compression to ensure the seal; any fuel loss would contaminate the lubrication oil and consequently damage the engine, **F** = metal gasket.

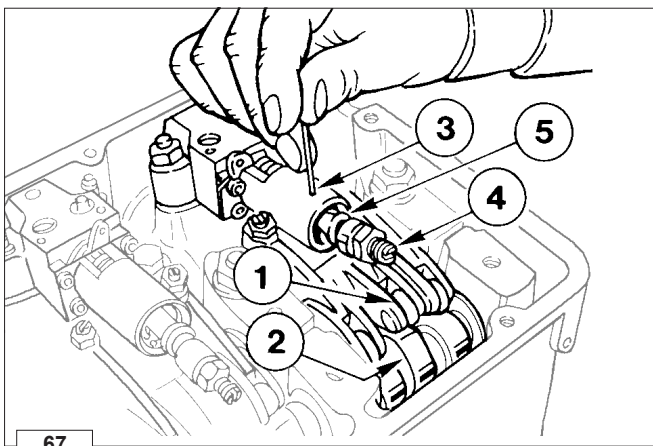

Pump/injector unit - Disassembly

When the removal (but not replacement) of a unit injector is required the following procedure may be used to avoid the need for other adjustments:

Rotate the engine until the unit injector cam lobe **2** forces the cam follower **1** to the highest position, then insert a suitable sized (hardened) pin into the hole **3** and rotate the engine until the cam follower **1** is at the lowest position. In this way the injection advance regulator **4** remains calibrated.

Important

If you dismount more than one pump/injector unit, make sure to reinstall them in the appropriate housing (with relative drive rod **5**); before mounting lubricate the drive rod at its two ends with MOLYSLIP, AS COMPOUND 40 type.

Rocker arm assembly

Remove the nuts attaching the rocker arm assembly to the cylinder head.

- When refitting tighten the nuts at a torque of 40 Nm.

The pin, that is hollow inside to allow lubrication, is closed at its ends by two caps.

Note: The rocker arm assembly may be removed without removal of the unit injectors.

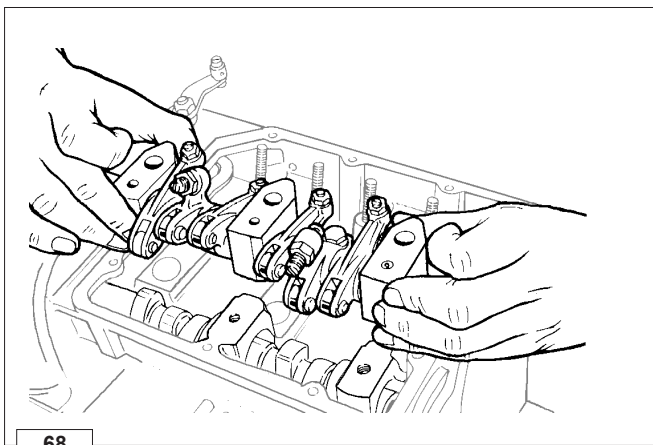

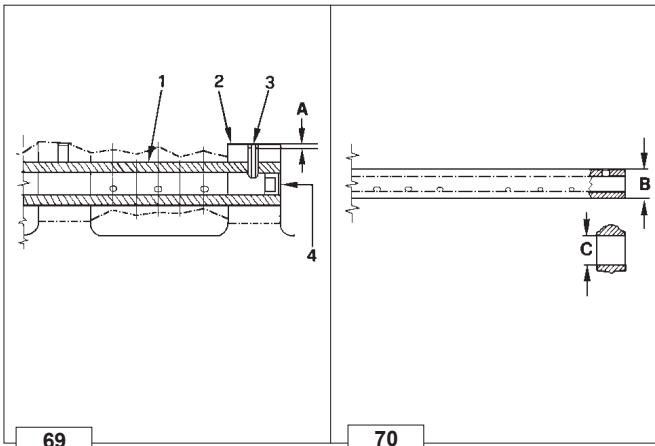

Rocker arm pivot, dismounting and remounting

To remove pivot **1** from the support **2** it's necessary to drill out pin **3** using a 4mm drill bit.

On remounting insert a new pin and reinsert it in bearing surface **A** (0 to 1 mm).

Check the rod's state of wear and tear (diam. **B**) and that of the rocker arm holes (diam. **C**).

Remove the closing caps **4** at the end and carefully clean inside.

Dimensions (mm):

	mm	C-B	C-B limit value
A	0÷1,00		
B	17,989÷18,000	0,015÷0,041	0,090
C	18,015÷18,030		

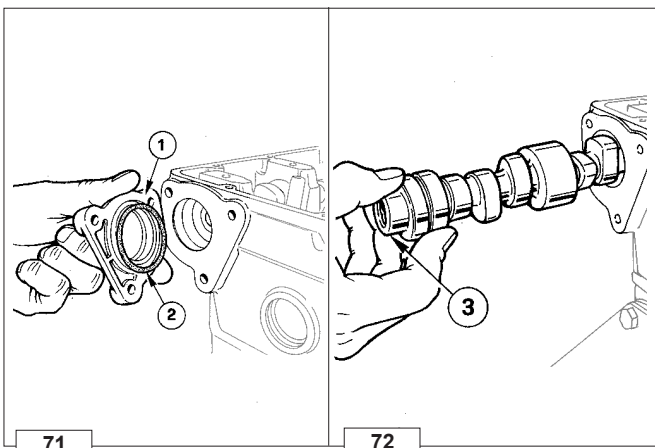

Camshaft, disassembly

Loosen the screws and remove the cover **1**.

Check gasket ring **2** for integrity.

Remove the drive rod from the fuel pump.

Gently remove the camshaft, slight rotations may be required to avoid binding the camshaft lobes against the camshaft bearing surface bores.

Note: The lift pump drive eccentric **3** is included on the flywheel end of the camshaft and fixed with a screw.

○ In case of replacement tighten the eccentric screw at a torque of 80 Nm.

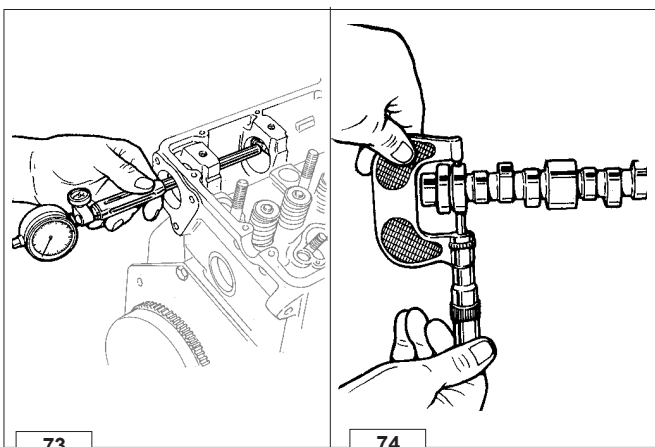

Camshaft, journal and housing measurement

Use an inside micrometer gauge for housing diameters and an outside micrometer gauge for journal diameters.

Camshaft journals and housings - Dimensions (mm)

A	B	A-B	A-B limit value
37,035÷37,060	36,975÷37,000	0,035÷0,085	0,170

Note: The camshaft journal and cylinder head camshaft bore dimensions are identical for all KDW-FOCS series engines

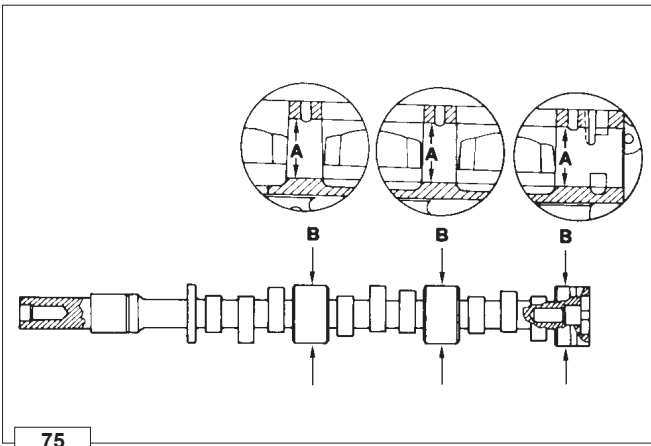

Camshaft lobe measurement

Use an outside micrometer gauge.

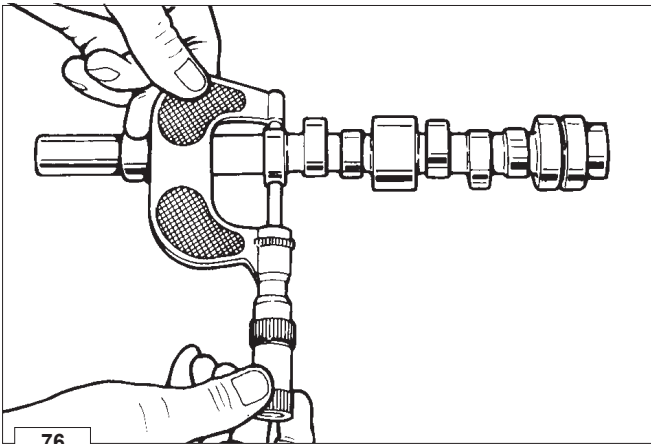

Intake / Exhaust / Injection camshaft lobe height

All engines in the series have intake exhaust and injection cams with the same height of **H** and **H1**. If wears on the cams exceeds by 0.1 mm the minimum value given **H** and **H1**, replace the crankshaft.

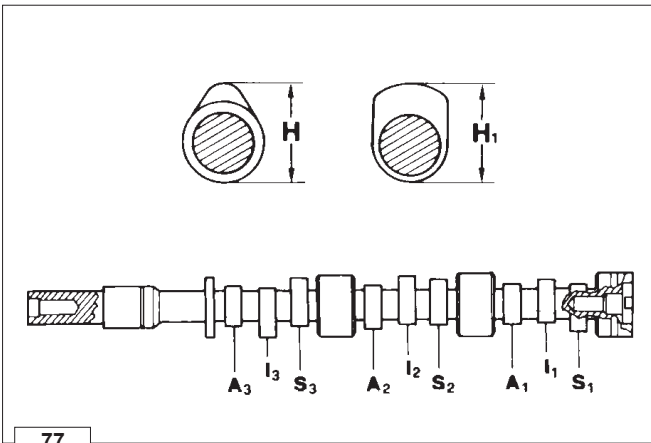

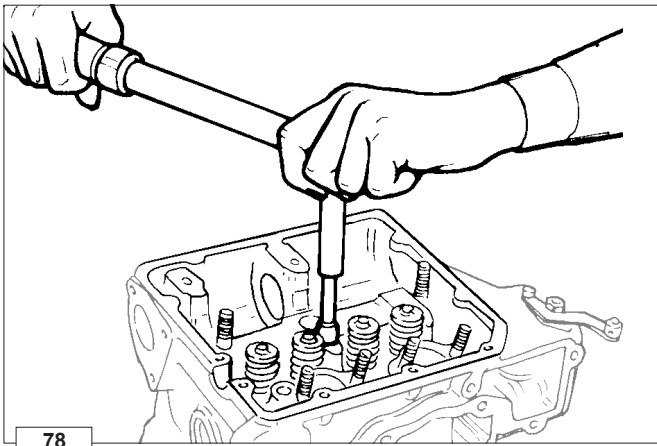

CYLINDER HEAD, removal



Important

Do not remove the cylinder head when hot to avoid deformation.

If cylinder head is deformed by more than 0.10 mm, level it off by removing a maximum of 0.20 mm.

➔ For the cylinder head tightening procedure see page 67.

78

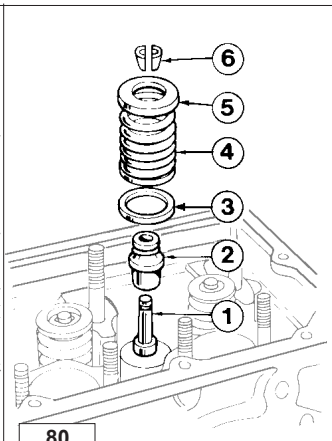
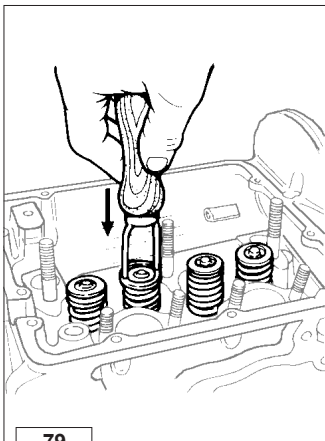

Valves

To remove the valves it is necessary to remove the collets; place a spacer under the valve head, press strongly on the spring cap as shown in the picture.

Components:

- 1 Valve stem
- 2 Valve stem seal ring
- 3 Spring seat
- 4 Spring
- 5 Spring cap
- 6 Collets

79

80

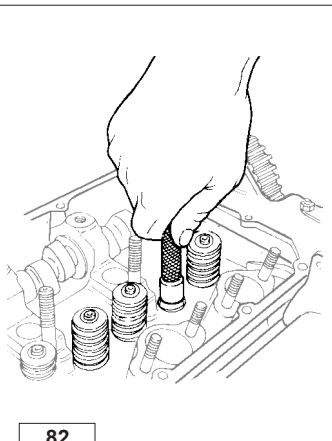
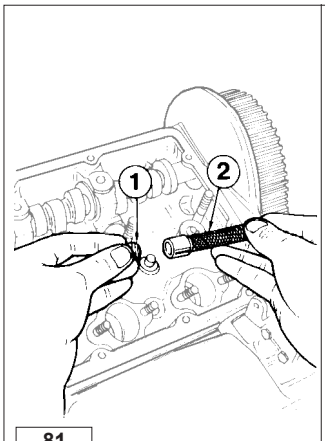

Valve stem sealing rings - Reassembly

To prevent deformation of the sealing ring 1 as it is inserted onto the valve guide, insert it onto tool "7107-1460-047" 2 (after lubricating the sealing ring) and proceed as shown in the picture ensuring that gasket 1 is completely fitted.

81

82

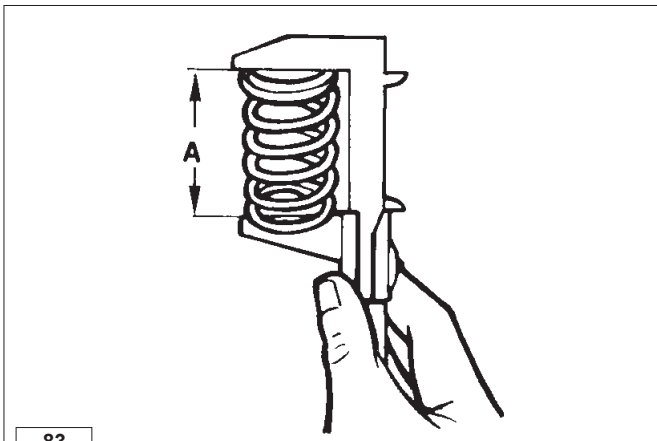

Valve springs

Measure free height with a gauge.

Free height **A** = 46 mm.

Note: If the free height **A** is less than 43,5 mm replace the spring.

83

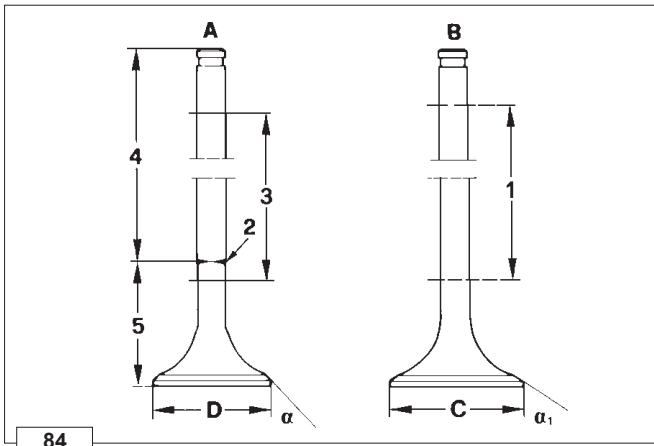

84

Valve, specifications

Exhaust valve A

Shaft and head are made of 2 different materials.

2 Welded joint

3 Chromium-plated joint

4 Portion made of: X 45 Cr Si 8 UNI 3992

5 Portion made of: X 70 Cr Mn NI N 216 UNI 3992

	702-1003-1404	α_1
D	30,20	$45^\circ 30' \div 45^\circ 45'$

Intake valve B

Material: X 45 Cr Si 8 UNI 3992

1 = Chromium-plated joint

	702-1003-1404	α_1
C	34,40	$60^\circ 30' \div 60^\circ 45'$

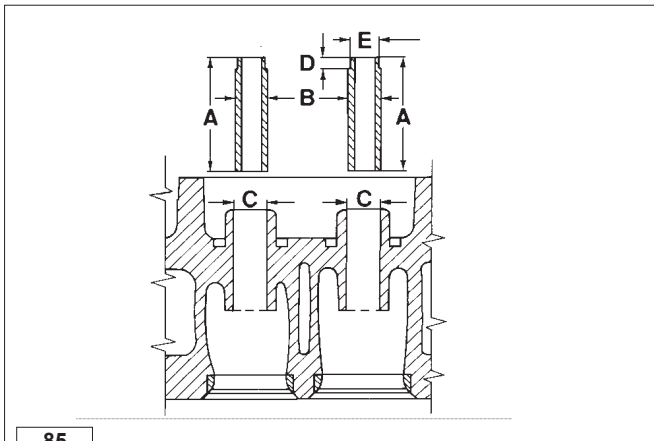

85

Valve guides and valve guide housings

Both intake and exhaust valve guides are identical dimensionally and are made from phosphoric gray iron with a pearlitic matrix:

Dimensions (mm):

A	B	C	D	E
36,4÷36,6	11,045÷11,054	11,000÷11,018	5,80÷6,20	9,75÷9,85

Note: Valve guides are supplied in finished form, further machining is prohibited.

Valve guides with outside diameter **B** increased by 0.5 mm. are available.

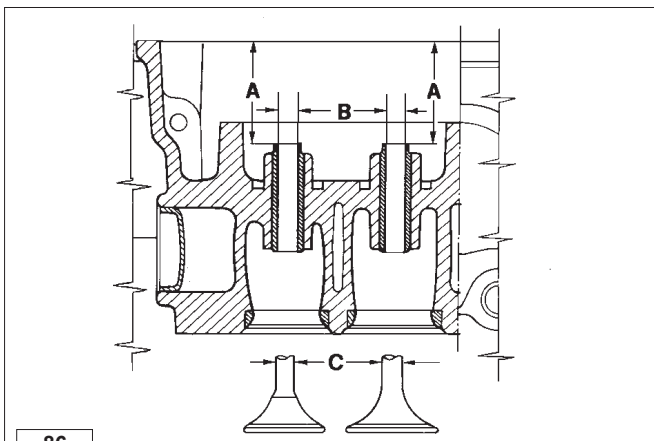

86

Valve guide insertion

Fit the guides with a punch taking account of value **A** in relation to the cylinder head surface.

Dimensions (mm):

A	B	C
39,5÷40,0	7,005÷7,020	6,960÷6,990

Clearance (mm):

(B-C) = 0,015÷0,050 (B - C) limite usura = 0,10

Valve seats and housings - Dimensions

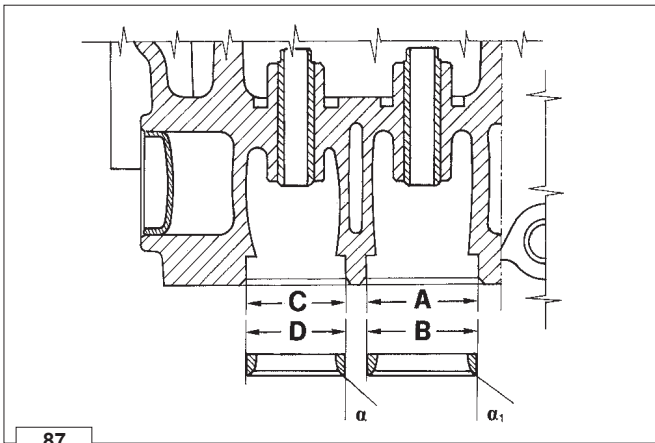

87

KDW 702-1003-1404			
	mm	α	α_1
A	35,220÷35,245	44° 53' ÷ 45°	59° 53' ÷ 60°
B	35,306÷35,315		
C	31,220÷31,241		
D	31,308÷31,316		

Press valve seats into the housings

Note: Valve seats are supplied in finished form, further machining is prohibited.

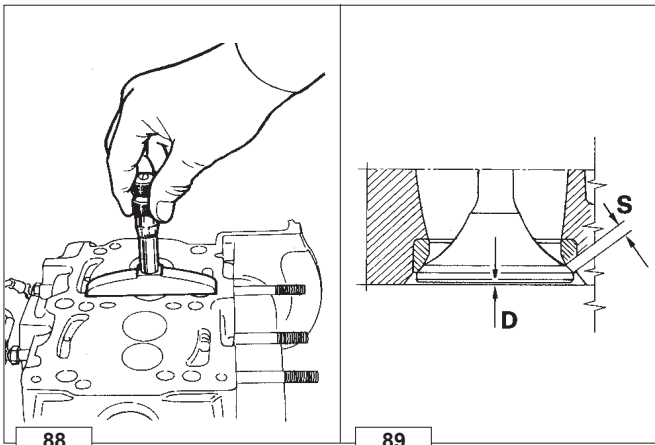

88

89

Valve recess and seat sealing width

Dimensions (mm):

KDW 702-1003-1404		
	mm	
D	0,7÷1,0	1,3
S	1,6	2,0

Grind valve seats with fine emery paste.
After grinding check the valve recess **D** relative to the cylinder head surface and the seat sealing width **S**.

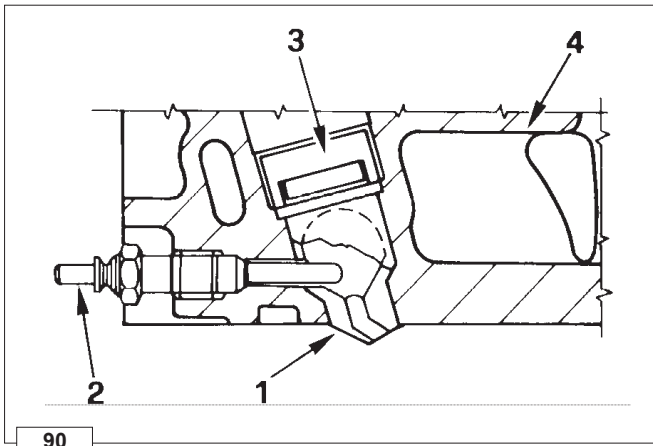

90

Pre-combustion chamber

Components:

- 1 Pre-combustion chamber
- 2 Pre-heating glow plug
- 3 Pre-combustion chamber ring nut
- 4 Cylinder head

The pre-combustion chamber does not normally require removal or service, if service is necessary follow the procedure described below.

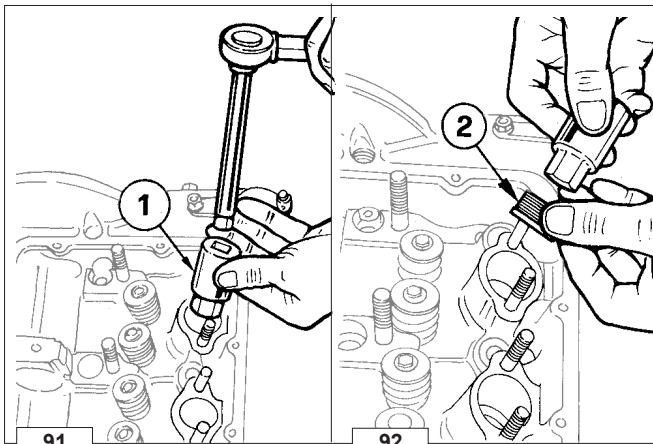

91

92

Pre-combustion chamber ring nut removal

The pre-combustion chamber is fixed to the cylinder head by a ring nut, so before removing the pre-combustion chamber it is necessary to unscrew the pre-combustion chamber ring nut. Use the special tool "7107-1460-027" 1 to remove the ring nut 2.

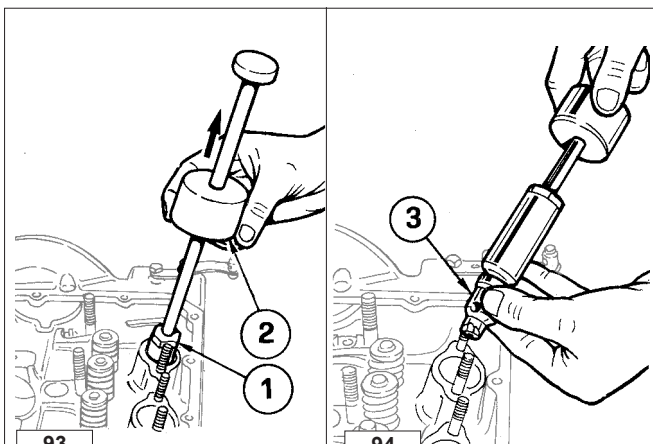

93

94

Pre-combustion chamber, removal

Before proceeding with removing the pre-combustion chamber it is necessary to remove the pre-heating glow plug. Screw special tool "7107-1460-030" 1 into the pre-combustion chamber.

Carefully, but sharply, slide the slide hammer 2 up the special tool shaft until contact is made with end of the tool. The hammer effect of the special tool will extract the pre-combustion chamber 3.

Note: There are many types of precombustion chambers for the various engines described as follows.

- KDW 702-1003-1404.

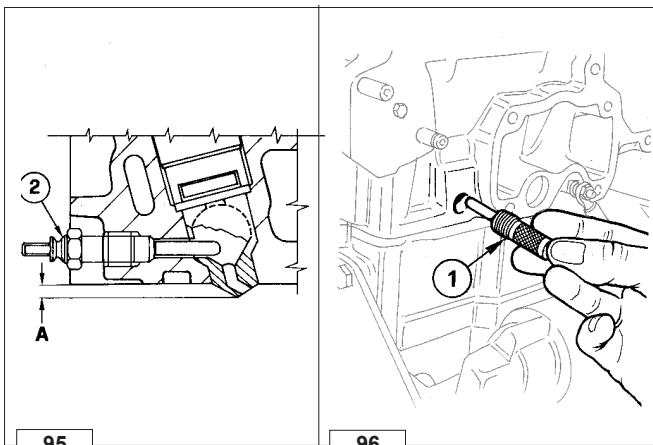

95

96

Pre-combustion chamber, installation

The pre-combustion chamber has a hole on the side where the pre-heating glow plug 2 must be inserted.

When re-fitting introduce the the new pre-combustion chamber into the cylinder head so that the side hole of the pre-combustion chamber aligns with the glow-plug hole.

To make sure that both the holes align appropriately use tool "7107-1460-031" 1 inserting it into the glow-plug hole.

- Tighten the ring nut twice:
1st tighten at a torque of 100 Nm,
2nd tighten at a torque of 180 Nm.

Check that clearance A is 3,68±4,1 mm.

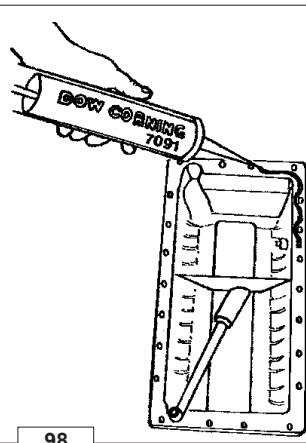
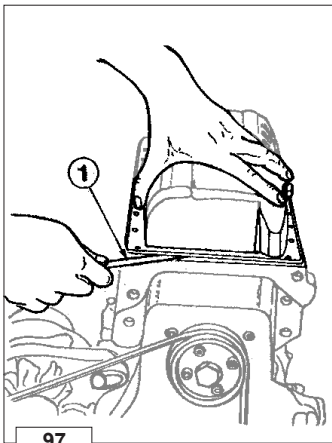

Oil pan, removal

! Danger - Attention

- The used engine oil can cause skin-cancer if kept frequently in contact for prolonged periods.
- If contact with oil cannot be avoided, wash carefully your hands with water and soap as soon as possible.
- Do not disperse the oil in the ambient, as it has a high pollution power.

Remove the fixing screws.
Insert a spacer 1 in the forward and rear main bearings.
Detach the silicon from the main bearing rubber bulb seals.

When re-mounting apply Silicone " Dow Corning 7091" as shown in the picture.

○ Tighten the screws at a torque of 10 Nm.

Before starting the engine make sure that:

- 1) the oil drain plug is tightened correctly
- 2) the engine has been refilled with the prescribed quantity of oil (see page 34).

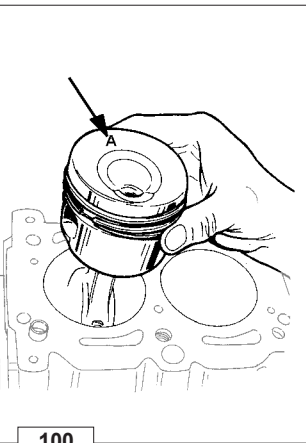
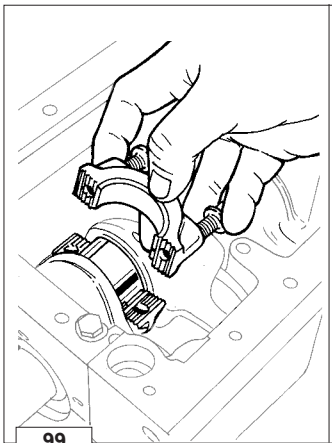

PISTON

Remove the connecting rod big end cap.
Remove the piston-connecting rod assembly.

Note: The Ricardo type of combustion chamber is used for KDW 702-1003-1404 engines.

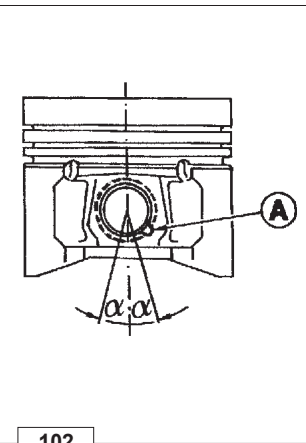
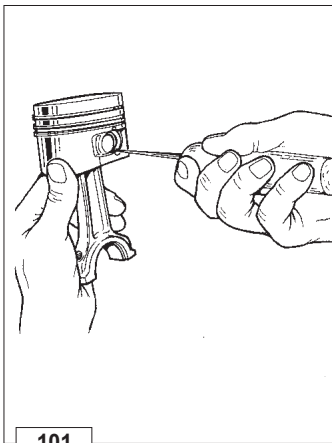

Stop pin rings, dismounting and remounting

Extract the ring inserting a pointed tool in hollow A.

On remounting, insert rings with the points turned downwards inside the corners ($\alpha = 15^\circ$).

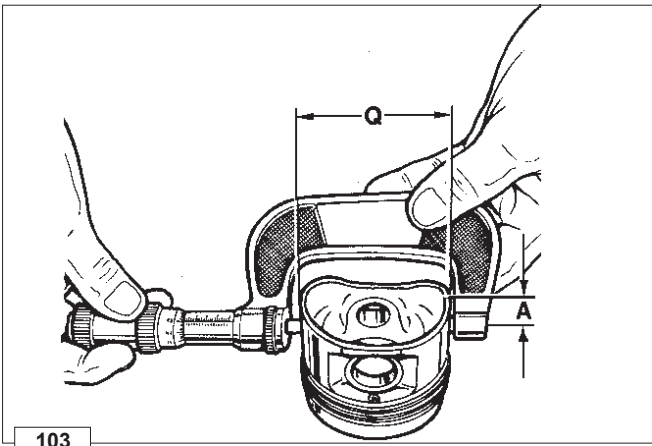

103

Piston, disassembly and inspection

Remove the stop rings and remove the pin, see fig. 101.
 Remove the piston rings and clean the slot.
 Measure diameter **Q** at height **A** from the base of skirt (**A** = 9 mm).
 If the diameter is worn more than the 0.05 mm minimum given value, replace piston and rings.

Note: The provided oversize elements are of 0.50 mm and 1.00 mm

Piston, class

The pistons are subdivided according to their diameters into categories: **A**, **B**, **C**. These references, are shown on the top of the piston (see fig. 100).

KDW 702-1003-1404			
Class	Ø Cylinder - mm	Ø Piston - mm	Clearance - mm
A	74,990÷75,000	74,930÷74,940	0,050÷0,070
B	75,000÷75,010	74,940÷74,950	
C	75,010÷75,020	74,950÷74,960	

Piston supply:

Pistons at the nominal diameter are only supplied in category **A**.
 Pistons oversized by 0.50 and 1.00 mm are supplied with reference to the increased level on the piston crown:
 Ø 75.5 – 76.0 for KDW 702-1003-1404 engines.

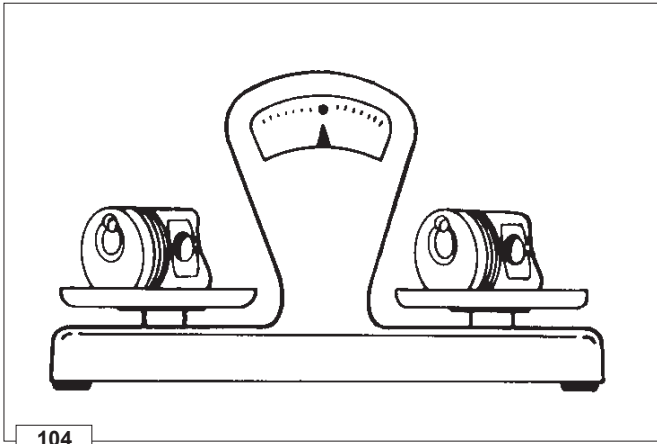

104

Piston, weight

Weigh pistons when replacing them in order to avoid unbalance.



Important

The difference in weight should not exceed 4 g.

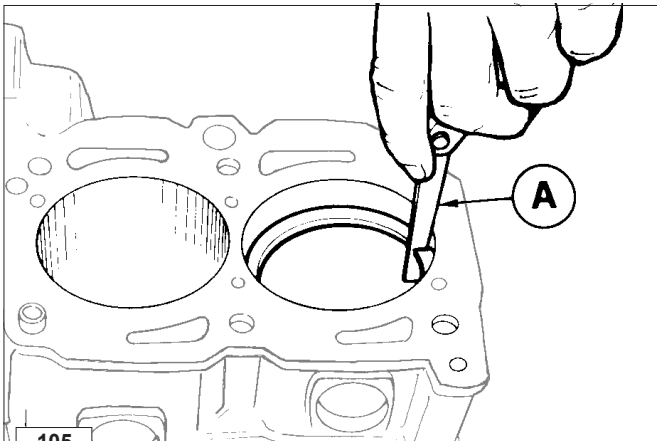

105

Piston rings - End gaps (mm)

Place piston rings squarely into the unworn part of the lower cylinder and measure the end gap **A**.

Piston ring	A	limit value
1°	0,25÷0,45	1,0
2°	0,25÷0,45	
3°	0,25÷0,45	

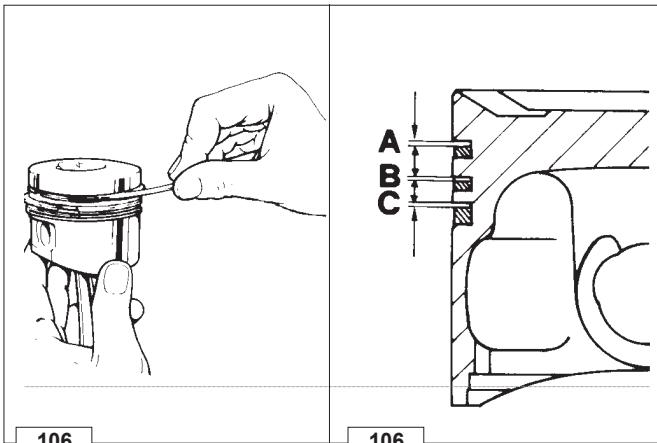

106

106

Piston ring, Clearance between grooves (mm)

A	0,090÷0,125
B	0,050÷0,085
C	0,040÷0,075

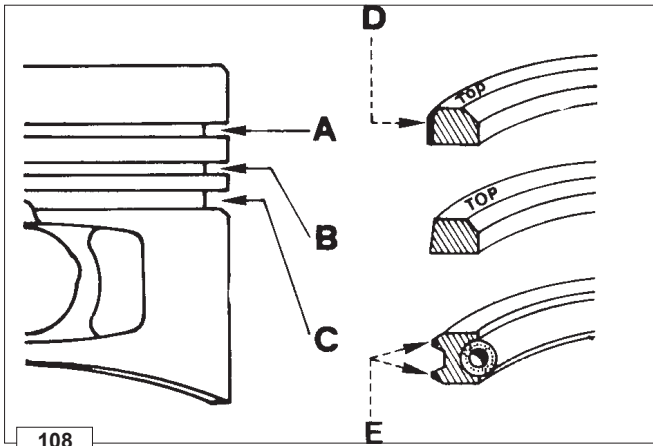

108

Piston ring, mounting order

- A = 1° ring (internal tapered and torsional)
- B = 2° ring (internal tapered and torsional)
- C = 3° Oil control ring
- D = Chrome-plated area
- E = Chrome-plated area

Note: When there is writing on the surface of a piston ring, mount that surface with face upward.

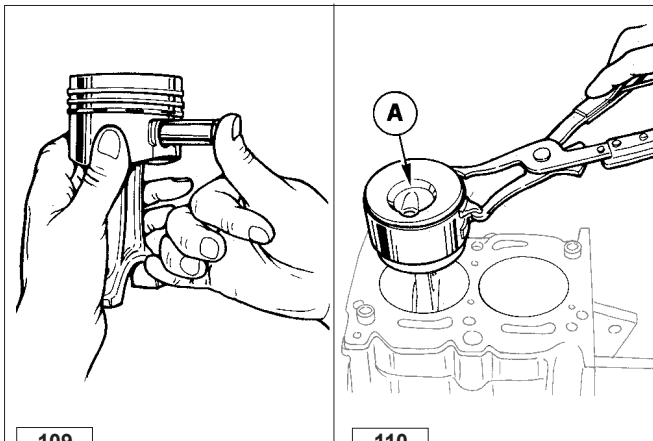

109

110

Piston, assembly



Important

Before re-mounting lubricate the piston pin, piston, cylinder and connecting rod big end bearing.

Couple the piston to the connecting rod inserting the pin, after lubricating it, just via thumb pressure. Insert the two pin stop rings and check that they are properly housed in their seats (see fig. 101). Using piston ring compression pliers, introduce the piston into the cylinder so that combustion chamber **A** is directly under the precombustion chamber parallel to the head. Couple the piston/connecting rod to the crankshaft.

➔ For tightening the head/connecting rod see fig. 115-116.

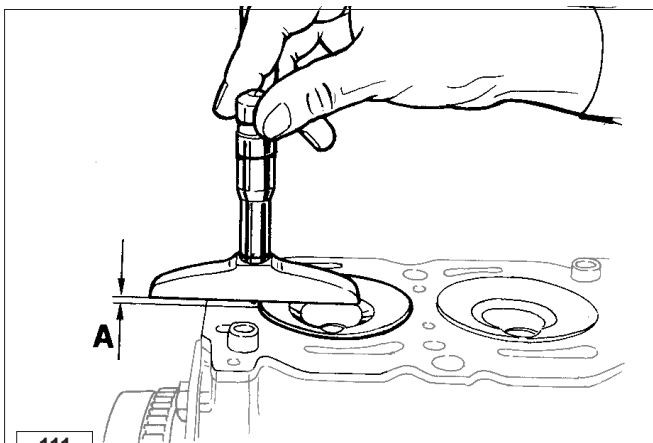

111

Piston clearance

The piston in the TDC (top dead centre) position may extend or be short of the upper surface of the cylinder. Determinare the clearance of each piston using a dial indicator to measure the difference between the two surfaces (piston crown and upper cylinder surface). To determine the piston clearance and, by consequence, which copper gaske is most suitable it is necessary to consider the **A** value of the piston that projects furthest.

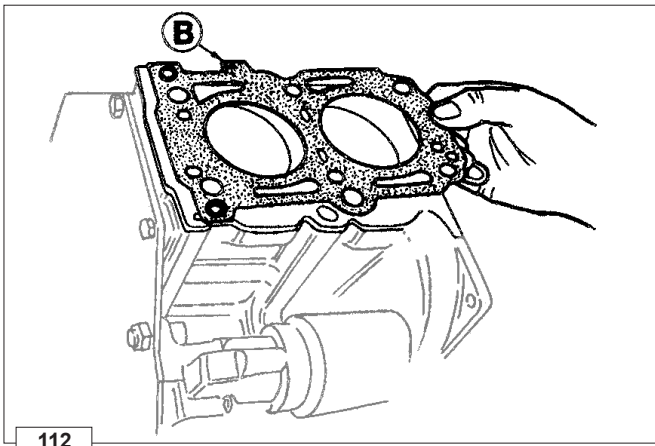

112

Head gasket

**Important**

Remove the cylinder head gasket seal from its protective covering only when you are going to mount it.

The gasket thickness is identified by the number of notches located in point **B**.

Choose the appropriate gasket considering that each **A** value on the table corresponds to a gasket with: no hole, one hole, two holes, or for the 1404 one notch, two notches, three notches.

The **A** value relates to figure 111.

Each time you dismount the head you must replace the gasket.

KDW 702-1003			
A(mm)	N° of holes		Piston clearance
0,82÷0,91	1 hole		0,54÷0,63
0,90÷1,01	2 holes		
1,02÷1,10	3 holes		0,55÷0,63
KDW 1404			
A(mm)	N° of notches		Piston clearance
0,82÷0,91	1 notch		0,52÷0,61
0,92÷1,01	2 notches		
1,02÷1,10	3 notches		0,53÷0,61

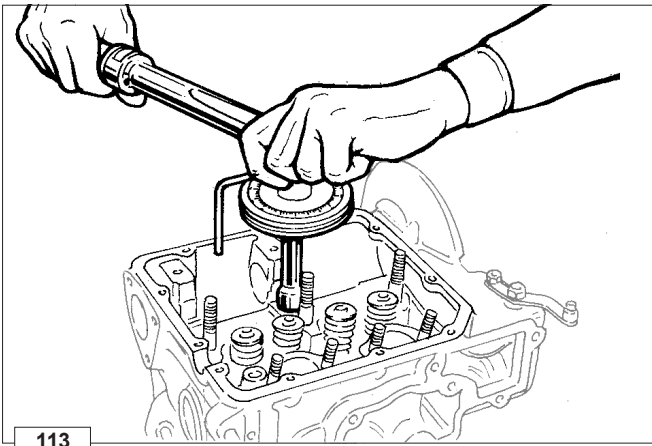

113

Cylinder head assembly

Use a torque wrench equipped with a device for angular tightening.
 Measure the length of each screw (normal length = 89.5+90.5 mm). Replace it if it exceeds 92 mm.
 Proceed as follows.

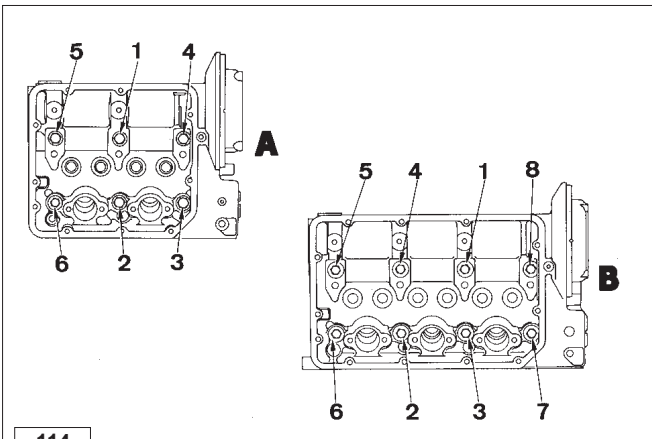

114

Cylinder head tightening procedure KDW 1003



Important

Once the head has been correctly tightened, it should not be retightened except if it is disassembled again.

A = For KDW 702 models

B = For KDW 1003 models

Following the numerical order shown in the diagram, the bolts must be tightened in three phases:

1st phase = 50 Nm

2nd phase = Rotate the wrench 90° in a clockwise direction.

3rd phase = Rotate the wrench again 90° in a clockwise direction.

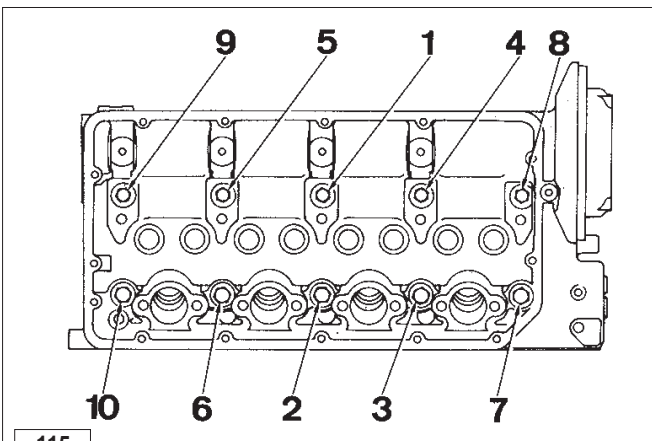

115

Cylinder head tightening procedure KDW 1404

Following the numerical order shown in the diagram, the bolts must be tightened in three phases:

1st phase = 50 Nm

2nd phase = Rotate the wrench 90° in a clockwise direction.

3rd phase = Rotate the wrench again 90° in a clockwise direction.

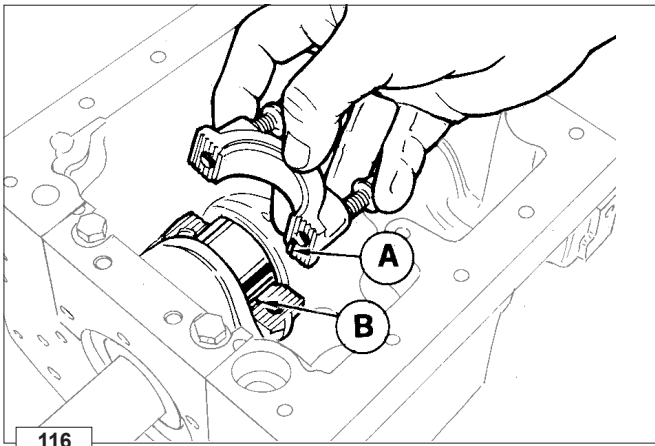

116

CONNECTING ROD



Caution – Warning

While reassembling the big end bearings, we suggest cleaning all parts thoroughly, as well as proper greasing in order to avoid risks of seizure at the first start.

Big end bearing

After connecting rod from crankshaft disconnection, check the following.

While reassembling, be sure the two centring notches **A** and **B** are on the same side.

- Tighten the connecting rod big end cap screws simultaneously at a torque of 40 Nm.

Note: The big end bearing is supplied both at the nominal value and undersized by 0.25 and 0.50 mm.

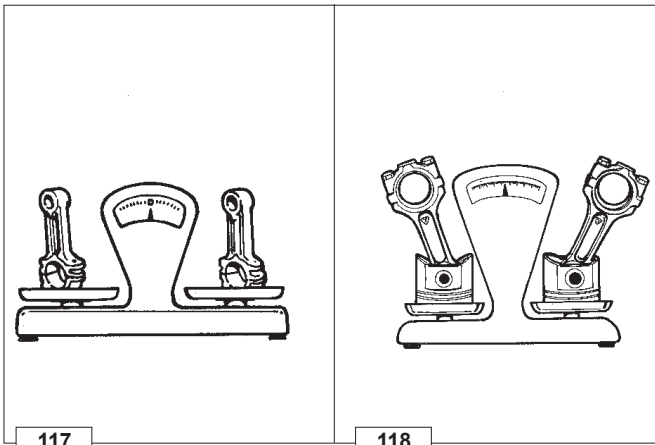

117

118

Connecting rod, weight



Important

Weigh connecting rods when replacing them in order to avoid unbalance.

The difference in weight should not exceed 10 g.

The difference in weight of the pre-assembled connecting rod, piston and pin must not exceed 14 g.

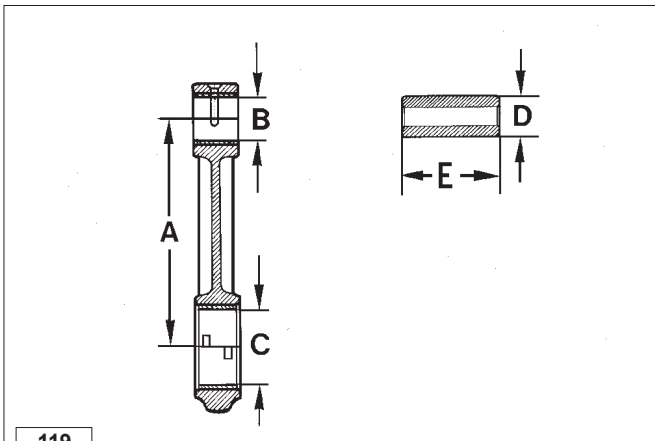

119

Connecting rod with bearings and pin

Dimensions (mm):

- A** = 126,48÷126,52 (for KDW 702-1003-1404)
- B** = 20,015÷20,025 (for KDW 702-1003-1404)
- C** = 40,021÷40,050 (bearing tightened at 40 Nm)
- D** = 19,996÷20,000 (for KDW 702-1003-1404)
- E** = 54,000÷55,100 (for KDW 702-1003-1404)
- (B-D)** = 0,015÷0,039 **(B-D)** limit value = 0,060

Nota: When driving the small end bearing make sure both oilholes are aligned.

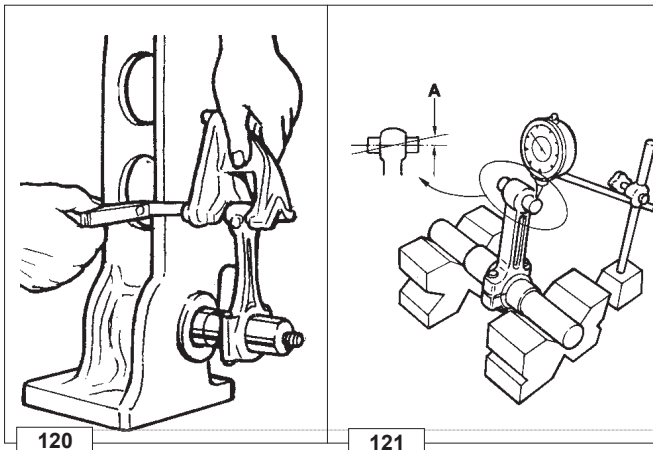

Connecting rod alignment

Use of a size corresponding with the surface plate or as a comparator in the figure.
Check the alignment of the axes using the piston pin, the gap $A = 0.015$ mm. Limit 0.030 mm.
Small deformations can be corrected in a press acting with gradual efforts.

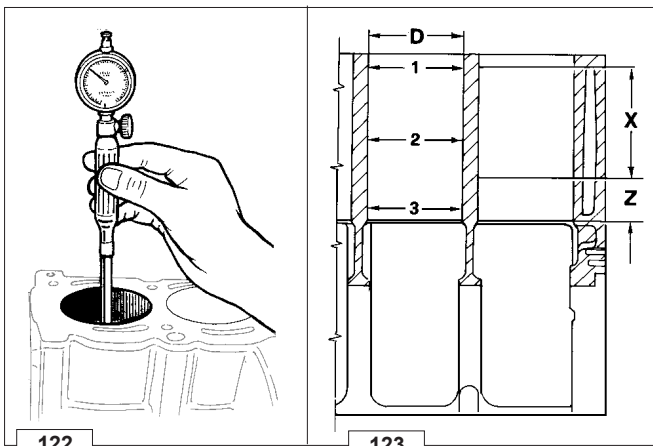

CYLINDERS

Reset the dial gauge with a calibrated ring: check the diameter D in points **1**, **2** and **3**; repeat the same operation rotating the dial gauge by 90° at the same heights.
Check any wear in zone **X** where the piston rings operate and if it is greater than the 0.05 mm max limit given adjust the cylinder to the next increased value.

75,000 mm for KDW 702-1003-1404 engines.

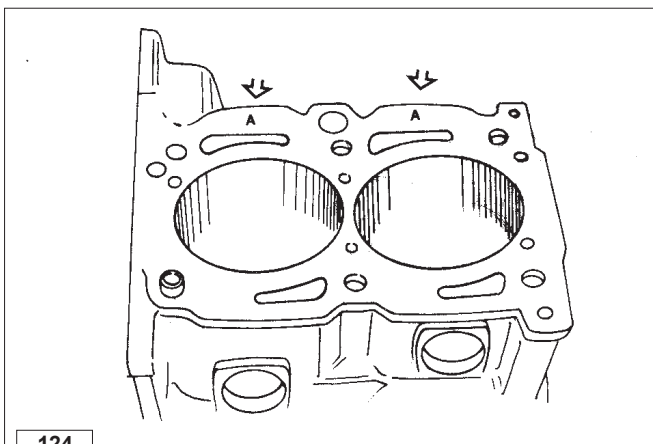

Cylinder, class

The pistons (**A**, **B**, **C**) locations are shown on the piston crown while those for the cylinders are found on the crankcase in the points shown by the arrows, see picture.

Note: The cylinders are not to be changed.

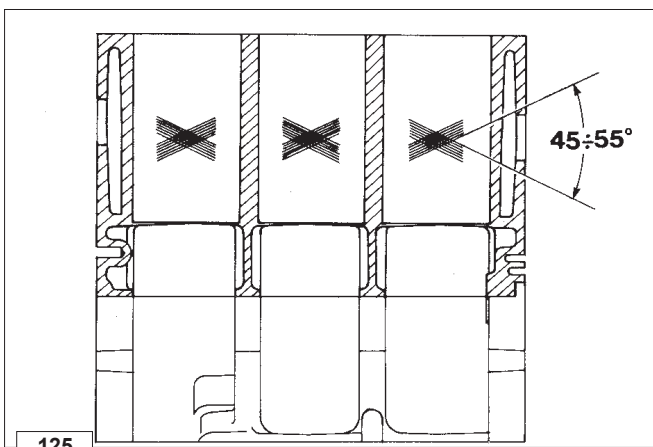

Cylinder roughness



Caution - Warning

Do not treat the cylinder's internal surfaces with an emery cloth.

The angle of the crossed processing marks must be between 45° and 55° . These must be uniform and distinct in both directions.

Average roughness must be between 0.5 and $1 \mu\text{m}$.

The whole surface of the cylinder affected by contact with the piston rings must be rendered with the plateau method.

Central main bearing caps

The central support caps are marked with locations that can be numbers as in the diagram or dots. The same locations are given on the crankcase. Couple the caps with the same references and on the same side. In any case locate the bearing's two centring notches that are to be found on the same side.

- Tighten the screws simultaneously at a torque of 60 Nm.

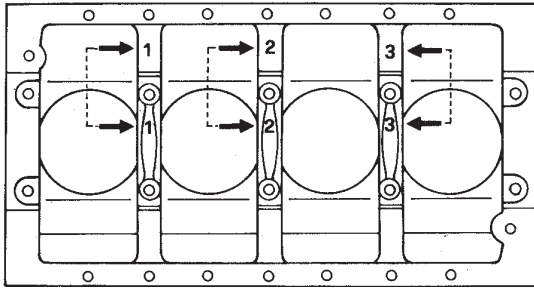

126

Rear and forward main bearing caps

Important
Before the final tightening, check the coplanarity of the two levels with a ground bar

On remounting the rear main bearing cap 1 replace the lateral rubber gaskets 2, keeping in mind that projections A and B of the support must be 0,5±1,0 mm; cut off any exceeding portions. Do the same with the front bearing cap. Before reintroducing the bearings in the crankcase, place between their surfaces two plates C and D - 0.1 mm thick - se.no.7107-1460-053.

- Tighten the screws at a torque of 60 Nm.

Note: It is advisable to apply a few drops of silicon sealant on the surface of the gasket slot 2.

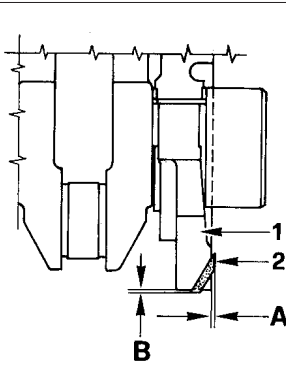

127

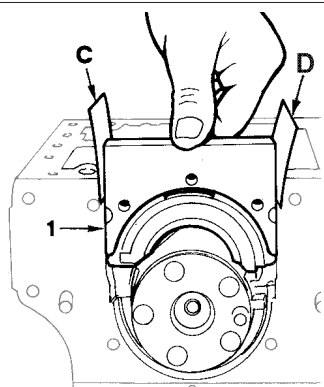

128

Check the clearances between the bearings and the journal

Use the "Perfect Circle Plastigage" type calibrated wire A and put it at the centre of the bearing with a bit of grease.

- Tighten the screws at a torque of 60 Nm.

Find out the clearance value checking the wire's compression with the appropriate graduated scale supplied in the same pack and available on the market.

- ➔ For clearance values between the journals, connecting rod pin and the relevant bearings see page 74.

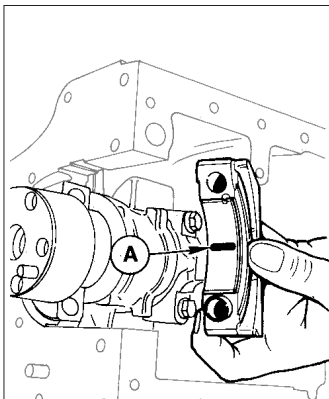

129

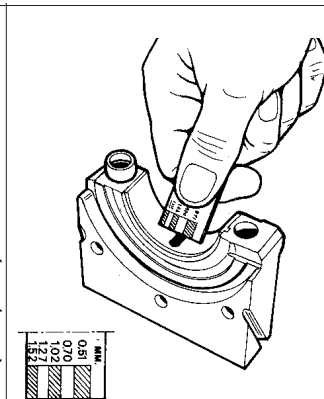

130

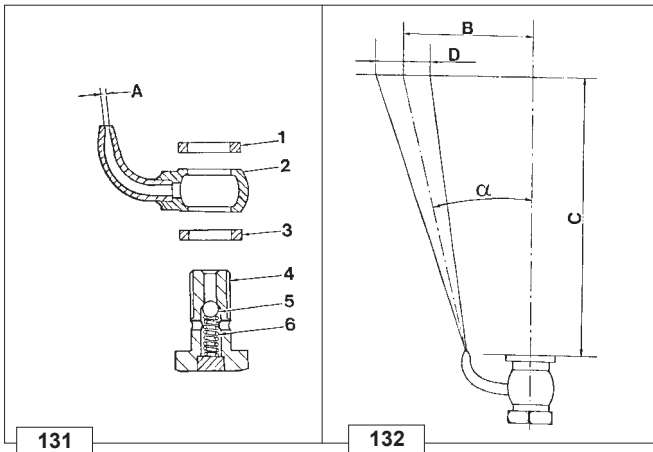

131

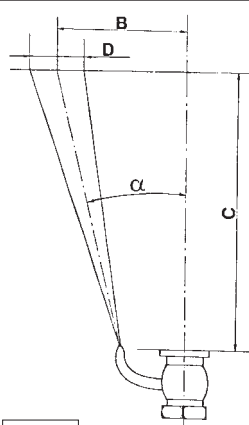

132

Piston coolant nozzles



Caution – Warning

The piston has a recess so that during up-down movements and vice versa it cannot come into contact with the nozzle.

When remounting the nozzle be careful that it is placed so that when the piston goes past it is in the centre of the recess.

Components:

- 1 Washer
- 2 Nozzle
- 3 Washer
- 4 Joint (tighten to 12Nm)
- 5 Valve (opening pressure = 1±1.2 bar)
- 6 Spring

Characteristics (mm):

A	B	C	D	α
0,80±0,85	34	150	16	5°

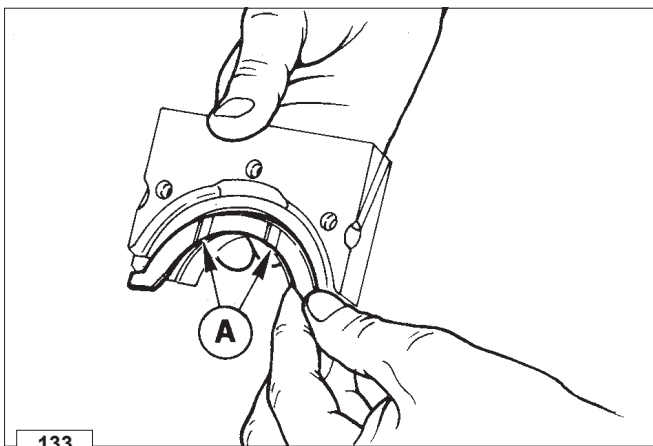

133

Shoulder half rings

So as to keep them in their seats during assembly, put a bit of grease.

The half-rings must be assembled with the slots **A** as in the figure.

Thickness of half-rings is equal to 2.31±2.36 mm.

They are supplied as spare parts as increased thickness 0.1 and 0.2 mm, see below.

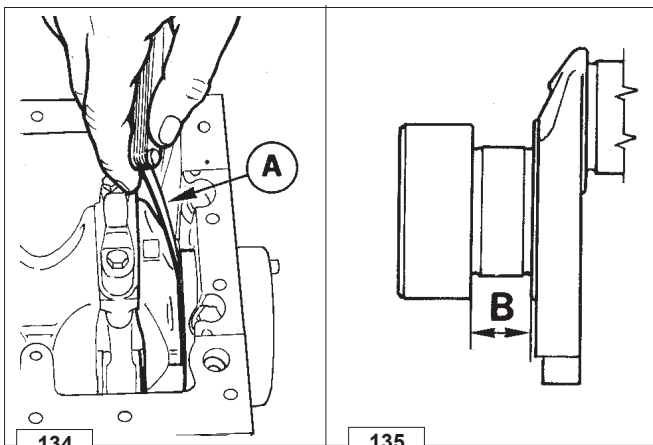

134

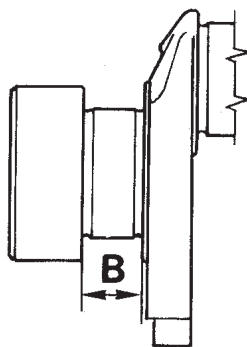

135

Crankshaft axial clearance

After tightening the main bearings measure the axial clearance **A** between the crankshaft flywheel side shoulder and the main bearing half rings.

Ref.	Clearance	Limit value
A mm	0,130±0,313	0,5
B mm	23,05±23,10	23,50

If the clearance is not within the given value check value **B**.
If need be, fit oversized half rings, see below.

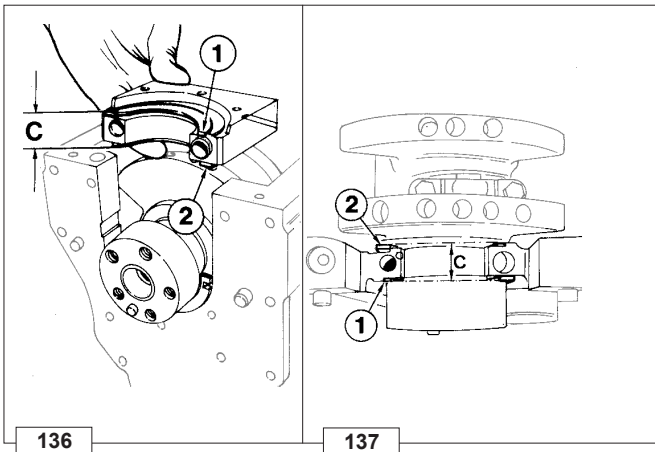

Shoulder half rings, oversized elements

Dimensions (mm):

	C	B**	A*
STD	22,787÷22920	23,050÷23,100	0,130÷0,313
1 ^a	22,987÷23,120	23,250÷23,300	
2 ^a	23,087÷23,220	23,350÷23,400	
3 ^a	23,187÷23,320	23,450÷23,500	

* A of Fig. 134.

** B of Fig. 135.

Grinding B as per relevant table, you can mount the following half rings:

1st Oversized element Half rings 1 and 2 + 0.10 mm on both sides of the bearing

2nd Oversized element Half rings 1 and 2 + 0.10 mm on one side of the support and + 0.20 mm on the other side.

3rd Oversized element Half rings 1 and 2 + 0.20 mm on both sides of the bearing.

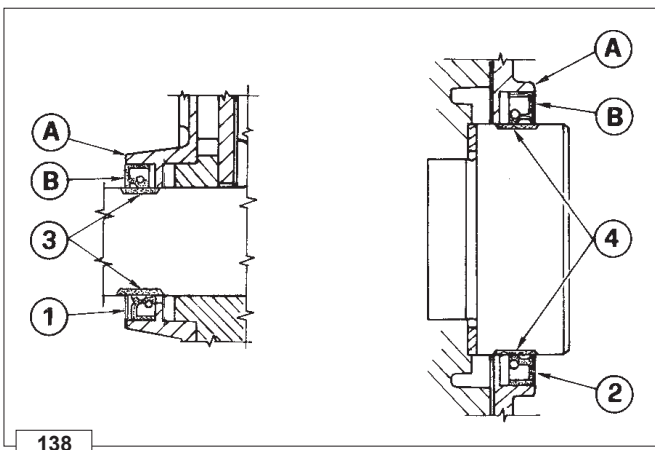

Crankshaft front and back oil seal rings



Caution – Warning

An ambient temperature below -35°C may damage the rings.

The front oil seal ring 1 inserted into the oil pump cover and the back one 2, in the flywheel side flange. If warped, hardened, or cracked, replace them.

For the replacement:

- Carefully clean the housing
- Keep the ring immersed in engine oil for about half an hour.
- Drive it into its housing with a buffer exercising a uniform pressure on the whole front surface. Be sure that the two surfaces A and B meet on the same level.
- Refill the interior hollow with grease and lubricate the seal lip with thickened oil.

Note: Before major engine overhaul, in case of oil leakage in the seal area of rings 3 and 4, you can remedy this by replacing the rings and pushing them about 2 mm deeper with respect to the previous ones.

If the rings are black it means zones 3 and 4 of the crankshaft are tempered. In this case it is necessary to remount a ring of the same colour.

If the rings are brown it means that zones 3 and 4 of the crankshaft are not tempered. In this case it is necessary to remount brown coloured rings.

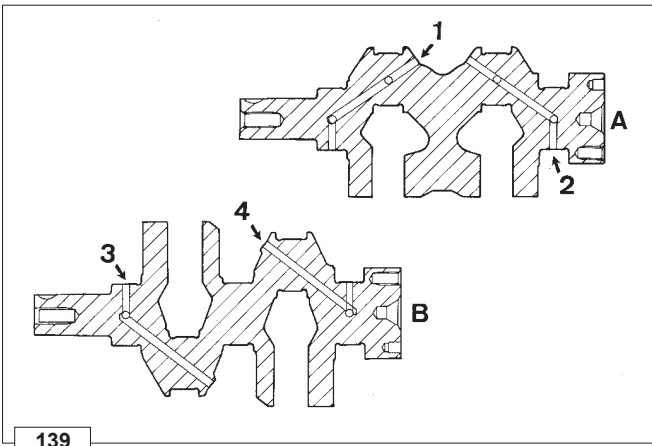

139

Crankshaft, lubrication lines



Caution – Warning

During repairs, when compressed air is used it is important to wear protective goggles.

B = Crankshaft KDW 702

Put the crankshaft in a bath of crude oil. Remove the caps and clean lines 1 and 2 or 3 and 4 with a bit; blow with compressed air. Reposition the new caps in their seating and check the seal.

Engines produced after 2001 do not have plugs for the lubrication ducts.

Simply use a bit and compressed air to clean the ducts.

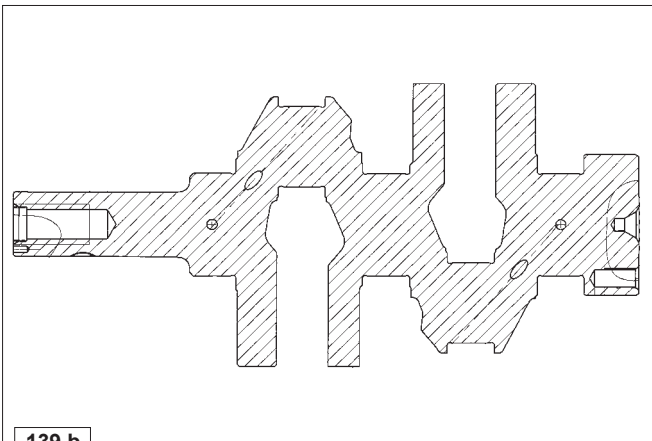

139 b

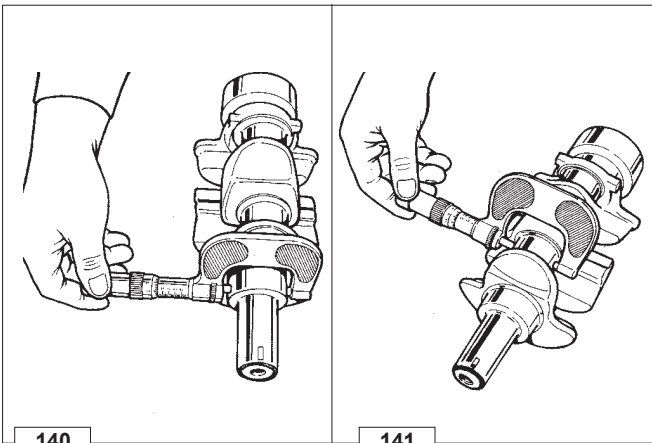

140

141

Crankshaft, check journals and crank

Use a micrometer for the outsides.

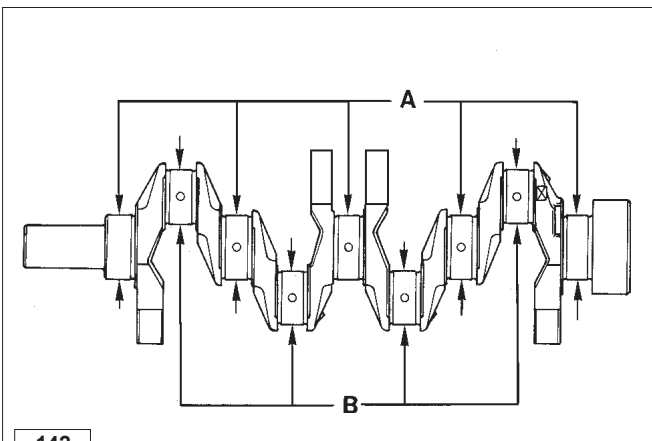

142

Journal and connecting rod pins diameters

Dimensions (mm):

KDW 702-1003-1404		
Ref.	Tolerance	Limit value
A (mm)	50,981÷51,000	50,900
B (mm)	39,394÷40,000	39,900

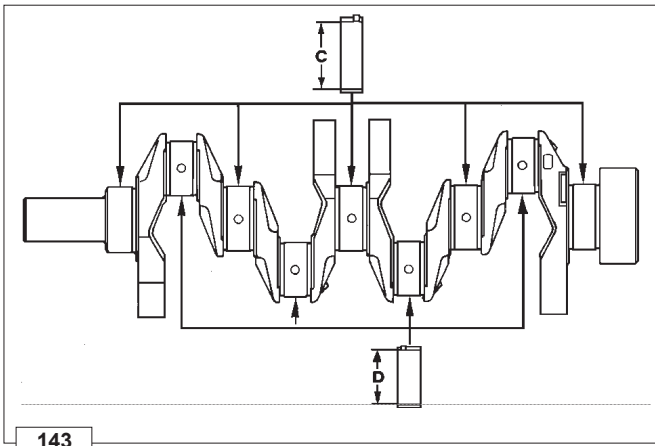

143

Main bearings and connecting rod big ends diameters

Dimensions (mm):

KDW 702-1003-1404		
Ref.	Tolerance	Limit value
C (mm)	51,023÷51,059	51,098
D (mm)	40,021÷40,050	40,100

The dimensions given refer to tightened bearings.

➡ For tightening torque see figures 116 e 126.

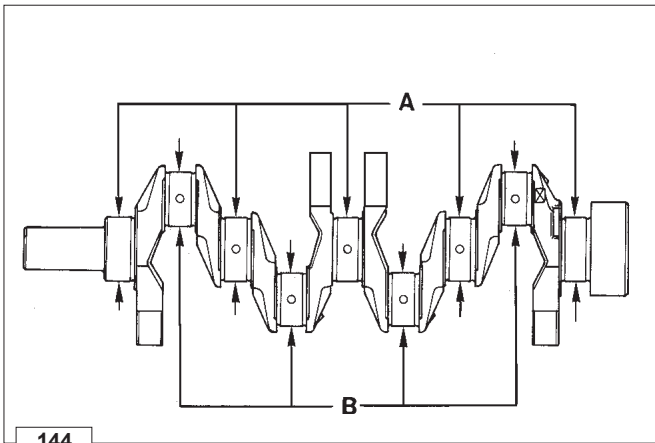

144

Clearances between the bearings and corresponding pins

See figures. 143 ÷ 144.

Dimensions (mm):

KDW 702-1003-1404		
Ref.	Tolerance	Limit value
C-A (mm)	0,023÷0,078	0,200
D-B (mm)	0,021÷0,066	0,130

Nota: Both for crankshaft bearings and for connecting rod big end bearings internal diameter are undersized by 0.25 and 0.50 mm.

TURBO CHARGER

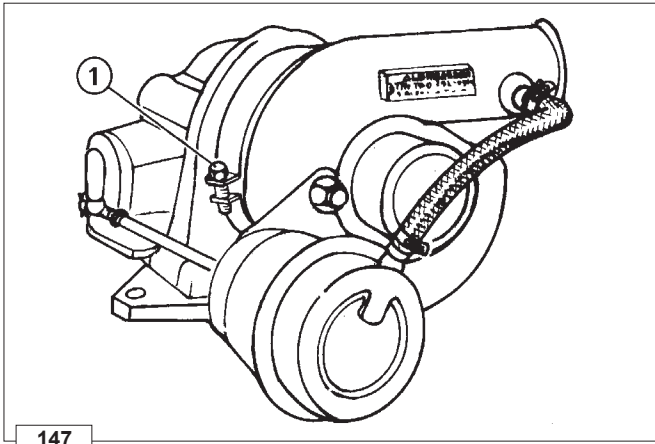

147

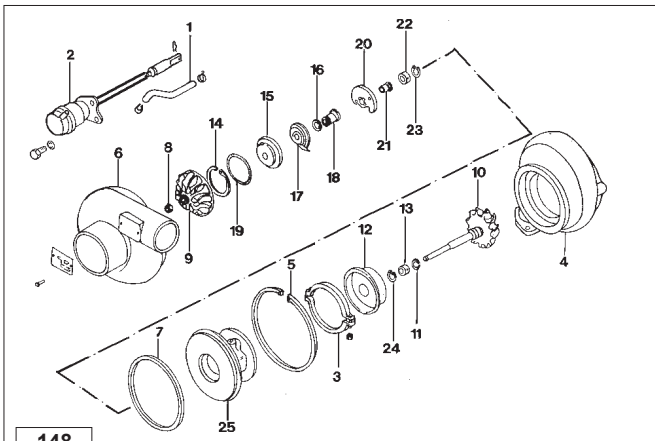

148

Turbocharger components

- 1 Waste gate tube
- 2 Attuatore
- 3 Collare
- 4 Corpo turbina
- 5 Anello seeger
- 6 Chiocciola compressore
- 7 Spessore
- 8 Dado
- 9 Controdado
- 10 Albero con turbina
- 11 Segmento
- 12 Parafiamma
- 13 Cuscinetto
- 14 Seeger
- 15 Spessore
- 16 Segmento
- 17 Deflettore olio
- 18 Manicotto reggispira
- 19 O-ring
- 20 Cuscinetto reggispira
- 21 Anello reggispira
- 22 Cuscinetto
- 23 Anello seeger
- 24 Anello seeger
- 25 Supporto cuscinetti

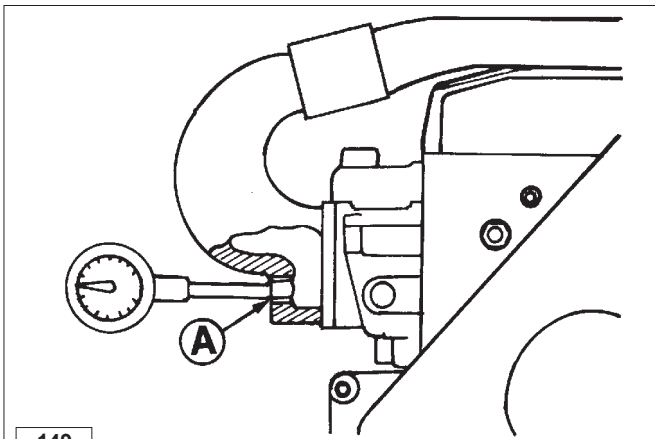

149

Turbocharger pressure testing

Install a 0-2bar pressure gauge at position **A** after removing the existing plug.

Start the engine and operate at low idle for five minutes to allow warm-up.

Increase the engine speed to 3000 r/min or 3600 r/min (depending on engine specification while applying full Nb load to the engine).

➔ See page 10 for the power output curve.

The gauge pressure, at full speed, full load, should be 0.87-0.91 bar (655÷685 mm Hg).

If the pressure setting does not reach specification, adjust the turbocharger waste gate **8** as is defined on page 48.

**Danger – Attention**

- The engine can be damaged if allowed to operate with insufficient oil. It is also dangerous to add too much oil because its combustion may lead to a sharp increase in the rotation speed.
- Use suitable oil in order to protect the engine.
Nothing more than lubrication oil can influence the performances and life of an engine.
- Use of an inferior quality oil or failure to regularly change the oil will increase the risk of piston seizure, will cause the piston rings to jam and will lead to rapid wear on the cylinder liner, the bearings and all other moving parts. Engine life will also be notably reduced.
- The oil viscosity must suit the ambient temperature in which the engine operates.

**Danger – Attention**

- Old engine oil can cause skin cancer if repeatedly left in contact with the skin and for long periods of time. Wear protective gloves to avoid touching used oil.
- If contact with the oil is unavoidable, you are advised to wash your hands with soap and water as soon as possible. Dispose of old oil in the correct way as it is highly polluting.

LUBRIFICATION CIRCUIT

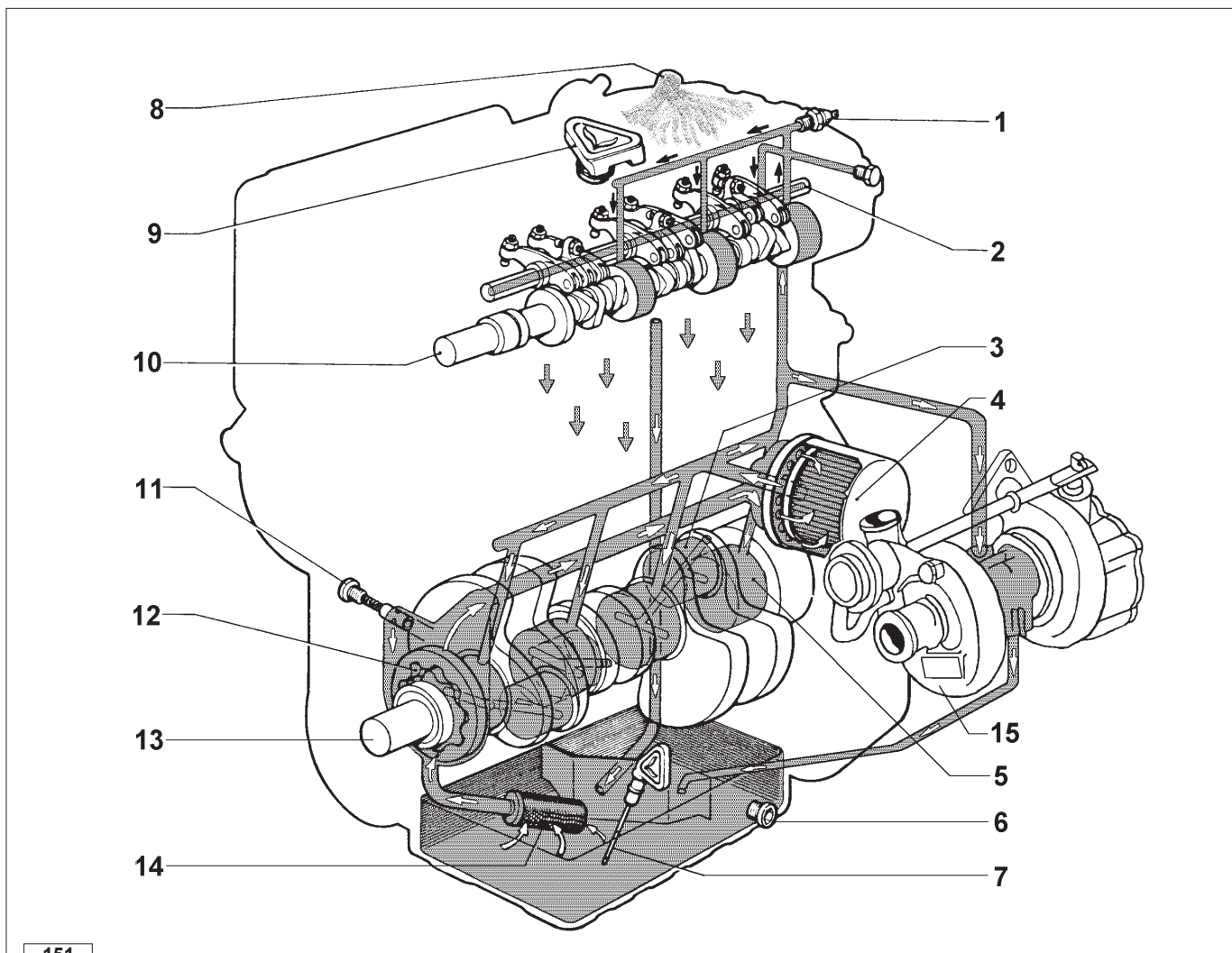

151

Components:

- | | |
|------------------------|----------------------------------|
| 1 Pressure gauge | 9 Oil filler cap |
| 2 Rocker shaft | 10 Camshaft |
| 3 Connecting rod pin | 11 Oil pressure regulating valve |
| 4 Oil filter cartridge | 12 Oil pump |
| 5 Journal | 13 Crankshaft |
| 6 Oil drain plug | 14 Oil suction filter |
| 7 Oil dipstick | |
| 8 Bleed | |

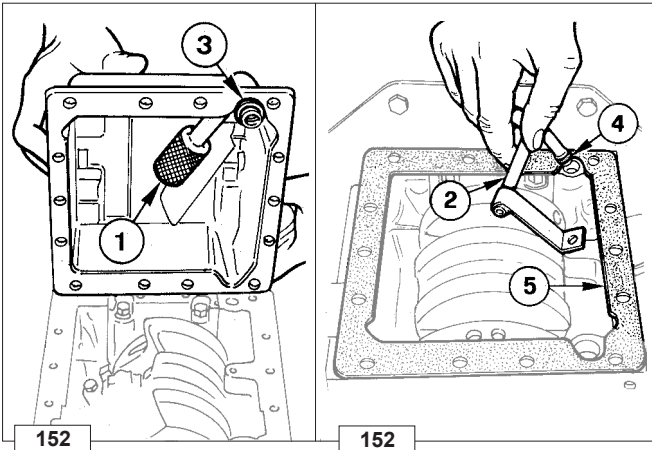

Internal oil filter and oil sump return pipe

Clean with petrol the internal oil filter 1 and oil sump return pipe 2, blow also some compressed air. Replace sealing rings 3 and 4.

- Tighten oil drain plug at a torque of 40 Nm.

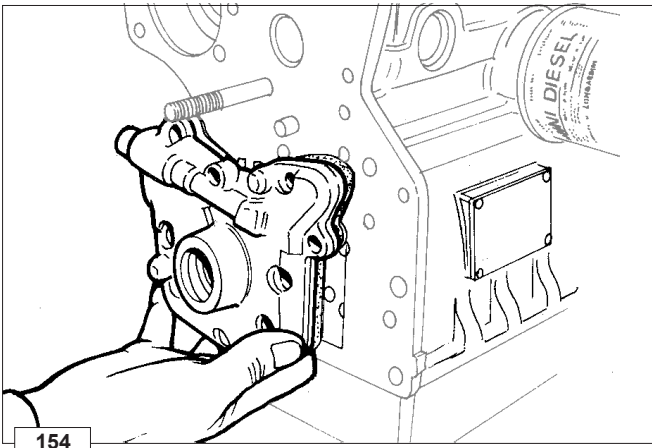

Oil pump

Engine	Delivery (l/1')	Pressure (bar)
702-1003	4÷4,3	3÷3,5
1404	6÷6,5	

Delivery test at 3600 rpm with an oil temperature of 120°C.

Engine	Delivery (l/1')	Pressure (bar)
702-1003	19,3	4÷4,5
1404	28,5	

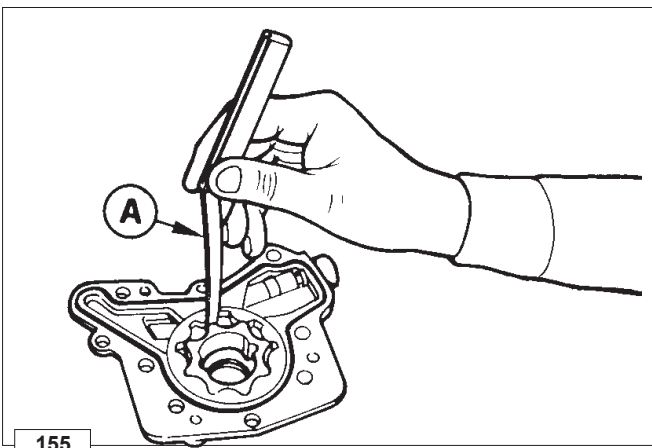

Oil pump, clearance between rotors

Measure the clearance A between teeth as in figure; the maximum value is 0.171 mm. Clearance wear limit should be 0.250 mm.

- ➔ See page 52 for assembly and disassembly.

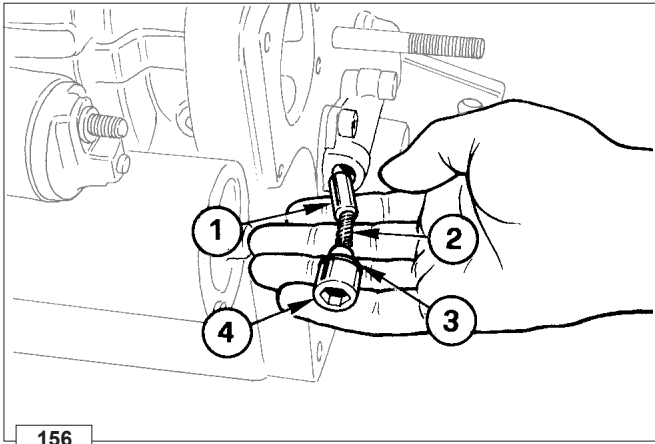

Oil pressure regulating valve

Components:

- 1 Valve
- 2 Spring
- 3 Gasket
- 4 Screw cap

Spring length = 27.50÷27.75 mm

Blow the valve's seating with compressed air and carefully clean all the components before remounting them.

Nota: The valve begins to open at a pressure of 4.5÷5.5 bar.

156

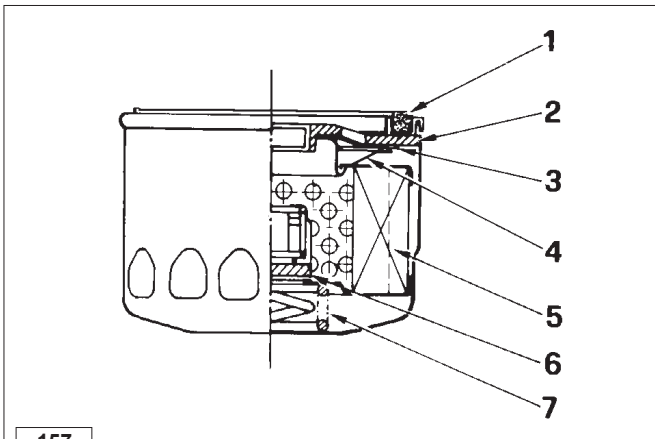

Oil filter cartridge

Components:

- 1 Gasket
- 2 Plate
- 3 Rubber element
- 4 Spring
- 5 Filtering element
- 6 By-pass valve
- 7 Spring

Characteristics:

Maximum operating pressure: 7 bar

Maximum bursting pressure: 20 bar

Degree of filtration: 15 μ

By-pass valve calibration: 1,5÷1,7 bar

Total filtration surface: 730 cm²

157

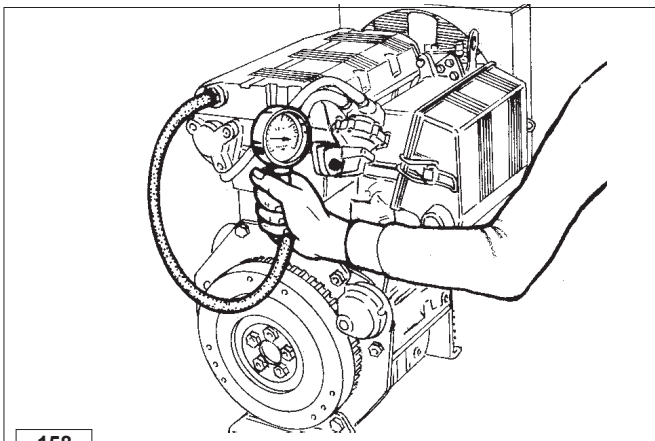

Oil pressure check

! Important

Once remounted fill the engine with oil, fuel and coolant.

Remove the pressure switch, fit a union and connect a 10 bar pressure gauge.

Start the engine and check how pressure is affected by oil temperature.

Nota: With a maximum operating temperature of 120°C at 900 rpm the oil pressure must not be less than 1 bar.

158

! Danger – Attention

- The coolant circuit is pressurised. Do not check it before the engine has cooled down and, also in that case, open the radiator cap or expansion tank plug with caution.
- When there is an electric fan do not approach a hot engine because it could also come on with the engine off.
- The liquid coolant is a pollutant and therefore must be disposed of with care according to environmental provisions.

COOLANT CIRCUIT

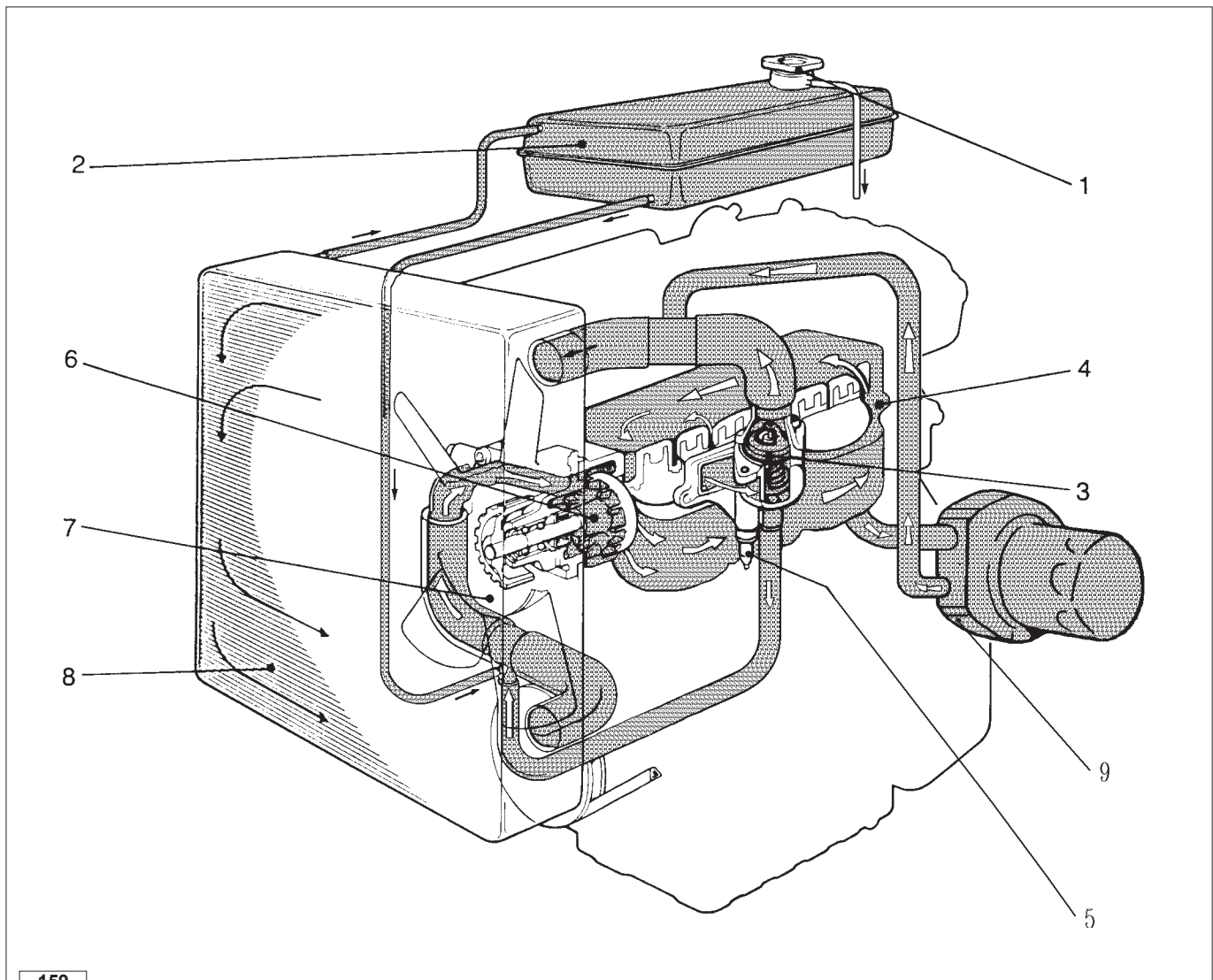

159

Components:

- | | |
|---|--------------------|
| 1 Coolant filler plug | 6 Circulation pump |
| 2 Compensating tank | 7 Fan |
| 3 Thermostatic valve | 8 Radiator |
| 4 Cylinder block | |
| 5 Thermostat for liquid temperature indicator | |

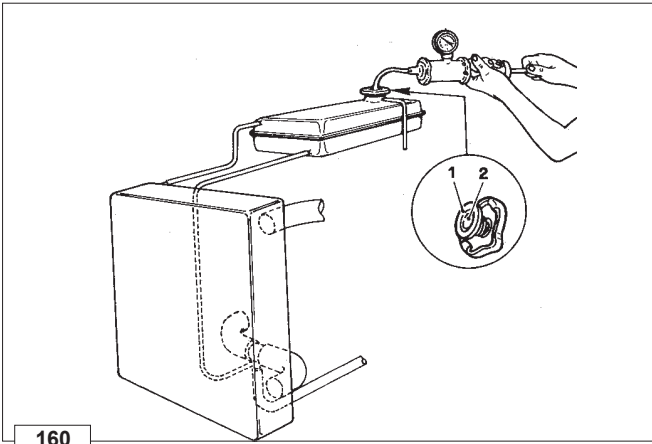

160

Radiator and compensation, check and seal tank cap.

Remove the cap from compensation tank cap and check that the liquid is at the correct level.

Replace the cap with a new one provided with hand air pump socket.

Compress air at a pressure of 1 bar for about two minutes.

Check that there are no drips in the radiator.

The tank cap is supplied with a vacuum relief valve 1 and an overpressure valve 2.

Overpressure valve opening pressure of 0.7 bar.

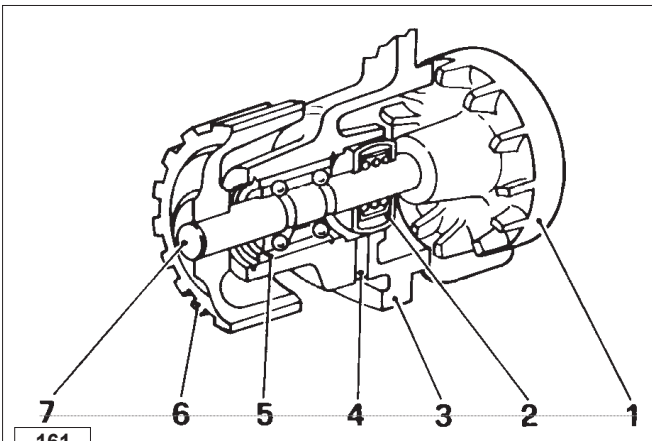

161

Coolant circulation pump, components

- 1 Rotor
- 2 Front seal gasket
- 3 Pump casing
- 4 Exhaust hole
- 5 Bearing
- 6 Pulley
- 7 Shaft

Note: The pump for KDW 1404 engines is different from the one of the other series (fig. 148) due to the presence of a ring between rotor 1 and gasket 2.

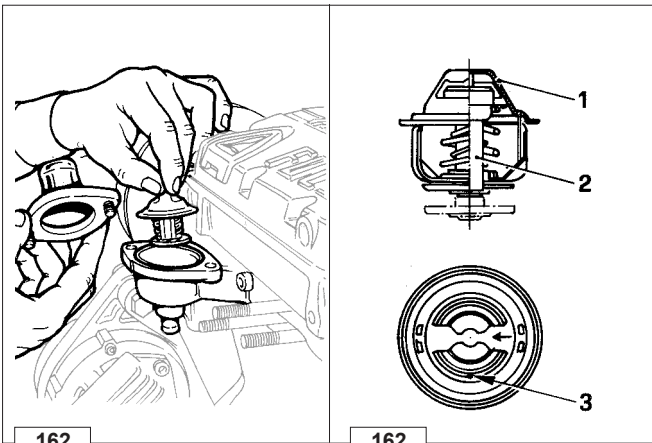

162

162

Thermostatic valve

- 1 - Stainless steel or brass casing
- 2 - Wax bulb
- 3 - Air relief hole

Characteristics:

Opening temperature:..... 83°±87°C

Max stroke at:..... 94°C = 7 mm

Liquid recycling:..... 30÷80 l/h.

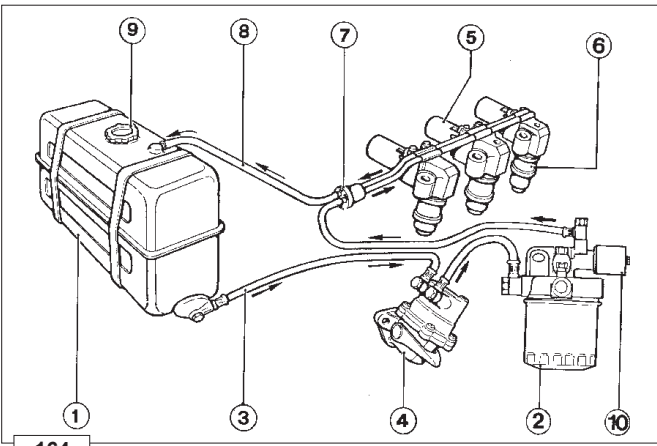

Fuel feeding / injection circuit

Components:

- 1 Fuel Tank
- 2 Fuel filter
- 3 Fuel feeding tube
- 4 Fuel lift pump
- 5 Injection pump
- 6 Injector
- 7 Fuel rail passage rubber joint
- 8 Injector exhaust pipe
- 9 Fuel tank cap
- 10 Solenoid valve

Note: The tank complete with filter is supplied on request.

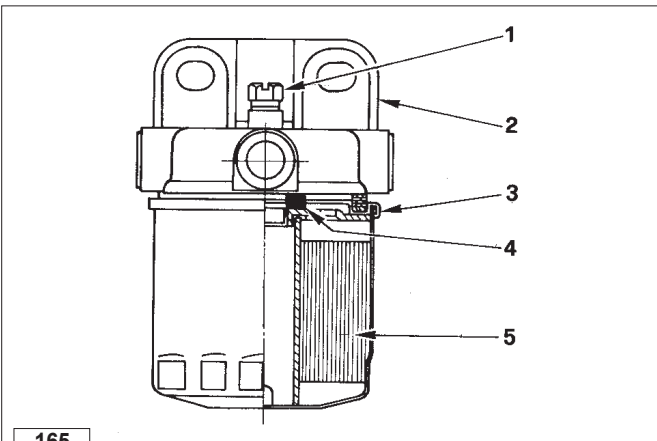

Fuel filter detached from the tank (on request)

- 1 Air relief valve
- 2 Bearing
- 3 Cartridge
- 4 Rubber element
- 5 Filtering element

Cartridge characteristics:

Filtering paper:..... PF 905
 Filtering surface:..... 2400 cm²
 Degree of filtration: 2÷3 μ
 Maximum operating pressure:..... 4 bar

➡ See page 32 for periodic maintenance details.

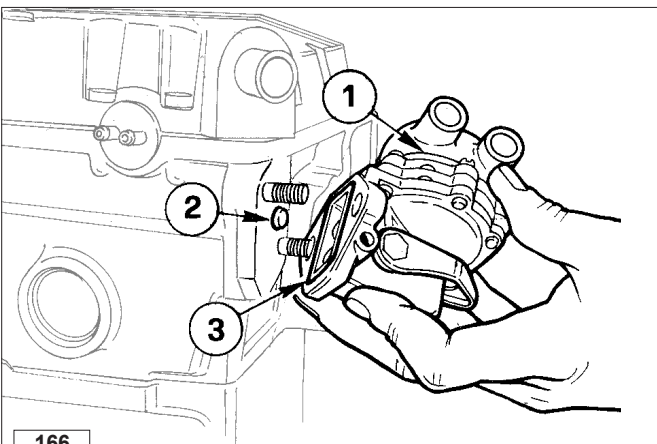

Fuel lift pump

Components:

- 1 Fuel lift pump
- 2 Push rod
- 3 Seal ring

The fuel pump is membrane type. It is driven by camshaft cam via a drive rod.
 It is equipped with an external manual fuel lever.

Characteristics:

With the control cam at 1500 rpm the delivery rate is 75 l/hours and the self-adjusting pressure is at 0.55 to 0.65 bar.

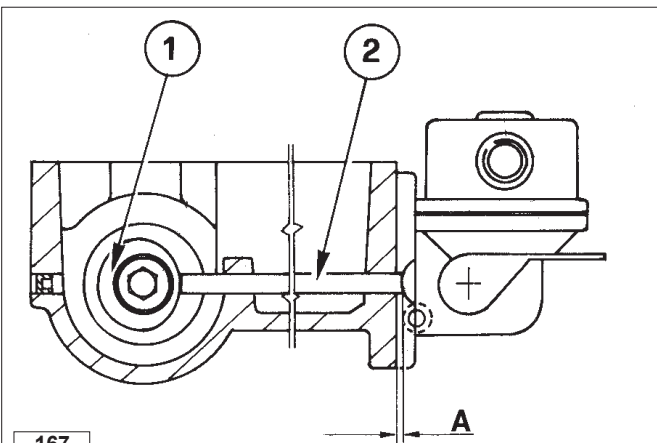

Fuel pump drive rod projection

The protrusion **A** of drive rod **2** from the cylinder head surface is 1.66÷2.18 mm.
 The check must be carried out with cam **1** idle as in the figure.

○ Block the two fuel pump fastening nuts simultaneously at 24 Nm.

Check the length of the drive rod and if it is not the right size, replace it.
 Drive rod length = 153.15÷153.35 mm.

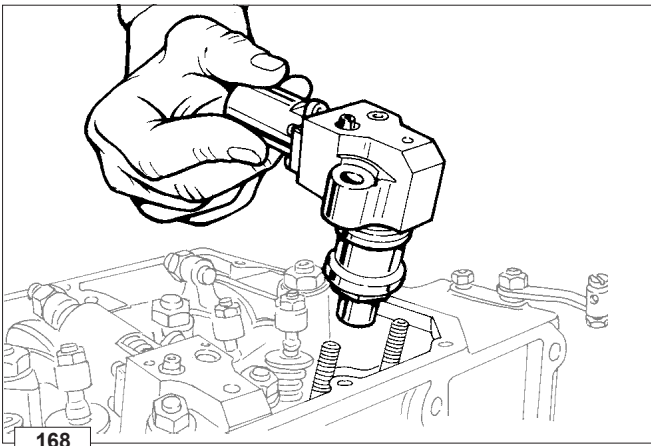

168

Pump/injector unit

Designed by KOHLER, the pump/injector is exclusive to KDW 702-1003-1404 series engines.

The injection system includes two, three, four identical pumps/injector units, each one of which feeds a cylinder.

Note: On pumps/injector units of recent construction (for serial numbers and references see the table on page 88) the pump has been modified (see fig. 174). Following to this modification and others like the elimination of cap **20** of (fig. 169) the method of checking the static injection advance has changed as well, (fig. 187-188) as that of injector setting (fig. 178).

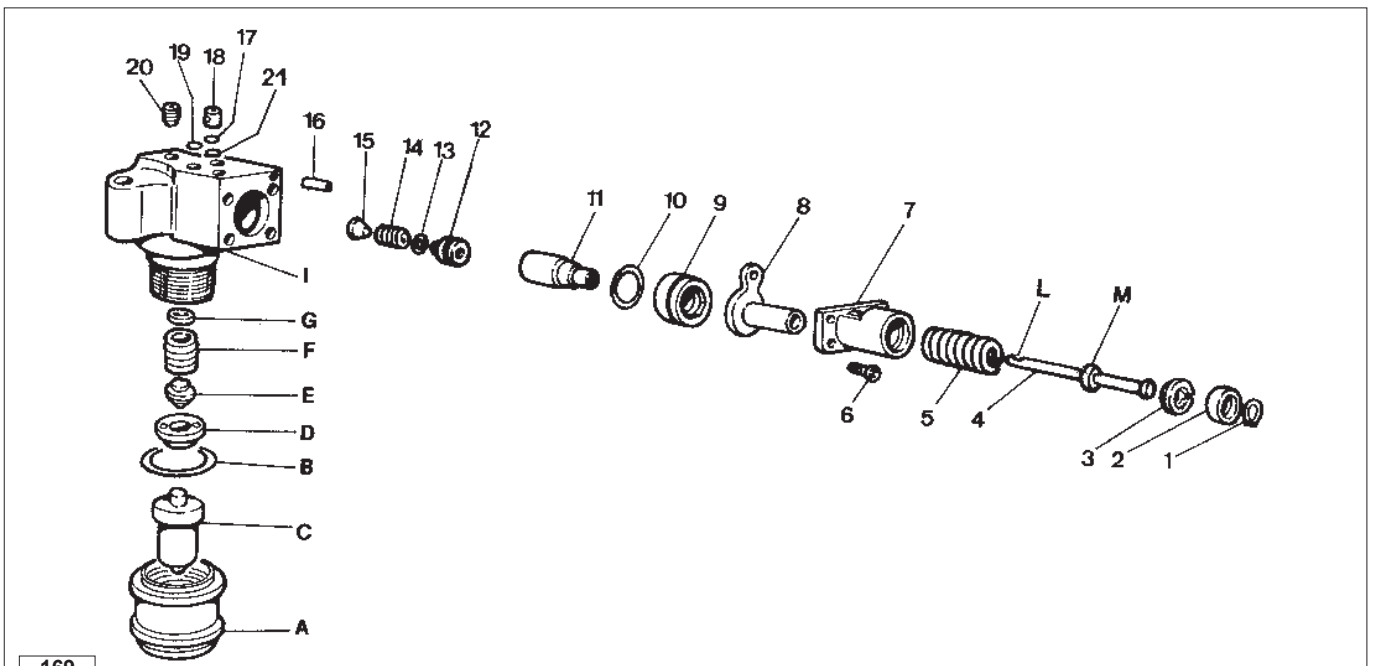

169

Pump/injector unit, components

- | | |
|----------------------------|------------------|
| 1 Seeger ring | A Ring nut |
| 2 Tappet | B O-ring |
| 3 Stop plate | C Nozzle |
| 4 Plunger | D Spacer |
| 5 Spring | E Pressure rod |
| 6 Screw | F Spring |
| 7 Bearing | G Spacer |
| 8 Lever | I Casing |
| 9 Ring nut | L Control spiral |
| 10 Plunger guide O-ring | M Plunger guide |
| 11 Cylinder | |
| 12 Delivery valve | |
| 13 Gasket | |
| 14 Spring | |
| 15 Filler | |
| 16 Pin | |
| 17 O-ring | |
| 18 Non-return valve | |
| 19 O-ring | |
| 20 Cap screw (old type) | |
| 21 Metal gasket (new type) | |

○ When remounting the injector tighten ring nut A at 70 Nm

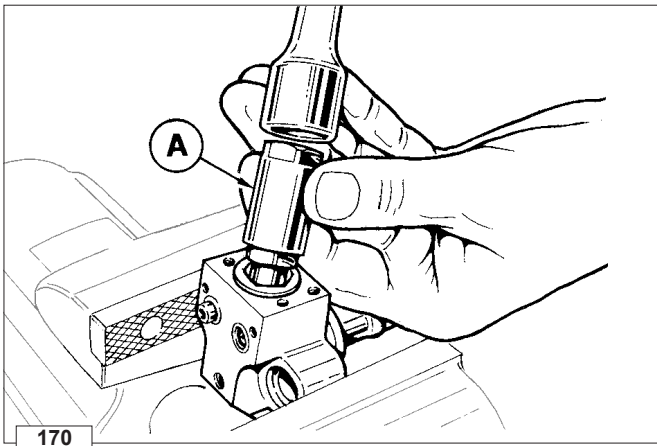

Plunger barrel ring nut assembly/disassembly

To disassemble ring nut (9 fig. 169) use the suitable wrench **A** se.no. 7107-1460-029

- When refitting tighten it a torque of 34 Nm.

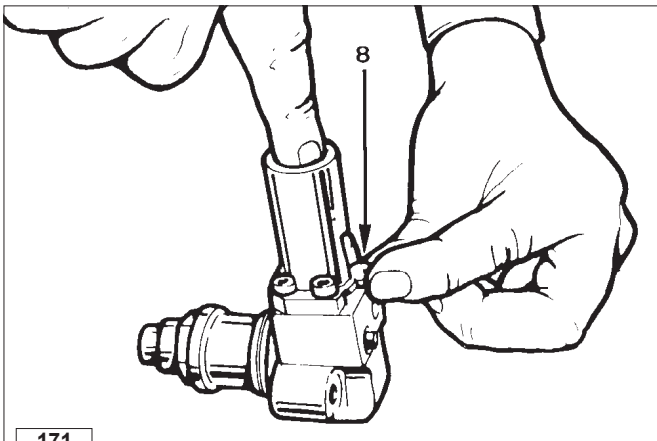

Injection pump assembly/disassembly

Disassemble the unit following the progressive order of fig. 169. Reassemble following the same steps in reverse order. During reassembly, turn the plunger spiral **L** towards the non-return valve **19**, as follows.

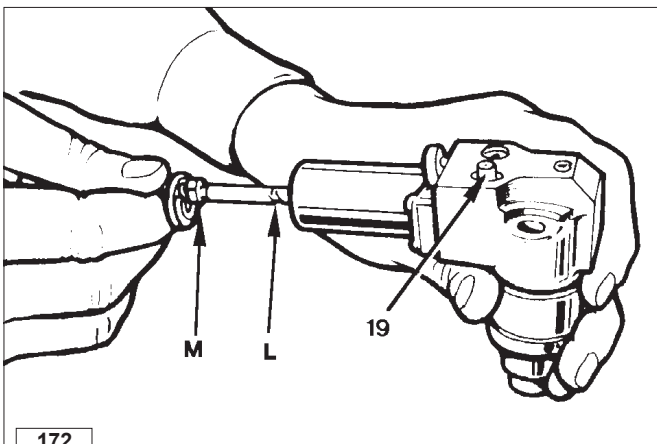

Plunger injection pump reassembly

To be able to insert the plunger in its barrel press with a finger and at the same time slowly rotate lever (**8** fig. 171) until guide **M** of the plunger (fig. 172) enters the lever seating.

Note: If by mistake the plunger is mounted with the spiral in the wrong direction the pump won't function (there is no danger that the engine runs away).

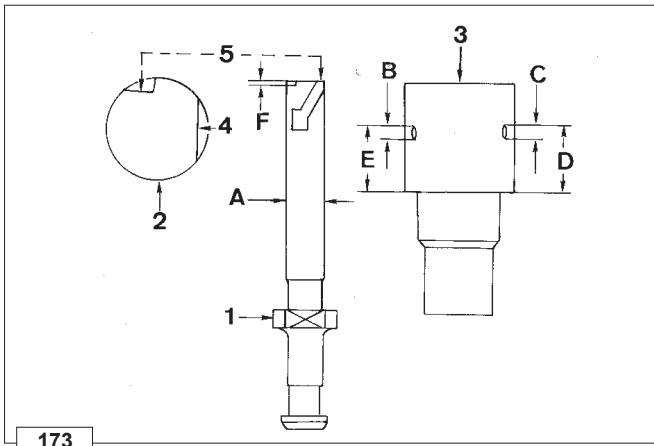

173

Pumping element (old-type injection pump)

- 1 Plunger
- 2 Upper plunger section
- 3 Plunger barrel
- 4 Delay notch
- 5 Control slot

Dimensions (mm):

A	5,5	nominal value
B	2,00÷2,03	inlet hole diameter
C	1,50÷1,53	outlet hole diameter
D	10,00	
E	9,6	
F	0,7	

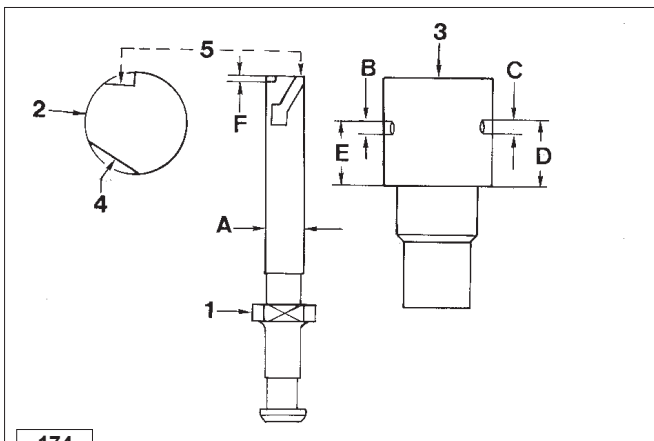

174

Pumping element

- 1 Plunger
- 2 Upper plunger section
- 3 Plunger barrel
- 4 Delay notch
- 5 Control slot

	INJECTION PUMP	Dimensions					
		A	B	C	D	E	F
KDW 702 - 1003 - 1404	6590.290	6,5	1,50 ÷ 1,55	1,50 ÷ 1,53	9,965 ÷ 10,035	9,565 ÷ 9,635	0,9

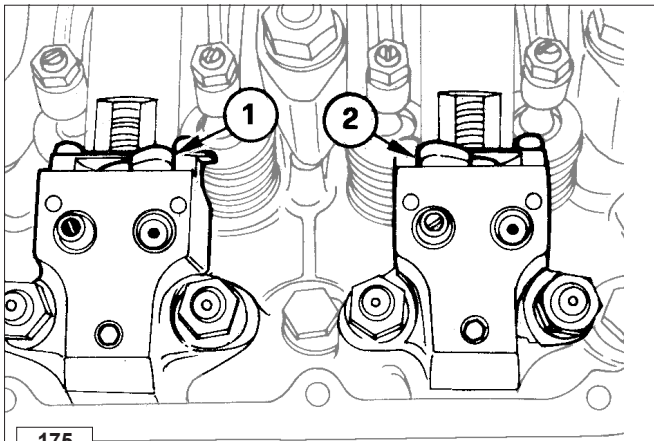

175

Pump/injector unit se.no. 6590.285 control data.

- 1 Delivery control lever on stop position.
- 2 Delivery control lever on maximum delivery position.

Rod stroke form max delivery position (mm)	Rpm (*)	mm ³ /stroke
9,5	3600	19÷23
9,5	1200	15÷24
start position	300	35÷38

Injector setting pressure: 140÷155 bar

* Rpm rating is that of the crankshaft.

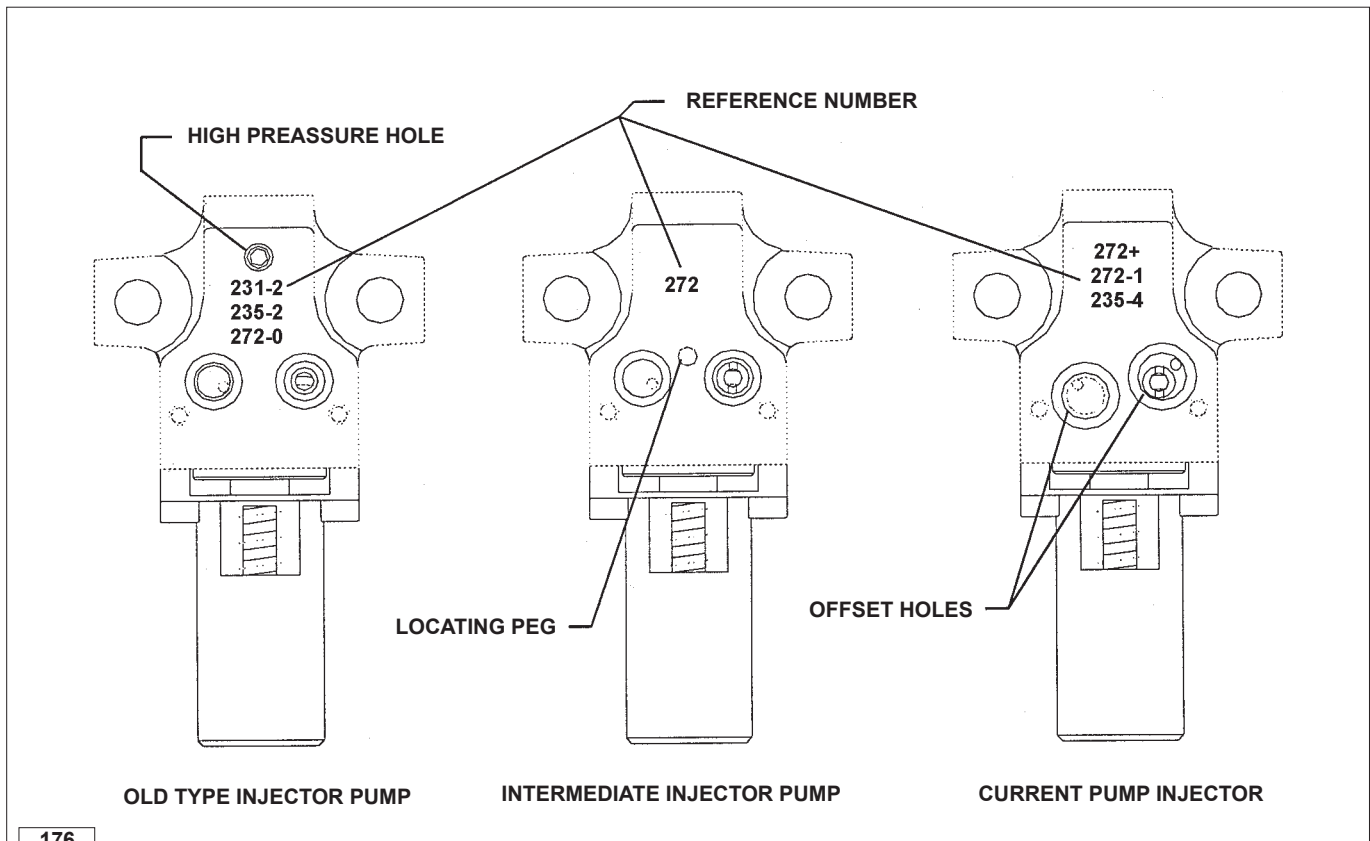

176

KOHLER injection system is being steadily implemented, seeking the best performance of its engines. For this reason the pump injector body has been modified three times in the course of its evolution. Three different pump injectors are shown in the top figure.

- Old type injector pump:** it is characterised by its high pressure hole
- Intermediate injector pump:** is characterised by not having the high pressure hole (the hole can be there but it is only used to control the injector and injection advance) and by the locating peg between inlet and outlet holes.
- Current pump injector:** it is characterised by its offset inlet and outlet holes. These are also oversized, due to the absence of the high pressure hole.

REFERENCE N°	CODE N°	ENGINE TYPE	INJECTION ADVANCE VALUE	SPECIAL TOOLS
235-3 235-4	6590.290	702 - 1003 - 1404	8° ÷ 10° < 2999 g/min 12° ÷ 14° 3000+3600 g/min 13° ÷ 14° > 3600 g/min	ADVANCE / INJECTOR SETTING 1460.074 T.D.C..... 1460.048

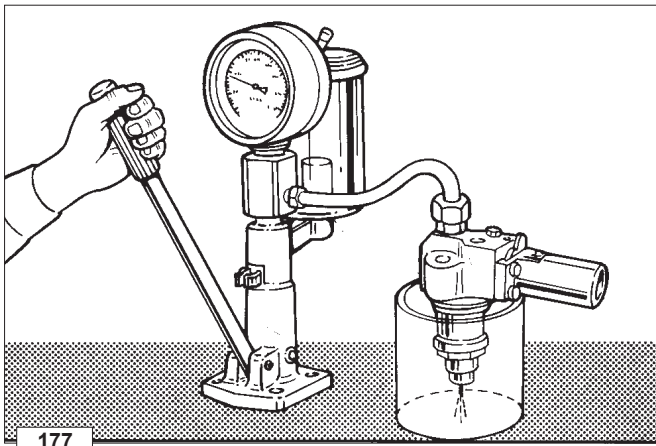

177

Injector, setting (old type)

Connect the injector to a hand pump after removing cap screw (20 fig. 169).

By means of the tool - se.no. 7107-1460-028 - check that the setting pressure is 130÷145 bar.

Adjust, if necessary, by changing the spacer located under the spring.

There are eleven different spare part spacers from 1 to 2 mm.

When you replace the spring, the setting should be made at a pressure higher than 10 bar to compensate for adjustments in operation.

Check the needle seal by slowly actuating the hand pump for 10 seconds, until you reach abt. 130 bar.

If the nozzle drips, replace it.

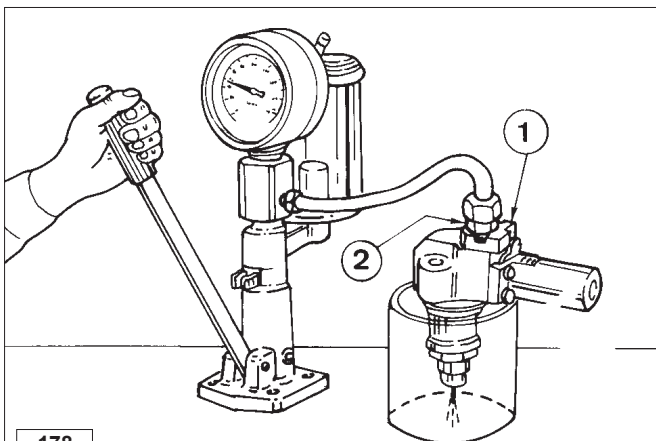

178

Setting of injector according to current pump/injector unit

Remove the non-return valve leaving its metal gasket and fit a cap screw in its place, that is part of tooling 7107-1460-074.

Mount then head 1 and coupling 2.

Then connect a hand pump as shown in the picture.

The pressure setting must be 140÷155 mm bar.

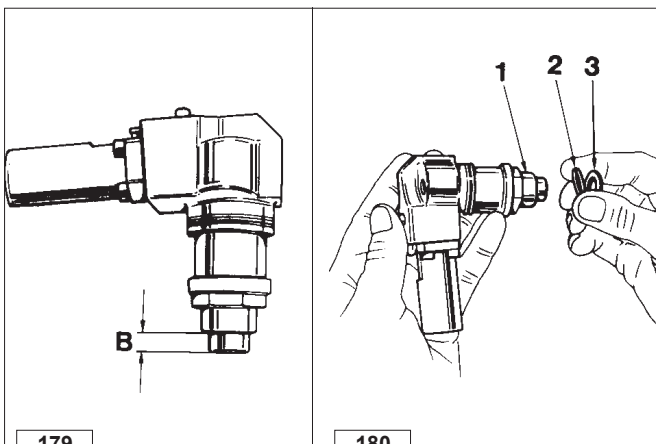

179

180

Injector, nozzle projection

To avoid excessive compression of the spark arrester (A, fig. 181), check projection B of the nozzle (fig. 179).

B = 6.80÷7.05 mm.

If this measure is larger put spacer 2 between ring nut 1 and copper gasket 3.

0.25 mm thick spacers are available.

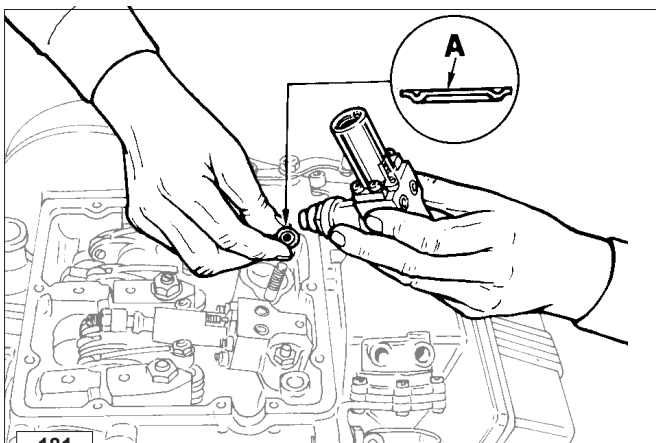

181

Injector, spark arrester

Important

Every time you remove the pump/injector you must replace the spark arrester, the copper gasket, the oil O-ring, as well as the 2 fuel O-rings.

Insert the spark arrester in the injector housing with surface A pointing upwards.

○ Tighten simultaneously both nuts that fasten it to the head at 20 Nm.

For engines with the injectors fixed with self-locking nuts, tighten the nuts at 23 Nm.

➔ See page 32 for periodic maintenance details.

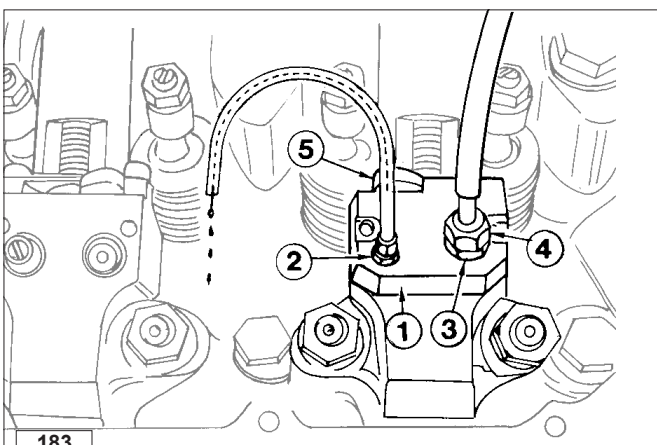
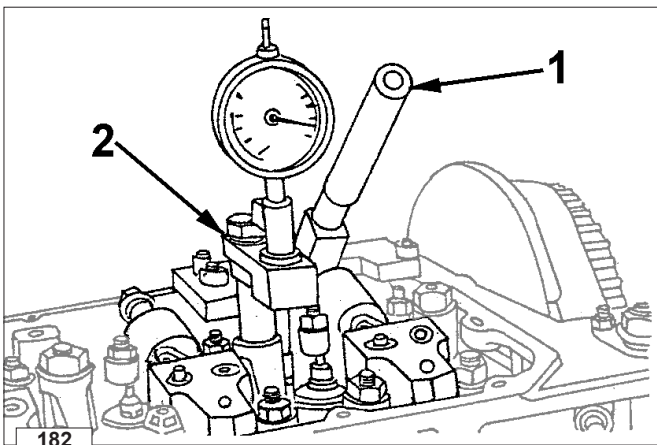

Injection advance control and regulation

- Dismount the rocker arm cover (see page 52).
 - Position the device on the head, in contact with cylinder no. 1.
 - Mount the dial gauge on the valve controlled by tool ref. 1460.048.
 - Via lever **1** of the tool, open the valve until it comes into contact with the piston.
 - Then rotate the crankshaft until the TDC is read in the dial gauge. Then reset the hundredths.
 - Remove the fuel pipes.
 - Remove the O-ring in contact with the non-return valve and replace it with the appropriate gasket - equipment component part ref. 1460.074. Once the check has been completed, remove the gasket and refit the O-ring.
- Connect tool 1460.074 on pump n° 1. This will automatically position the control lever to the maximum delivery. The tool is provided with **3+4** couplings for connection to a tank that must be not lower than 30 cm from the pumps level. Coupling **2** is equipped with a plastic pipe **5** with internal drip collecting wire.
- Put cylinder **1** under compression and open the tank tap. Fuel diesel will start to flow out from coupling **2**.
 - Slowly rotate the engine towards TDC 1 until the diesel fuel stops leaking out.
 - At this point with lever **1** (of fig. 182) move again the valve until it touches the piston and read on the dial gauge how many hundredths are missing from the previously reset value (TDC).
 - To convert hundredths into degrees, consult the table below.
 - Repeat the operation on the other cylinders.

α	KDW 702-1003-1404 mm
18°	2.468
17°	2.205
16°	1.956
15°	1.721
14°	1.501
13°	1.296
12°	1.105
11°	0.930
10°	0.769
9°	0.623
8°	0.793
7°	0.378
6°	0.277

Injection advance for currently used pump/injector unit

Engine	Code	Reference n°	Rpm	α
702-1003 1404	6590.290	235-4	1500÷2999	8°÷10°
702-1003 1404	6590.290	235-4	3000÷3600	12°÷14°
702-1003 1404	6590.290	235-4	> +3600	13°÷15°

* With aluminum crankcase

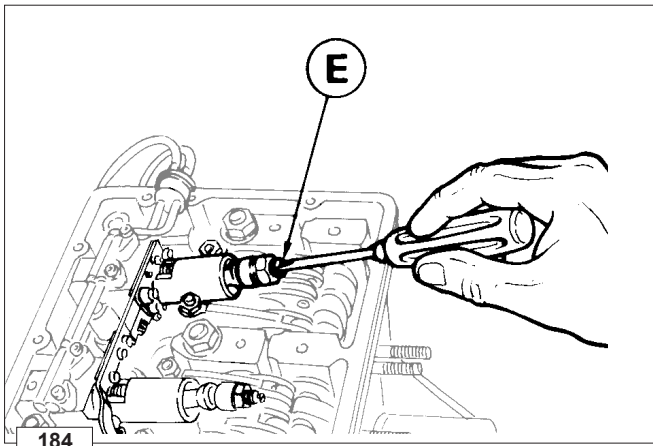

184

Static injection advance tuning

If the injection advance value found does not correspond to the previously described value, adjust the screw **E** and repeat the test.

Rotating screw **E** by ½ turn will change the injection advance by 5°. If turned clockwise, injection is advanced.

In the opposite direction, injection is delayed.

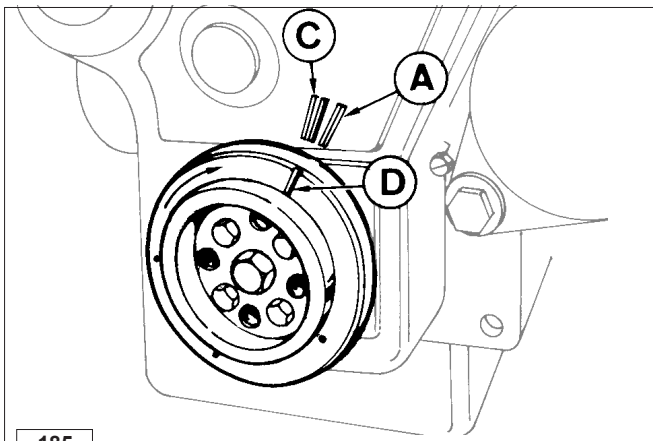

185

Injection advance references on timing belt protector

The method of checking injection advance is essentially the same as that described in fig. 182 with one difference: instead of using the device se.no. 7107-1460-048 with which you measure piston lowering with respect to the Top Dead Centre, you use references **A** and **C** on the timing belt protector and reference **D** located on engine pulley.

When **D** coincides with **A** the piston has reached its TDC.

When **D** coincides with **C** the piston is in injection advance position.

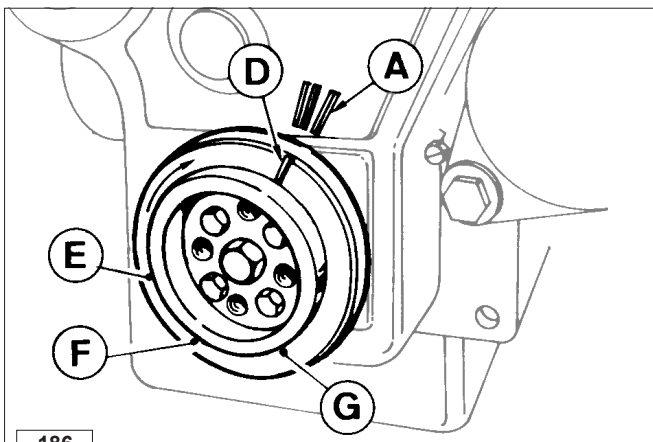

186

TDC (Top Dead Center) references

D coincides with **A** = TDC of 1st cylinder of all series engines, of 4th cylinder KDW1404.

E coincides with **A** = TDC of the 2nd cylinder KDW 1003.

F coincides with **A** = TDC of 2nd cylinder KDW 702, of 3rd and 2nd cylinder KDW 1404.

G coincides with **A** = TDC of 3rd cylinder KDW 1003.

Note: Following the arrow's rotation direction, the combustion order for KDW 1003 is **D, G, E** (1st - 3rd - 2nd cylinder respectively). As to KDW 1404 the sequence is **D, F, D, F** (1st- 3rd- 4th and 2nd cylinder).

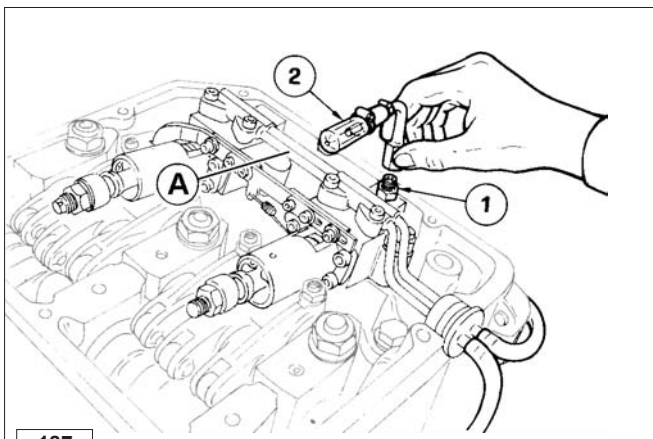

187

Tester and special coupling for injection advance control (Old-type injection pump)

1 Special coupling. Serial number: 7107-1460-028

2 Injection advance tester. Serial number: 7271-1460-024.

Remove the cap on the pump/injector casing and in its place screw on coupling **1**.

On this coupling tighten the tester **2**.

Note: When reassembling the cap on the pump/injector unit, check its seal.

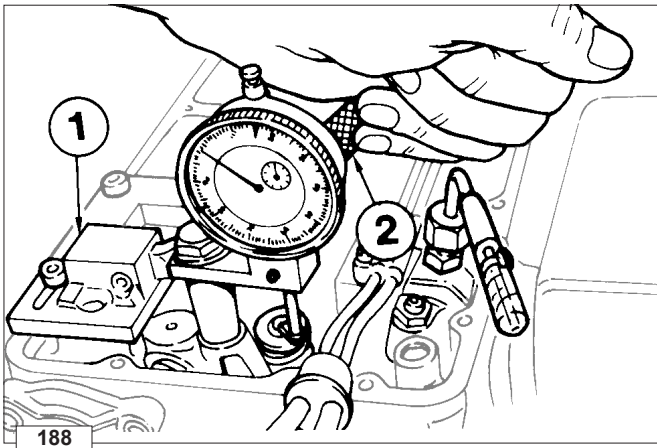

Static injection advance regulation

Fill the tank and operate the fuel pump.
 Set the pump/injector delivery control rod (ref. **A** fig. 187) at half-stroke.
 Bring the piston to the top dead centre of compression. Fit a 13 mm hexagon wrench on the injection advance adjusting screw lock nut. By turning the wrench forth and back you prime the injection pump, thus enabling the tester to be drained.
 With the piston at its TDC, operate lever **2** (fig. 188) and bring the drain valve into contact with the piston. Then reset dial gauge.
 Go back ¼ of a turn moving the crankshaft anticlockwise. Then turn forward again very slowly observing the fuel level inside the tester. As soon as the level changes, then stop. You reached the static injection advance.
 By actuating lever **2** check piston lowering with respect to the TDC.
 The table on page 90 shows both piston lowering expressed in mm, with respect to the TDC, and the corresponding rotation of the crankshaft, expressed in degrees.
 The static injection advance in degrees $\alpha = 11^\circ$ to 13° refers to all engines for adjustments from 1500 / 3600 rpm.

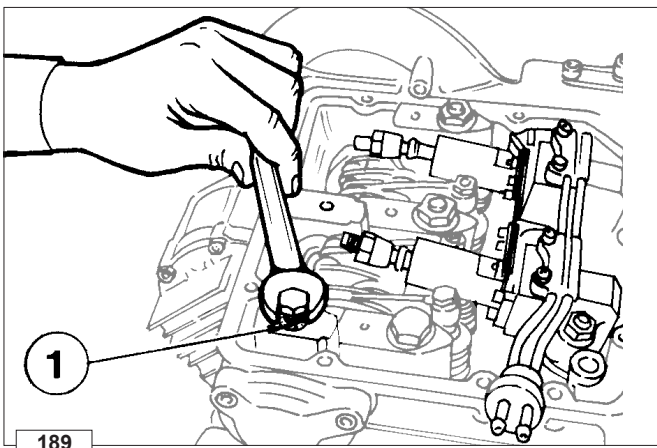

Preliminary steps to pump/injector unit delivery balancing test

Closing the oilhole

To perform this test you must remove the rocker arms cover and close hole **1** with an M 8x1.25 or M 10x1.5 screw (on latest model engines) not longer than 8 mm. Also remove the copper gasket.
 If the camshaft and rocker arms are dry, lubricate them with engine oil.

Note: If you only want to check the nozzle it is not necessary to balance the deliveries; provided that when you dismount the rod you do not loosen adjusting screws (**1** and **2**, fig. 193).

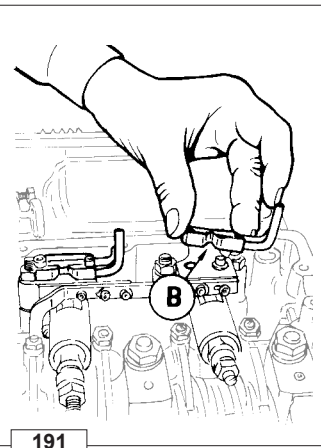
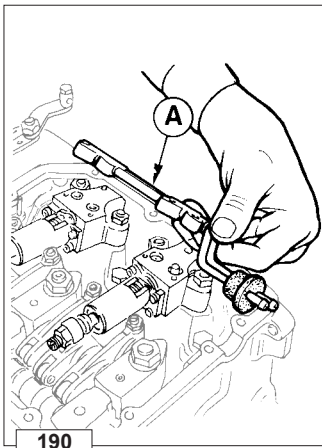

Test head B assembly

Remove fuel pipe **A** and mount one test head **B** in its place per pump/injector.
 The test heads complete with pipes are supplied together with instrument ref. 7104-1460-069.

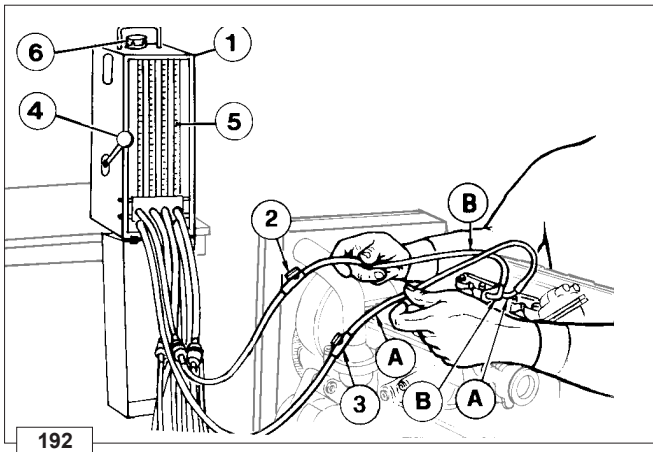

Instrument connection

Place the instrument **1**, se.no. 7104-1460-127 at least 20 cm above the pump/injector level.

Connect pipe **A** (outlet from every instrument test piece) with pipe **A** (inlet of every pump/injector) and pipe **B** (return to the instrument) with pipe **B** (outlet from the pump/injector).

Open tap **2** and **3** of each pipe and fill the instrument with diesel. Start the engine and bring it to 1500 rpm idle running.

Close the fuel supply to the engine from the instrument's tank using lever **4** and after 1 minute observe the levels in the test piece.

If a level goes down more than the others it is necessary to decrease the delivery of the corresponding pump (see below) and vice versa to increase the delivery if the level increases.

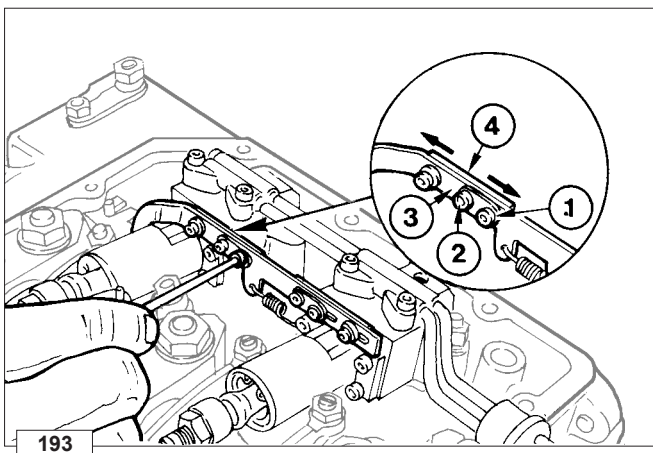

Injection pumps delivery balancing

In case the balancing error read on the test pieces is greater than 2 cm³/min, then injection pumps deliveries should be adjusted.

Plate **4** and rod **3** are blocked by screws **1** and **2**. Loosen them. Move plate **4** rightwards with respect to rod **3** if you want to increase delivery.

If moved leftwards delivery decreases. Make very small movements with the plate.

- Tighten screws **1** and **2** at a torque of 1,1 Nm.



Important

Each time a pump/injector is replaced it is necessary to balance the deliveries.

**ELECTRIC CONTROL PANEL WITH AUTOMATIC ENGINE STOP
(UPON REQUEST)**

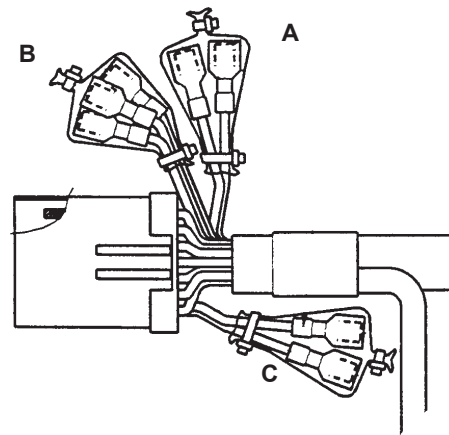
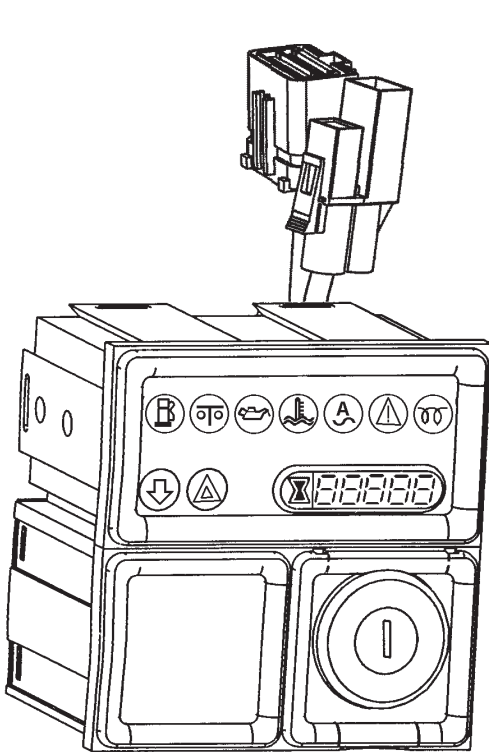
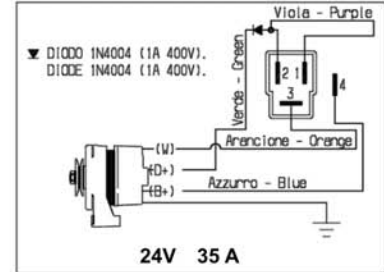
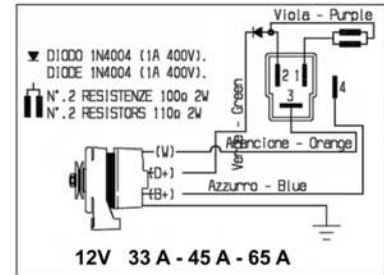
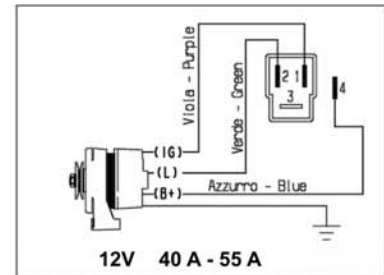
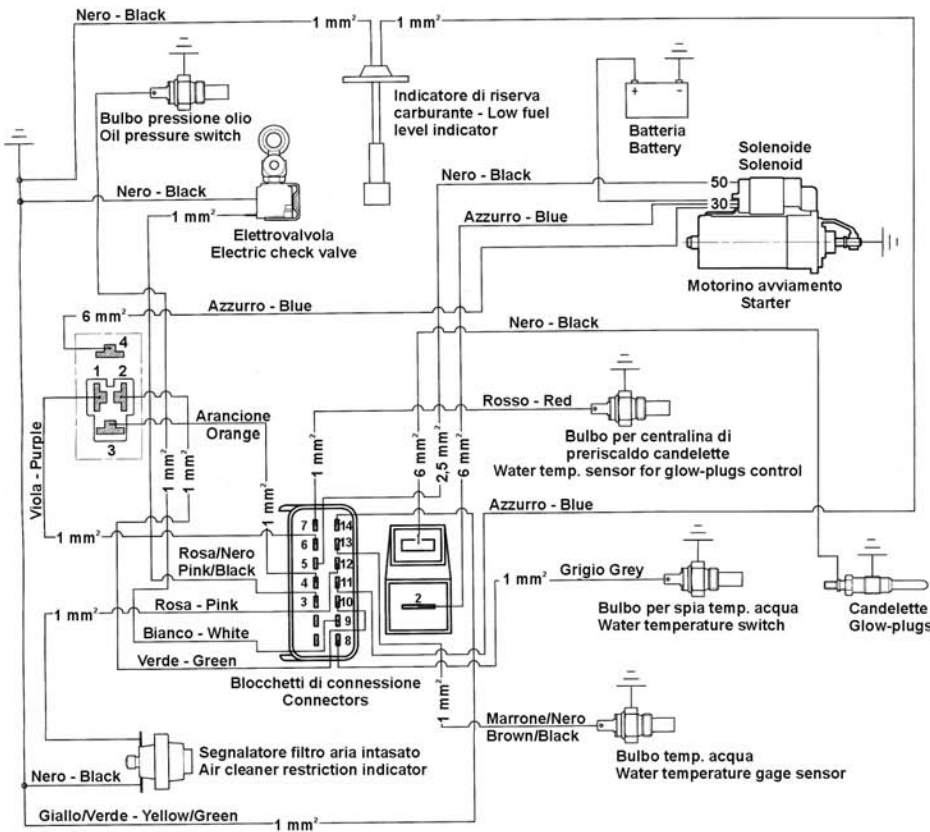

AUXILIARY TERMINALS	
A	Brown-black = Signal for H2O temperature instrument (6.3)
	Orange = Signal for electric rev. indicator (6.3)
B	White = Oil pressure ON/OFF signal (6.3)
	Purple = (+) Positive under key (6.3)
	Yellow-green = (-) Negative - Earth (6.3)
C	Yellow = Protected socket available for engine stop in an emergency (6.3)
	White-blue = Socket available for emergency indicator light (6.3)

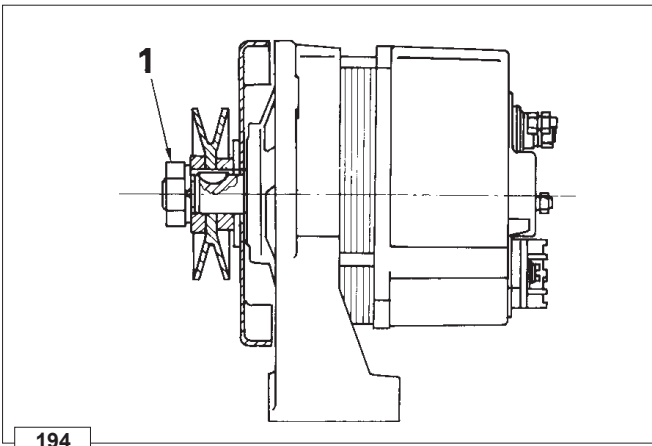

Alternator, 14V 33A

Nominal voltage..... 14V
 Nominal current output 33A
 Maximum Rpm 12.000 giri/1'
 Maximum peak Rpm..... 13.000 giri/1'
 Voltage regulator AER 1503
 Rotation (viewed at pulley end): Clockwise

○ Tighten nut 1 at a torque of 35+45 Nm.

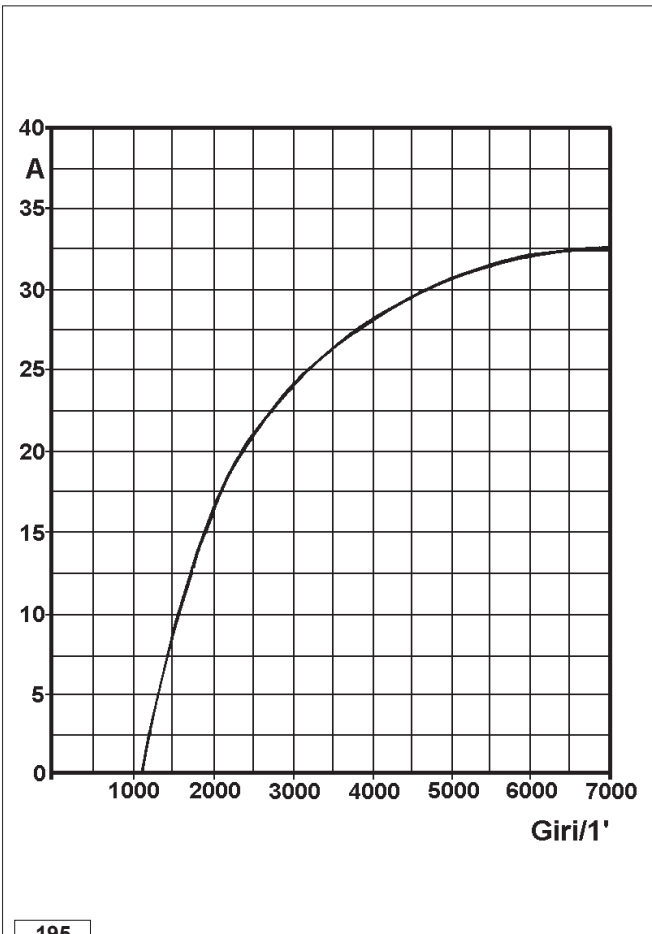

Alternator, 14V 33A - Performance Curve

The curve was obtained at room temperature of +25°C with 13 V battery voltage.

Note: The rpm shown on the table are referred to the alternator.
 Engine rpm/alternator rpm ratio, with driving pulley diameter:
 85 mm = 1:1,23
 105 mm = 1:1,52
 112 mm = 1:1,62.

Electric starting layout (12V) with alternator 14V 33A

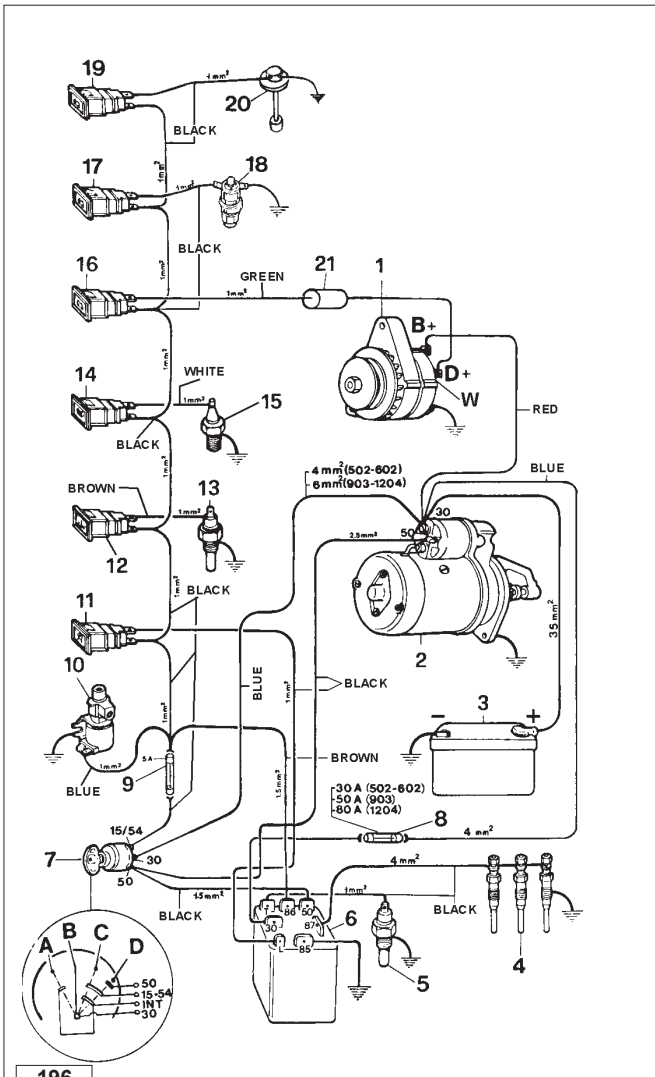

- 1 Alternator
 - 2 Starter Motor
 - 3 Battery
 - 4 Glow Plugs
 - 5 Coolant temperature thermistor
 - 6 Glow Plug Controller / Timer
 - 7 Key Switch
 - 8 System Fuse, 30A for KDW 702; 50 A for KDW 1003; 80 A for KDW 1404.
 - 9 Fuse (Accessory)- 5A
 - 10 Fuel Solenoid Valve
 - 11 Glow Plug Indicator Lamp
 - 12 Coolant High Temperature Lamp
 - 13 Coolant High Temperature Switch
 - 14 Oil Pressure (Low) Lamp
 - 15 Oil Pressure Switch
 - 16 Alternator Charging Lamp
 - 17 Air Filter High Restriction Indicator Lamp
 - 18 Air Filter Restriction Switch
 - 19 Low Fuel Level Lamp
 - 20 Low Fuel Level Switch
 - 21 Diode
- A Accessory Position
 B Off Position
 C On Position
 D Starting Position

Note: Battery 3 not supplied by KOHLER.
 For assembly we recommend a battery with the following characteristics, see table below.

Engine type	Starter motor class (epicyclic type) Kw	Normal starting conditions		Heavy-duty starting conditions (max allowed)	
		Capacity K20 - Ah	Rapid discharge intensity (DIN Standards at -18° C) A	Capacity K20 - Ah	Rapid discharge intensity (DIN Standards at -18° C) A
702	1,6	66	300	88	330
1003	1,6	66	310	88	330
1404	1,6	66	300	88	330

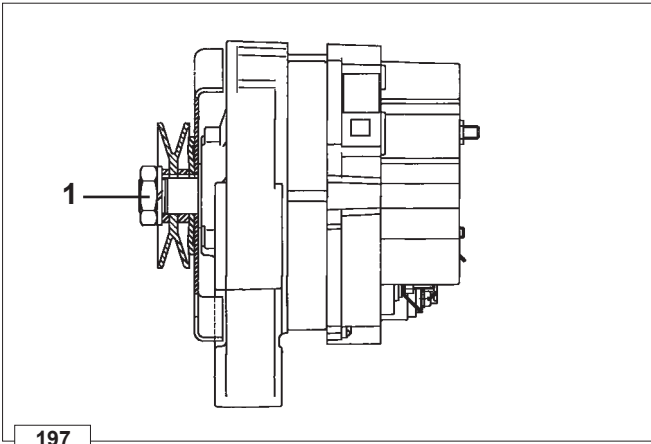

197

Alternator 14V 45A - 65A

Characteristics:

- Nominal voltage = 14V
- Nominal current output = 45A - 65A
- Maximum Rpm = 14000 giri/1'
- Maximum peak Rpm (for 15') = 15000 giri/1'
- Bearing, Pulley End = 6203-2Z
- Bearing, Voltage Regulator End = 6201-2Z/C3
- Voltage regulator = RTT 119 A
- Rotation (viewed at pulley end): Clockwise

Note: Use only high temperature grease when servicing bearings

○ Tighten nut 1 at a torque of 60 Nm.

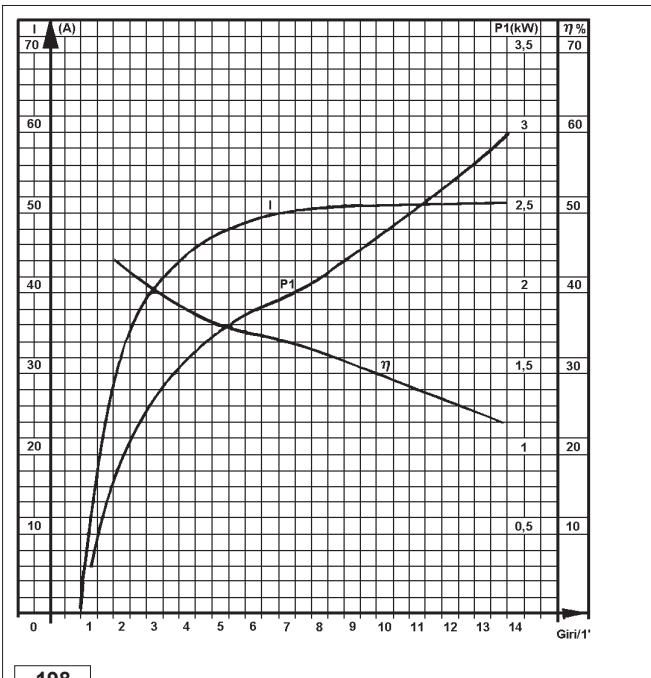

198

Alternator, 14V 45A - Performance Curve

The curve was obtained at room temperature of +25°C with a constant 13 V battery voltage.

- P1 = Power Output (KW)
- I = Current Output (Amps)
- η = Efficiency

Note: The RPM shown is that of the alternator. The value of the rpm axis must be multiplied by 1000.

Alternator speed is a function of engine speed and the crankshaft pulley diameter. If the engine pulley diameter is :

- 85 mm = 1:1,3
- 105 mm = 1:1,6
- 112 mm = 1:1,72.

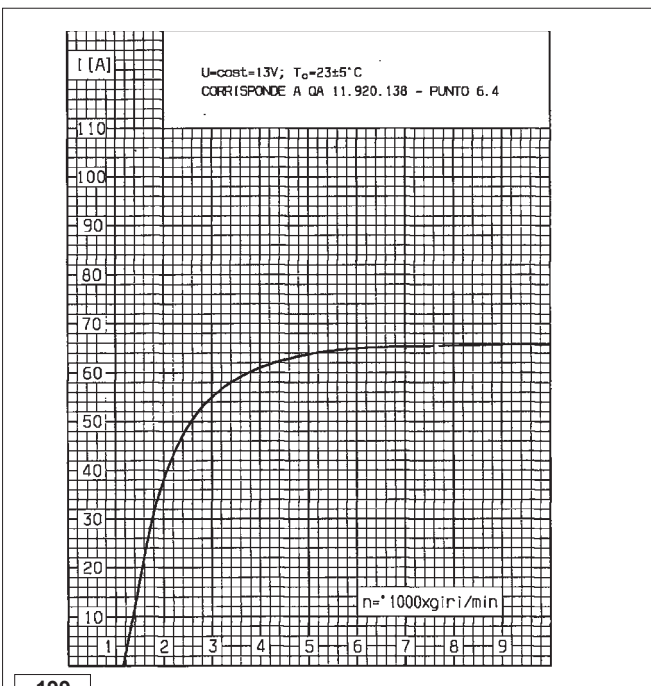

199

Alternator, 14V 65A - Performance Curve

The curve was obtained at room temperature of +25°C with a constant 13 V battery voltage.

- P1 = Power Output (KW)
- I = Current Output (Amps)
- η = Efficiency

Note: The RPM shown is that of the alternator. The value of the rpm axis must be multiplied by 1000.

Alternator speed is a function of engine speed and the crankshaft pulley diameter. If the engine pulley diameter is :

- 85 mm = 1:1,3
- 105 mm = 1:1,6
- 112 mm = 1:1,72.

Electric starting layout 12V 33A - 45A - 65A

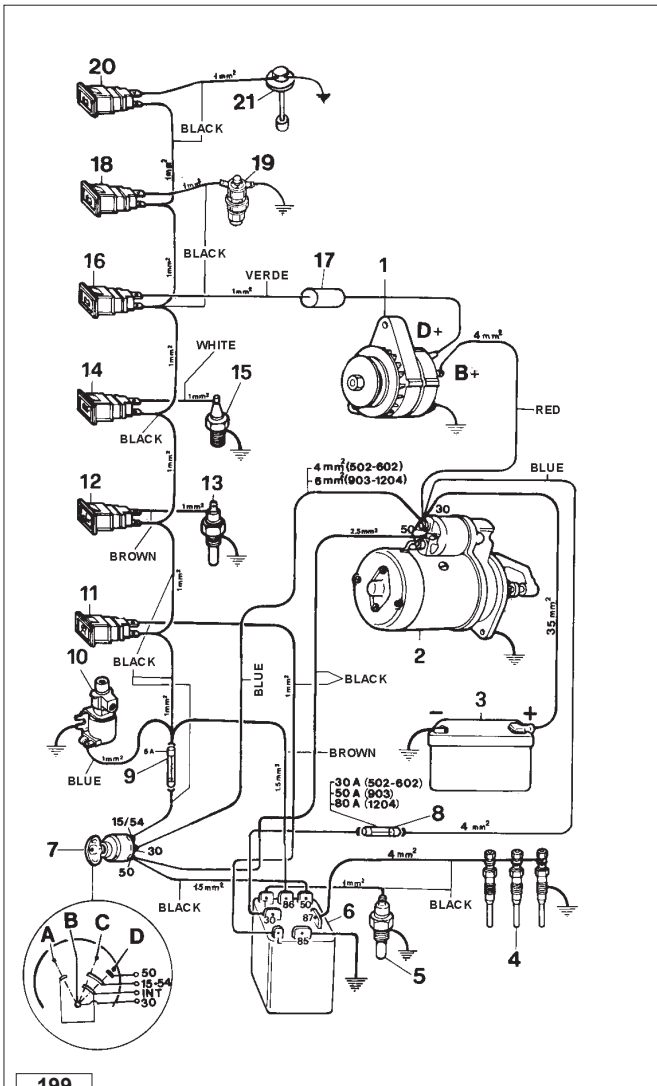

- 1 Alternator
- 2 Starter Motor
- 3 Battery
- 4 Glow Plugs
- 5 Coolant temperature thermistor
- 6 Glow Plug Controller / Timer
- 7 Key Switch
- 8 System Fuse: 30A for KDW 702;
50A for KDW 1003;
80A for KDW 1404.

- 9 Fuse (Accessory)- 5A
- 10 Fuel Solenoid Valve
- 11 Glow Plug Indicator Lamp
- 12 Coolant High Temperature Lamp
- 14 Oil Pressure (Low) Lamp
- 15 Oil Pressure Switch
- 16 Alternator Charging Lamp
- 17 Diode
- 18 Air Filter Restriction Switch
- 19 Air Filter Restriction Switch
- 20 Low Fuel Level Lamp
- 21 Low Fuel Level Switch

- A Accessory Position
- B Off Position
- C On Position
- D Starting Position

Note: Battery 3 not supplied by KOHLER, for battery characteristics see page 96.

Flywheel Alternator

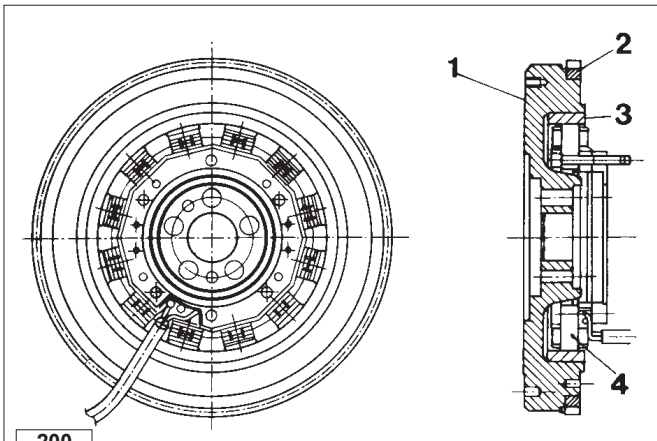

12V 30A with two cables at output

- 1 Flywheel
- 2 Ring gear
- 3 Magnet ring (Rotor)
- 4 Stator

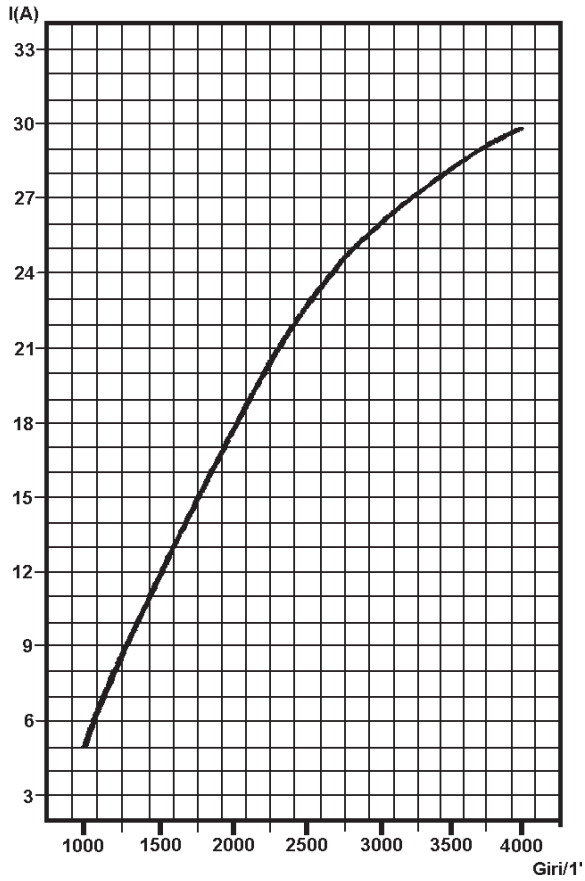

**Alternator battery charger curve 12V 30A
(two cables at output)**

This curve is obtained at 20°C.
The statistical charging output of the flywheel alternator is +10% to -5% of the values shown.

202

Electric starting layout (12V) with flywheel alternator

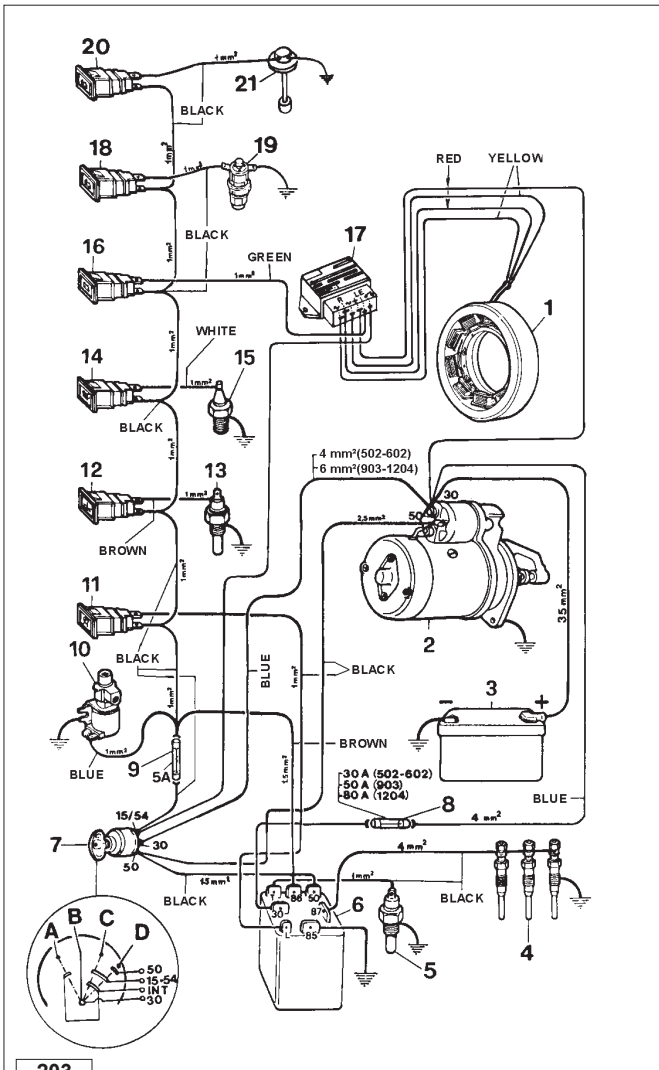

- 1 Alternator
- 2 Starter Motor
- 3 Battery
- 4 Glow Plugs
- 5 Coolant temperature thermistor
- 6 Glow Plug Controller / Timer
- 7 Key Switch
- 8 System Fuse, 50A for KDW 702-1003, 80A for KDW 1404
- 9 Fuse (Accessory)- 5A
- 10 Fuel Solenoid Valve
- 11 Glow Plug Indicator Lamp
- 12 Coolant High Temperature Lamp
- 13 Coolant High Temperature Switch
- 14 Oil Pressure (Low) Lamp
- 15 Oil Pressure Switch
- 16 Alternator Charging Lamp
- 17 Voltage regulator
- 18 Air Filter High Restriction Indicator Lamp
- 19 Air Filter Restriction Switch
- 20 Low Fuel Level Lamp
- 21 Low Fuel Level Switch

- A Accessory Position
- B Off Position
- C On Position
- D Starting Position

Note: Battery 3 not supplied by KOHLER, for battery characteristics see page 96.

203

Voltage regulator connections

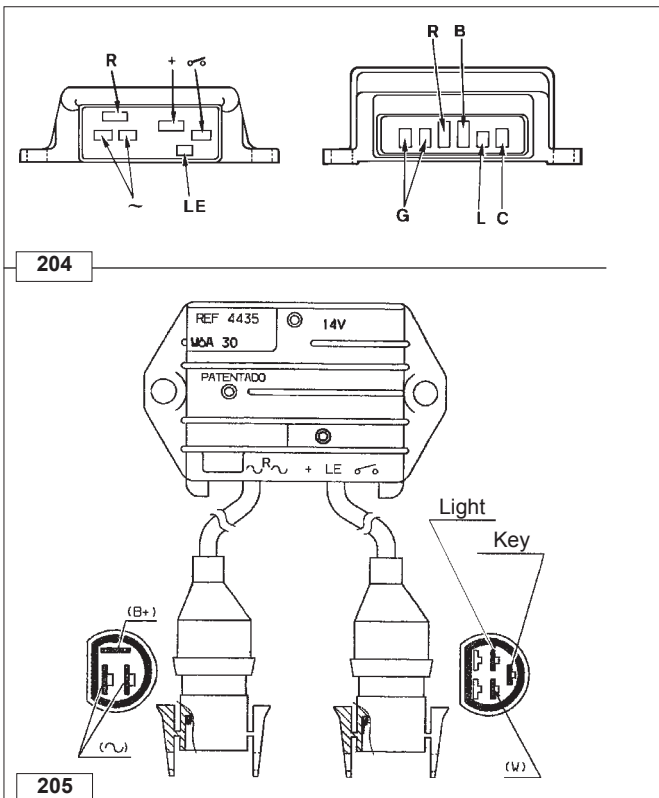

204

205

AETSA SAPRISA NICSA	Cable colour	DUCATI	Connction dimensions	
			Width	Thickness
~	Yellow	G	6,35	0,8
R	Red	R	9,50	1,2
+	Red	B	9,50	1,2
LE	Green	L	4,75	0,5
σ o	Brown	C	6,25	0,8

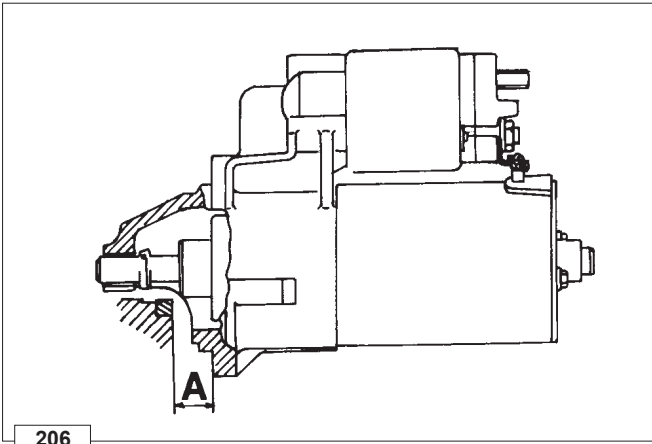

206

STARTER MOTOR - Bosch DW 12V 1,1 KW

Rotation: Clockwise

A = 17,5÷19,5 mm
(distance from starter mounting flange to ring gear face)

Note: Please refer to your local BOSCH distributor for service parts, repair criterion and warranty service.

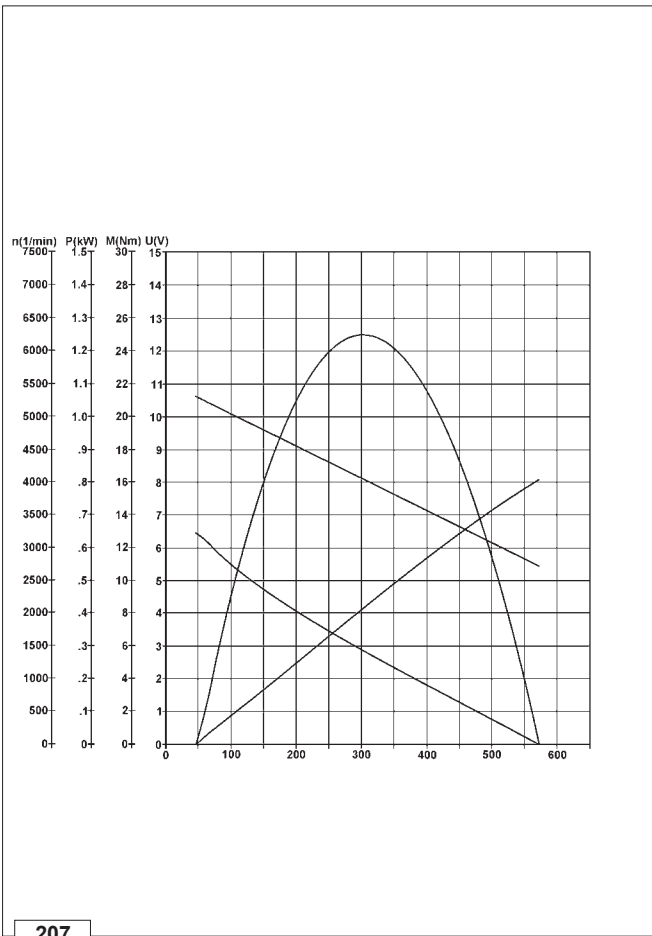

207

Starter motor, Bosch DW 12V 1,1 KW - Performance Curve

The curve was obtained at room temperature of -20°C with a fully charged 66Ah battery.

- U** = Starter Motor Voltag
- n** = Armature r/min
- I** = Absorbed Amperage
- P** = Starter Output Power (KW)
- M** = Starter Output Torque (Nm)

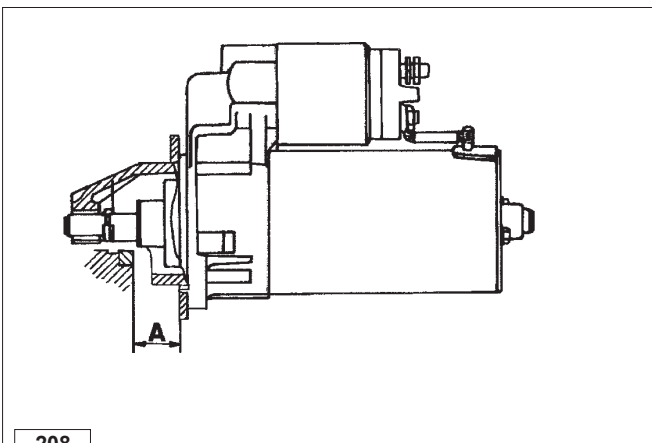

208

Starter motor, Bosch 12V 1,6 KW

Rotation: Clockwise

A = 29,50÷31,5 mm
(distance from starter mounting flange to ring gear face)

Note: Please refer to your local BOSCH distributor for service parts, repair criterion and warranty service.

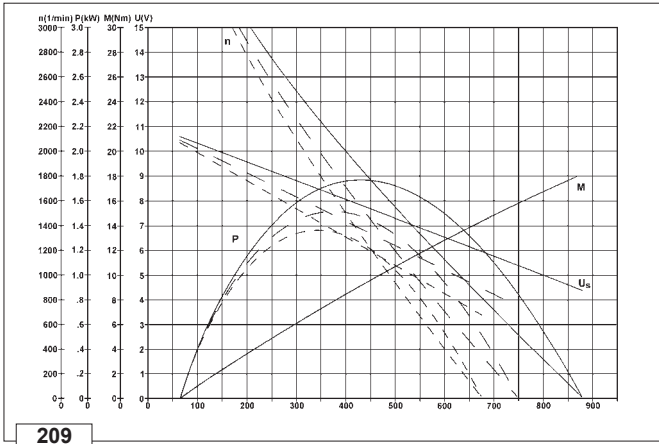

Starter motor, Bosch DW 12V 1,6 KW - Performance Curve

The curve was obtained at room temperature of -20°C with a fully charged 88 Ah battery.

- U** = Starter Motor Voltage
- n** = Armature r/min
- I** = Absorbed Amperage
- P** = Starter Output Power (KW)
- M** = Starter Output Torque (Nm)

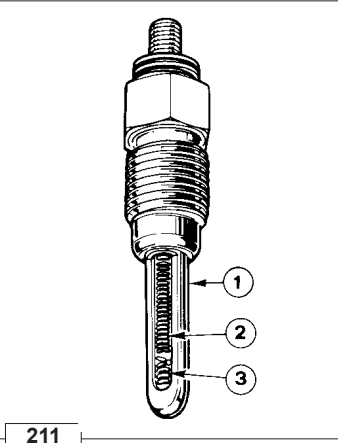
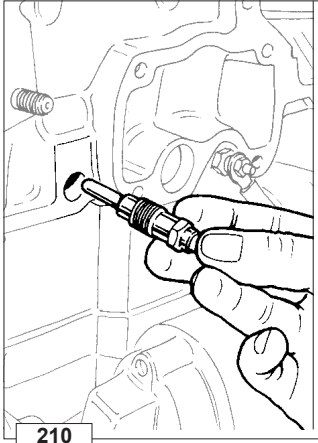

Pre-heating glow plug

Characteristics:
 Nominal voltage..... 12,5V
 Current absorption..... 12A÷14A after 5 seconds
 Sheath surface temperature..... 850°C after 5 seconds.

- Components:*
- 1 Sheath
 - 2 Primary Heating Coil
 - 3 Secondary Heating Coil

○ When remounting tighten at a torque of 20 Nm.

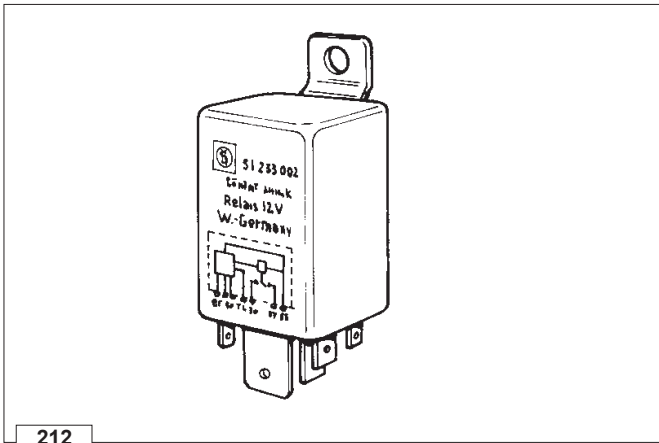

Pre-heating plug control unit with coolant temperature sensor

To avoid white smoke immediately following start-up post-heat for about 5 seconds, see table

Thermistor input		Glow-plug heat time (sec.)	
Resistance (ohm)	Coolant temp. °C	Pre-heat	Post-heat
7000	-20	23,5÷29,5	4,0÷7,0
2400	0	13,5÷16,5	
100	+20	8,5÷10,5	
460	+40	6,0÷8,0	
≤ 320	+50	Heating stop	

➡ For electrical connections see figures 196-199-203.

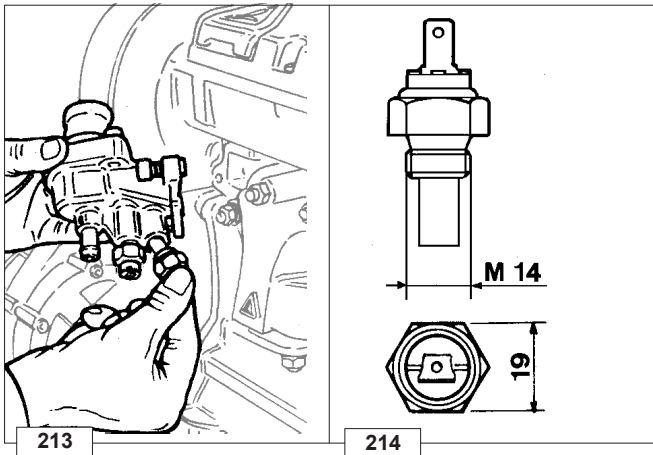

Temperature sensor for control unit

In engines fitted with the above-mentioned type of control unit, the introduction of the glow plugs depends on a temperature sensor that varies preheating temperature in relation to the coolant temperature.

Characteristics:

- Temperature range -30 ÷ +50°C
- Voltage range 6÷24 V
- Temperature max..... 150°C
- Max. tightening torque..... 30 Nm.

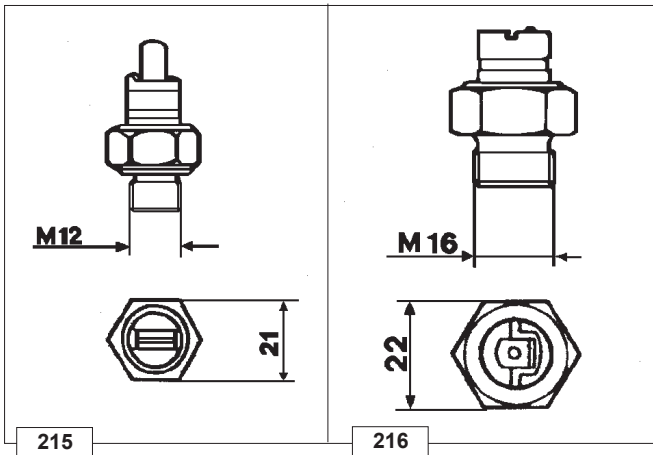

Oil pressure switch (Fig. 215)

Characteristics:

Opening pressure: 0,15÷0,45 bar (for gen-sets: 1,4 bar).

- Tightening torque 25 Nm.

Coolant high temperature lamp sensor (Fig. 216)

Characteristics:

- Circuit single pole
- Voltage range 6÷24 V
- Max. Power Absorption..... 3 W
- Closing temperature 107÷113°C

- Tightening torque 25 Nm.

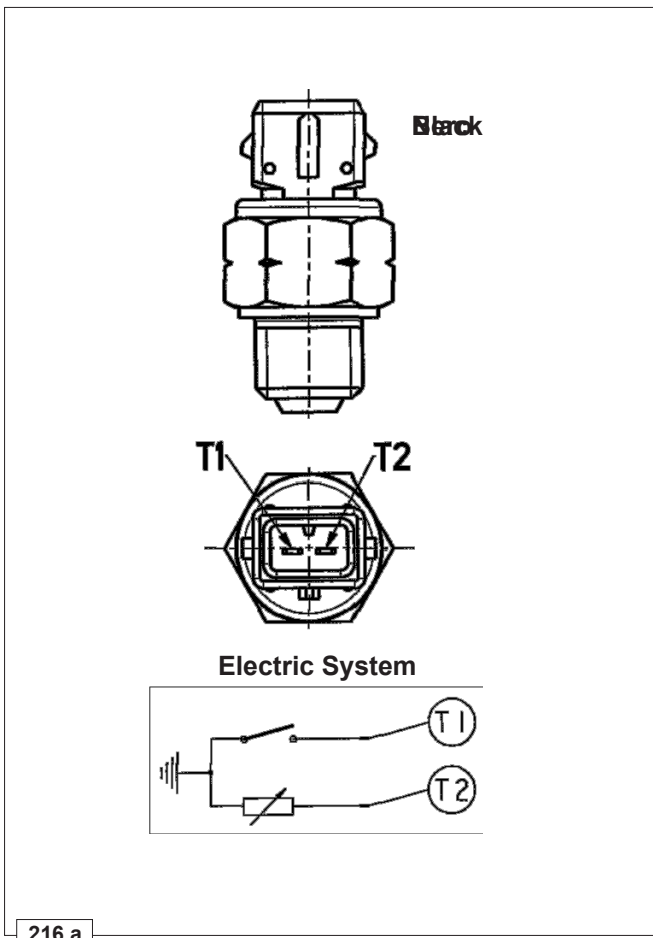

Pre-heating water temperature thermistor and Water temperature indicator thermal contact

T1 thermal contact features:

- Circuit unipolar
- Contact closing temperature..... 110° C ± 3° C
- Contact opening temperature..... > 85° C
- Supply voltage..... 12÷24 V
- Thermocontrol max power..... 3 W

T2 thermal contact features:

Temperature	Resistance
-30	12000
-20	7000
0	2800
+20	1350
+40	750
+60	490
+80	360
+100	300
+120	270

- Tightening torque MAX 30 Nm.

SPEED SETTINGS

Setting the idle minimum (standard)

After filling the engine with oil, fuel and coolant, start it and let it warm up for 10 minutes.

Turn the screw **1** to adjust the idle speed at 850 to 900 rpm.
Tighten then the locknut.

Note: If you loosen screw **1** speed decreases. To the opposite direction speed increases.

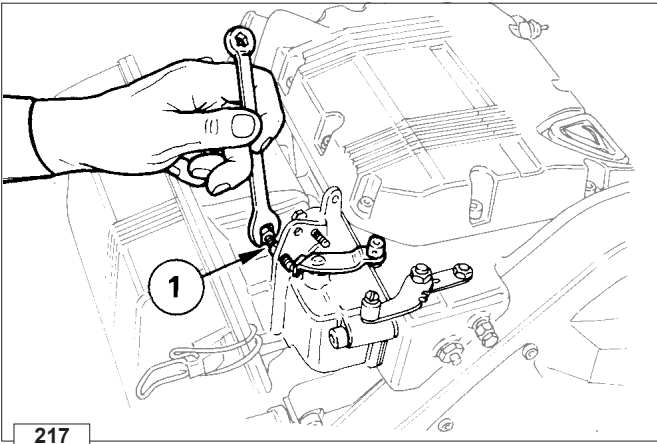

217

Setting the idle maximum (standard)

After setting the idle speed turn screw **2** and regulate the idle maximum at 3800 rpm.

Block then the locknut.

When the engine reaches its setting power, the maximum rpm will stabilise at 3600 rpm.

Note: If you loosen screw **2** speed increases.
To the opposite direction speed decreases.

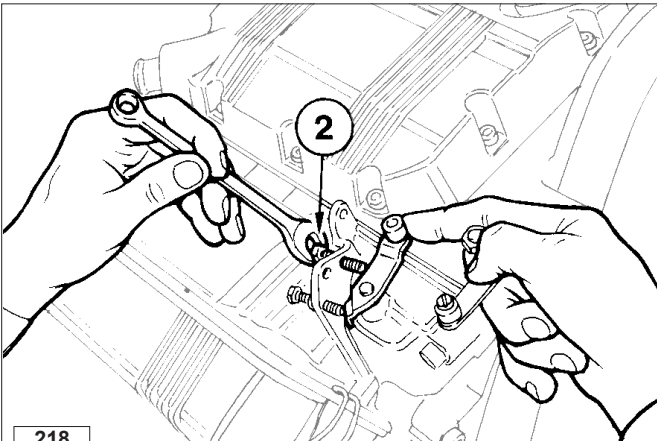

218

Pump injection delivery standard setting without dynamometric brake

This adjustment must be performed with the dynamometric braked engine.

Without this, the regulation is approximate.

In this case proceed as follows:

- Unlock the maximum flow limiter lock nut.
- Fully screw in flow limiter **C**.
- Run the engine to the maximum speed, that is 3800 rpm.
- Loosen flow limiter **C** until the engine revs start to decrease.
- Screw flow limiter **C** by 2.5 turns.
- Tighten the lock nut.

Note: If the engine under maximum load emits too much smoke unscrew **C**. Tighten **C** if at this load there is no smoke and if the engine does not reach its maximum power.

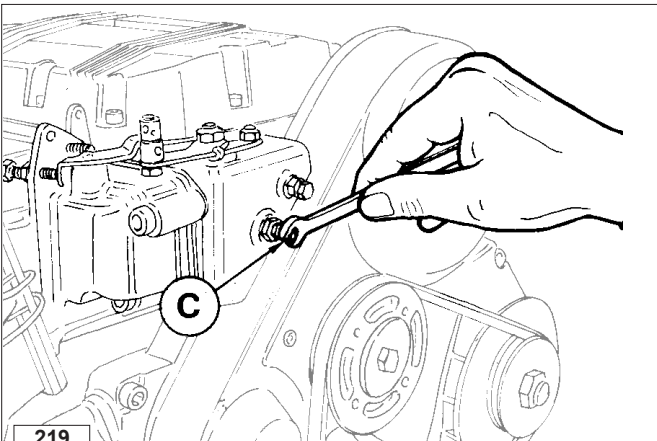

219

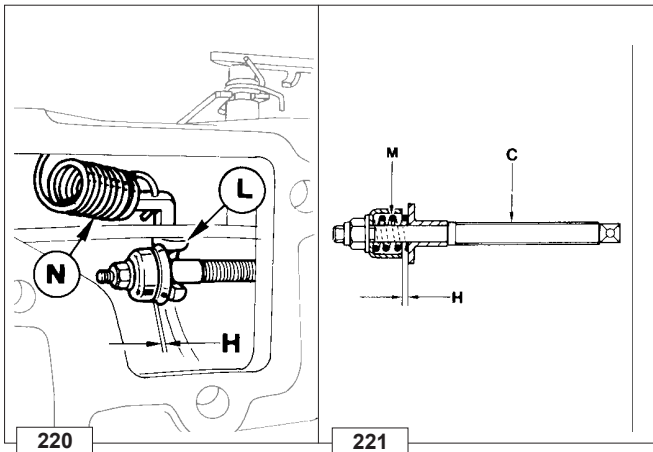

Injection pump flow limiter and engine torque gearing device

Flow limiter **C** has the function of limiting the injection pump's maximum delivery.

The same mechanism acts also as a torque gearing device. Indeed, under torque, spring **N** operating lever **L** overcomes the resistance of spring **M** located in the plunger barrel.

The stroke **H** that the torque gearing device allows to be carried out by lever **L**, will increase the injection pump delivery and the torque will hit its maximum value.



Important

The stroke H varies depending on which engine torque gearing device is fitted on the engine.

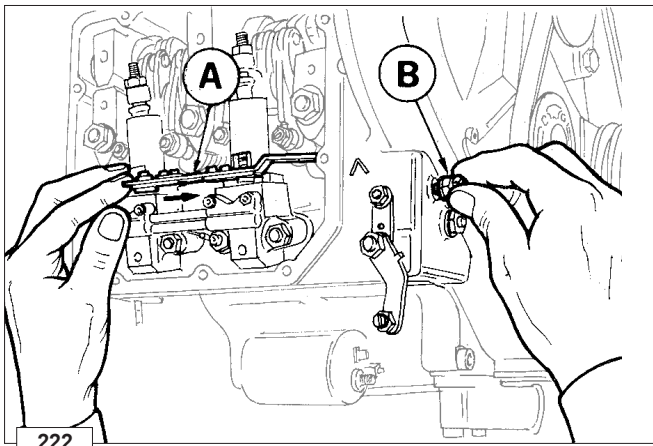

Setting the stop

Remove the rocker arms cover and completely unloosen screw **B**.

Push rod **A** to the right and keep it in this position; see figure.

Tighten screw **B** until it touches rod **A**.

Release rod **A** and tighten again screw **B** by a 0.5÷1.0 turn.

Tighten the lock nut.

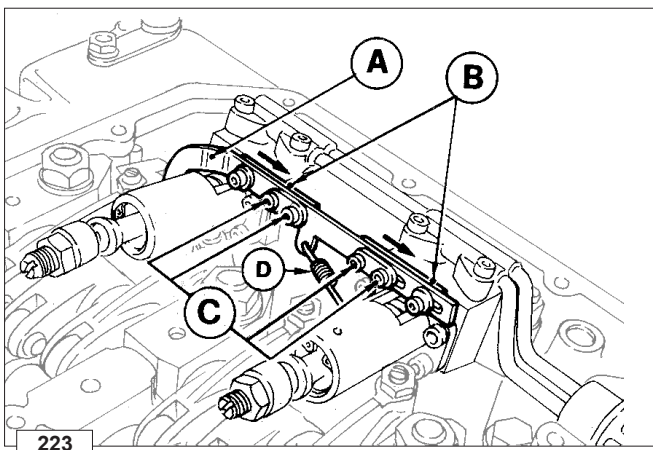

Pump/injector unit timing with speed governor

- Loosen the screws **C** of each pump/injector unit.
- If it is not connected, connect spring **D** to rod **A** (with this operation the speed governor blocks are closed).
- Move plates **B** of each pump/injector unit rightwards; see figure (with this operation the pumps/injector unit are at their maximum delivery).
- Tighten screws **C** at 1.1 Nm. Re-balance the deliveries.

Note: Spring **D** is the start-up fuel supplement spring: with the engine stopped pull rod **A** to the right by bringing the pump/injector unit delivery to the maximum value, until the speed governor comes into operation with the engine running

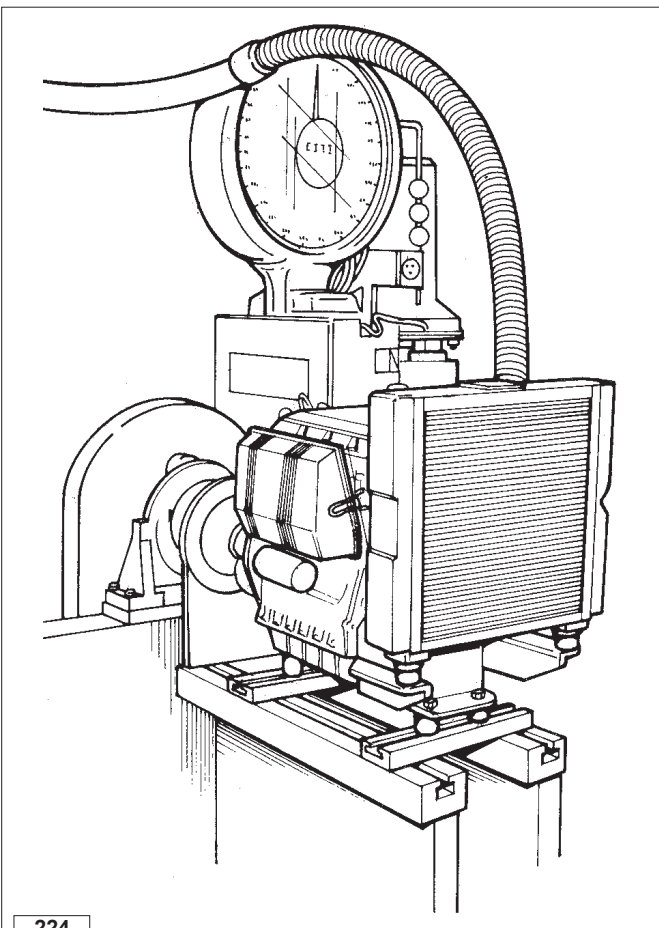

Pump/injector unit delivery setting with braked engine

- 1) Run the engine to the maximum speed.
- 2) Screw flow limiter **C** (see fig. 219).
- 3) Load the engine up to the power and number of revs required by the application's manufacturer.
- 4) Check that consumption is within the values allowed for in the settings table (see below).
If consumption is not within the given figures, it is necessary to change the balance conditions shown to the brake, altering the load and the speed governor. Redo the consumption check on the stabilised engine.
- 5) Unscrew limiter **C** until the engine rpm start to decrease. Lock the limiter using the lock nut.
- 6) Completely release the brake and check the rpm at which the engine stabilises.
The performance of the speed governor must meet the class required by the application's manufacturer.
- 7) Stop the engine.
- 8) Recheck the valve clearance with the engine cold.

224

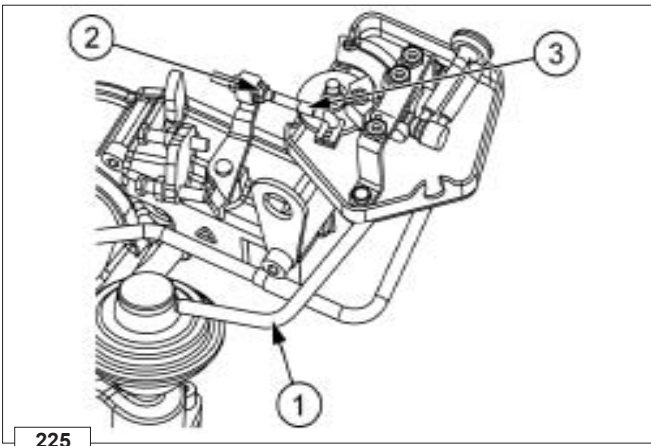

E.G.R. calibration

Mount a T-branch on vacuum valve - E.G.R. valve connection pipe **1**, and connect it to a vacuum pressure gauge with 1 bar bottom scale so as to be able to read the degree of vacuum within the pipe.

Note: It is also possible to use a mercury column, 1 metre long, since the maximum suction pressure exerted by the vacuum pump is 720 mmHg.

Adjust the position of the accelerator lever via the regulator block, so that the internal adjusting nut **2**, is about 5 mm from the end of the thread.

Accelerate the engine up to 3.600 rpm (with valve closed: this means that the value showed on the vacuum pressure gauge or on the mercury column should be 0.

In case it is different from zero, adjust the regulator block nuts to move it, in relation to the rod **3**, in the direction that goes from the flywheel to the timing.

With the brake at a braking curve $N=\text{constant}$, "load" the engine slowing it down to 2.800 rpm.

Acting on the accelerator look for the E.G.R. valve closing point (pressure of the vacuum pressure gauge or mercury gauge equal to zero).

Note: Pay attention to determine the precise closing point: by slightly accelerating the engine the vacuum value in the E.G.R. operation pipe should immediately increase.

Measure the engine consumption in order to calculate the $\text{mm}^3/\text{stroke}$ value.

If the calculated value is less than $18.8 \text{ mm}^3/\text{stroke}$, adjust the adjusting nut making it closer to the end of the rod **3** to "increase the calibration".

When the required value of $18.8 \text{ mm}^3/\text{stroke}$ has been reached (and a power of around 7 KW) tighten the adjusting nuts.

ENGINE STORAGE

- When the engines are not for more than 6 months, they have to be protected performing the operations described in the following pages.
- If the engine is not to be used for extensive periods, check the storage area conditions and the type of packaging and make sure that these are suitable for correct storage.
If necessary, cover the engine with a proper protective sheet.
- Avoid storing the engine in direct contact with the ground, in environments that are humid and exposed to bad weather, near high voltage electric lines, etc.

**Important**

If, after the first 6 months, the engine is still not used, it is necessary to carry out a further measure to extend the protection period (see "Protective treatment").

PROTECTIVE TREATMENT

- 1 - Pour in the engine housing AGIP RUSTIA C protective oil up to the maximum level.
- 2 - Fill up with fuel containing 10% AGIP RUSTIA NT.
- 3 - Make sure that the coolant is up to the maximum level.
- 4 - Start the engine and keep it idle at minimum speed for some minutes.
- 5 - Bring the engine to $\frac{3}{4}$ of the maximum speed for 5÷10 minutes.
- 6 - Turn off the engine.
- 7 - Empty out completely the fuel tank.
- 8 - Spray SAE 10W on the exhaust and intake manifolds.
- 9 - Seal the exhaust and intake ducts to prevent foreign bodies from entering.
- 10 - Thoroughly clean all external parts of the engine using suitable products.
- 11 - Treat non-painted parts with protective products (AGIP RUSTIA NT).
- 12 - Loosen the alternator/fan belt.
- 13 - Cover the engine with a proper protective sheet.

**Caution - Warning**

In countries in which AGIP products are not available, find an equivalent product (with specifications: MIL-L-21260C).

**Important**

Maximum every 24 months of inactivity, the engine must be started up by repeating all "Engine Storage" operations.

PREPARING THE ENGINE FOR OPERATION AFTER PROTECTIVE TREATMENT

After the storage period and before starting up the engine and preparing it for operation, you need to perform certain operations to ensure maximal efficiency conditions.

- 1 - Remove the protective sheet.
- 2 - Remove any sealing devices from the exhaust and intake ducts.
- 3 - Use a cloth soaked in degreasing product to remove the protective treatment from the external parts.
- 5 - Inject lubricating oil (no more than 2 cm³) into the intake ducts.
- 6 - Adjust the alternator/fan belt tension.
- 7 - Turn the engine manually to check the correct movement and smoothness of the mechanical parts.
- 8 - Refill the tank with fresh fuel.
- 9 - Make sure that the oil and the coolant are up to the maximum level.
- 10 - Start the engine and after some minutes bring it to $\frac{3}{4}$ of the maximum speed for 5-10 minutes.
- 11 - Turn off the engine.
- 12 - Remove the oil drain plug (see "Oil replacement") and discharge the AGIP RUSTIA NT protective oil while the engine is hot.
- 13 - Pour new oil (see "Table of lubricants") up to the maximum level.
- 14 - Replace the filters (air, oil, fuel) with original spare parts.
- 15 - Empty the cooling circuit completely and pour in the new coolant up to the maximum level.

**Caution - Warning**

Over time, a number of engine components and lubricants lose their properties, so it is important considering whether they need replacing, also based on age (see Replacement table).

**Important**

Maximum every 24 months of inactivity, the engine must be started up by repeating all "Engine Storage" operations.

Table of tightening torques for the main components

POSITION	Riference (figure and page n°)	Diam. & pitch (mm)	Torque (Nm)	Sealant
Injection pump control rod	62÷63 - p. 54	M 3 spec.	1,1	
Connecting rod ****	116 - p. 68	8x1	40	
Union for the nozzle	131÷132 - p. 71	8x1,25	12	
Glow-plugs	210÷211 - p. 102	12x1,25	20	
Oil filter cartridge (M 20x1,5 union)		20X1,5	15	270
Camshaft bearing (M 6 screws)		6	10	270
Rocker arm cover	55 - p. 53	6x1	9	638
Main bearing caps	126÷130 - p. 70	M 10	60	
Oil pan	97÷98 - p. 62	M 6	10	Silicon 7091
Camshaft bearing support screw	50 - p. 51	M 6	10	
Glow-plug cable nuts		5x0,8	5	
Fuel lift pump nuts	167 - p. 84	8x1,5	24	
Belt tensioner nut	39 - p. 48	M 10	40	
External Stop control lever nut		8x1,25	8	
Pump/injector unit fixing nut	181 - p. 89	M 8	20*	
Rocker arm assembly support nut	68 - p. 55	M 10	40	
Fuel pump cam	146 - p. 75	10x1,25	45	
Flywheel side oil seal ring flange		M 6	12	
Pre-combustion chamber ring nut	90÷96 - p. 61	30x1,5	**	
Vacuum pump fixing screws	13÷14 - p. 42	10x1,25	50	270
Belt tensioner		10	15	242
Crankcase		12x1,5		
Speed governor lever screw		6x1	7	
Driving pulley	22÷24 - p. 44	16x1,5 sin.	360	
Camshaft timing pulley	34 - p. 47	10x1,25	80	
Oil pressure switch	215 - p. 103	12x1,5	25	
Oil drain plug	152÷153 - p. 79	12x1,5	40	242
Cylinder headù	113÷115 - p. 67	18	***	
Injection pipe	64 - p. 54	TCEI 4x1,5	4	
Flywheel	21 - p. 44	10x1,5	80	

* Tighten the two nuts that fasten each pump/injector unit at the same time. For engines with the injectors fixed with self-locking nuts, tighten the nuts at 23 Nm.

** Tighten these in two phases: the first phase at 100 Nm, the second phase at 180 Nm. See page 51, figures 95-96.

*** See page 57

**** Aluminium connecting rod with 35 Nm tightening torque.

Table of tightening torques for standard screws (coarse thread)















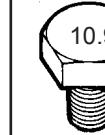
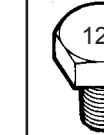
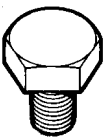
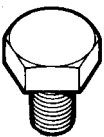
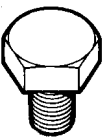
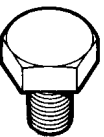
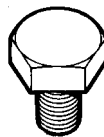
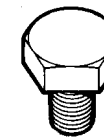
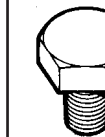
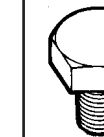
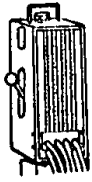

Resistance class (R)								
Quality/ Dimensions								
Diameter	R>400N/mm ²		R>500N/mm ²		R>600N/mm ²	R>800N/mm ²	R>1000N/mm ²	R>1200N/mm ²
	Nm	Nm	Nm	Nm	Nm	Nm	Nm	Nm
M3	0,5	0,7	0,6	0,9	1	1,4	1,9	2,3
M4	1,1	1,5	1,4	1,8	2,2	2,9	4,1	4,9
M5	2,3	3	2,8	3,8	4,5	6	8,5	10
M6	3,8	5	4,7	6,3	7,5	10	14	17
M8	9,4	13	12	16	19	25	35	41
M10	18	25	23	31	37	49	69	83
M12	32	43	40	54	65	86	120	145
M14	51	68	63	84	101	135	190	230
M16	79	105	98	131	158	210	295	355
M18	109	145	135	181	218	290	405	485
M20	154	205	193	256	308	410	580	690
M22	206	275	260	344	413	550	780	930
M24	266	355	333	444	533	710	1000	1200
M27	394	525	500	656	788	1050	1500	1800
M30	544	725	680	906	1088	1450	2000	2400

Table of tightening torques for standard screws (fine thread)

Resistance class (R)								
Quality/ Dimensions								
Diameter	R>400N/mm ²		R>500N/mm ²		R>600N/mm ²	R>800N/mm ²	R>1000N/mm ²	R>1200N/mm ²
	Nm	Nm	Nm	Nm	Nm	Nm	Nm	Nm
M 8x1	10	14	13	17	20	27	38	45
M 10x1	21	28	26	35	42	56	79	95
M 10x1,25	20	26	24	33	39	52	73	88
M 12x1,25	36	48	45	59	71	95	135	160
M 12x1,5	38	45	42	56	68	90	125	150
M 14x1,5	56	75	70	94	113	150	210	250
M 16x1,5	84	113	105	141	169	225	315	380
M 18x1,5	122	163	153	203	244	325	460	550
M 18x2	117	157	147	196	235	313	440	530
M 20x1,5	173	230	213	288	345	460	640	770
M 20x2	164	218	204	273	327	436	615	740
M 22x1,5	229	305	287	381	458	610	860	1050
M 24x2	293	390	367	488	585	780	1100	1300
M 27x2	431	575	533	719	863	1150	1600	1950
M 30x2	600	800	750	1000	1200	1600	2250	2700

SPECIAL TOOLS	DESCRIPTION	Part N°.
	Injection pumps delivery balancing instrument	7107.1460.127
	Precombustion chamber extractor	7107.1460.030
	Injection pump static injection advance tester(old type)	7271.1460.024
	Sheet metal for insertion of main bearings in the crankcase	7107.1460.053
	Ring nut wrench for fastening pump/injector pumping element	7107.1460.029
	Precombustion chamber wrench	7107.1460.027
	Precombustion chamber adjusting rod	7107.1460.031
	Coupling for static injection advance control and setting of old-type injection pumps injector	7107.1460.028
	Device for mounting valve guide gasket, intake and exhaust side	7107.1460.047
	Valve lowering device for injection advance control	7107.1460.048
	Timing belt tightening tool	7107.1460.049
	Crankshaft clamping tool	7107.1460.051
	Tool for injection advance control and setting of injector for pump/injector unit: se.no. 6590-272	7107.1460.056
	Tool for injection advance control and setting of injector for pump/injector unit: se.no. 6590-285, 6590-307, 6590-290	7107.1460.074

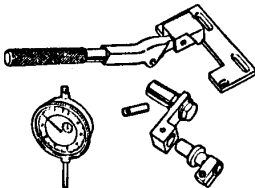
Translated from the original manual in Italian language.

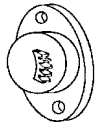
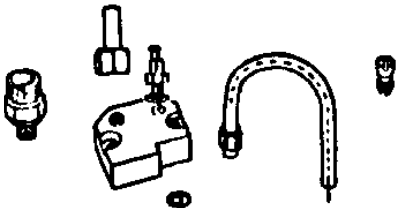
Data reported in this issue can be modified at any time by KOHLER.

KOHLER®

FOR SALES AND SERVICE INFORMATION
IN U.S. AND CANADA, CALL **1-800-544-2444**

KohlerEngines.com

ENGINE DIVISION, KOHLER CO., KOHLER, WISCONSIN 53044

FORM NO.	ED0053029340		
ISSUED	06/20/2012		
REVISED	00	DATE	06/20/2012