



BATTERY OPERATED CONCRETE VIBRATOR MANUAL

MODELS E-VIB & ECO VIB



E-VIB



ECO-VIB

ECOLOGICAL VIBRATOR

EC DECLARATION OF CONFORMITY / DECLARATION CE DE CONFORMITE / DECLARACIÓN DE CONFORMIDAD CE / DECLARAÇÃO CE DE CONFORMIDADE / ДЕКЛАРАЦИЯ О СООТВЕТВИИ ЕС / EC DECLARAȚIE DE CONFORMITATE

- GB/US
- F
- E
- P
- RUS
- RO

We, **Uni-corp Europe, 33 Avenue Pierre Brossolette, 94048 Créteil Cedex, France**, hereby certify that if the product described within this certificate is bought from an authorised Paclite dealer within the EEA, it conforms to the following directives: Machinery Directive 2006/42/EC, Electromagnetic Compatibility Directive 2004/108/EC (as amended by 92/31/EEC & 93/68 EEC). The physical agent (vibration) conforms with the directive 2002/44/EC. The low voltage directive 2006/95/EC, BS EN ISO 12100-1/2 Safety of machinery and associated harmonised standards, where applicable. Noise emissions conform to directive 2005/88/EC Annex VI), for machines under article 12 the notified body is **TÜV Rheinland Product Safety GmbH - Am Grauen Stein - D-51105 Köln, Germany**.

Nous soussignons, **Uni-corp Europe, 33 Avenue Pierre Brossolette, 94048 Créteil Cedex, France**, certifions que si le produit décrit dans ce certificat est acheté chez un distributeur de la marque déposée "Paclite" au sein de la EEA, celui-ci est conforme aux norms CEE ci-après: Norme de la machine 2006/42/CE, Norme compatible pour l'électromagnétisme 2004/108/CE (modifié par 92/31/CEE et 93/68/CEE). Le nombre de vibrations est en accord avec la directive 2002/44/CE. Caractéristiques basse tension 2006/95/CEE, BS EN ISO 12100-1/2, Norme de sécurité des machines et des critères associés et configurés, si applicable. Les émissions de bruit sont conformes à la directive 2005/88/CE Annexe VI pour machines, article 12. L'objet mentionné est **TÜV Rheinland Product Safety GmbH - Am Grauen Stein - D-51105 Köln, Allemagne**.

La Sociedad, **Uni-corp Europe, 33 Avenue Pierre Brossolette, 94048 Créteil Cedex, France**, por el presente documento certifica que si el producto descrito en este certificado es comprado a un distribuidor autorizado de Paclite en la EEA, este es conforme a las siguientes directivas: 2006/42/CE de la CEE, Directiva 2004/108/CEE sobre Compatibilidad Electromagnética (según enmiendas 92/31/CEE y 93/68 CEE). El numero de vibraciones esta de acuerdo con la Directiva 2002/44/CE. Directiva sobre Bajo Voltaje 2006/95/CEE, BS EN ISO 12100-1/2 de Seguridad de Maquinaria y Niveles armonizados estándares asociados donde sean aplicables. Emisión de Ruidos conforme a la Directiva 2005/88/CE Anexo VI para máquinas bajo artículo 12 la mencionada unidad está **TÜV Rheinland Product Safety GmbH - Am Grauen Stein - D-51105 Köln, Germany**.

O signatário, **Uni-corp Europe, 33 Avenue Pierre Brossolette, 94048 Créteil Cedex, France**, pelo presente, declara que se o produto descrito neste certificado foi adquirido a um distribuidor autorizado do Paclite em qualquer país da EEA, está em conformidade com o estabelecido nas seguintes directivas comunitárias: 2006/42/CE, Directiva de Compatibilidade Electromagnética 2004/108/CEE (conforme corrigido pelas 92/31/EEC & 93/68 EEC). O numero de vibrações está de acordo com a directiva 2002/44/CE LB. A directiva de baixa voltagem 2006/95/CEE, BS EN ISO 12100-1/2 Segurança da maquinaria e às normas harmonizadas afins se aplicáveis. As emissões de ruído respeitam e estão dentro das directivas para máquinas 2005/88/CE Anexo VI, artigo 12, sendo o organismo notificado **TÜV Rheinland Product Safety GmbH - Am Grauen Stein - D-51105 Köln, Germany**.

Мы, компания **Uni-corp Europe, 33 Avenue Pierre Brossolette, 94048 Créteil Cedex, France**, настоящим подтверждаем, что если упомянутая в настоящей декларации продукция приобретена у уполномоченного представителя Paclite в Европейской экономической зоне, она отвечает требованиям перечисленных ниже директив: Директива по машиностроению 2006/42/ЕС, Директива о электромагнитной совместимости 2004/108/ЕС (с добавлениями 92/31/ЕЕС и 93/68 ЕЕС). Рабочее воздействие (вибрация) соответствует требованиям Директивы 2002/44/ЕС. Директива о низковольтном оборудовании 2006/95/ЕС, BS EN ISO 12100-1/2 Гармонизированные стандарты по безопасности машин и связанные с ними другие гармонизированные стандарты (где применимо). Шумовое воздействие в соответствии с директивой 2005/88/ЕС Приложение VI). Для машин, соответствующих требованиям статьи 12, уполномоченным органом является **TÜV Rheinland Product Safety GmbH - Am Grauen Stein - D-51105 Köln, Germany**.

Noi, **Uni-corp Europe, 33 Avenue Pierre Brossolette, 94048 Créteil Cedex, France**, prin prezenta certificăm că produsul descris în acest certificat și cumpărat de la un distribuitor autorizat Paclite din EEA, este realizat în conformitate cu următoarele directive: Directiva pentru echipamente 2006/42/EC, Directiva privind compatibilitatea electromagnetică 2004/108/EC (modificată conform 92/31/EEC & 93/68 EEC). Agentul fizic (vibrația) este conform cu directiva 2002/44/EC. Directiva pentru curenți mici 2006/95/EC, BS EN ISO 12100-1/2 Siguranța echipamentelor și asociată standardelor armonizate, unde este aplicabil. Emisiile de zgomot conform directivei 2005/88/EC Annex VI), pentru echipamente la articolul 12 certificată de **TÜV Rheinland Product Safety GmbH - Am Grauen Stein - D-51105 Köln, Germania**.

PRODUCT TYPE.....	TYPE DE PRODUIT....	TIPO DE PRODUCTO..	TIPO DE PRODUCTO..	ТИП ИЗДЕЛИЯ.....	TIP PRODUS.....
MODEL.....	MODELE.....	MODELO.....	MODELO.....	МОДЕЛЬ.....	MODEL.....
SERIAL No.....	Nº DE SERIE.....	Nº DE SERIE.....	Nº DE SÉRIE.....	СЕРИЙНЫЙ №.....	SERIE
DATE OF	DATE DE	FECHA DE	DATA DE	ДАТА	DATA
MANUFACTURE.....	FABRICATION.....	FABRICACIÓN.....	FABRICO.....	ИЗГОТОВЛЕНИЯ....	DE PRODUCTIE.....
WEIGHT.....	POIDS.....	PESO.....	PESO.....	МАССА.....	GREUTATE.....



Signed by:
Signature:

Anita Tan

Quality Manager - On behalf of Uni-corp Europe
Directrice de Qualité - au nom de Uni-corp Europe S.A.R.L.

☆ SAFETY PRECAUTIONS

- ☆ This vibrator is designed for use when compacting concrete.
Do not use the vibrator for any other purpose.
- ☆ For safety operation, be sure to read this operation manual completely and understand the contents and the Danger, Warning and Caution messages before operation. Improper machine use may result in injury or failure.
- ☆ The following symbols are DANGER, WARNING, and CAUTION labels for the use of this product so that the product will not cause harm or damage to users or others.
- ☆ Also read the operation manual of the lithium ion batteries charger before use.



DANGER

【DANGER】 indicates an imminent dangerous situation which may lead to death or serious injury.



WARNING

【WARNING】 refers to a hazard that may cause death or serious injury.



CAUTION









【CAUTION】 refers to a hazard that may cause minor or moderate injury.

 DANGER

(To prevent Accidents)

- ⚠ Keep this product away from atmosphere containing flammable or combustible gas.
Do not use, charge or store it near fire or the hot sun.
It may result in Fire, rupture, or liquid leakage.
- ⚠ Do not put the battery on the fire. When the battery is burned, toxic gases and hazardous substance may be generated.
- ⚠ Be sure to use the dedicated battery B1840 when using the vibrator.
It may result in liquid leakage, high-heat generation, ignition, or explosion.
- ⚠ Be sure to use battery charger C1860L for battery B1840. Never use other battery charger. Do not use the charger for any purpose other than charging Battery B1840. It may result in liquid leakage, high-heat generation, ignition, or explosion.
- ⚠ Do not disassemble or modify the vibrator, charger, or battery.
- ⚠ Do not use the vibrator, replace the battery, or charge the battery in a place exposed to rain or water, or with wet hands. It may result in electric shock or malfunction.
- ⚠ Do not store batteries with nails, screwdrivers, or metal boxes. By contacting metal with the battery terminal may cause a short circuit, resulting in fire, high-heat generation, electric shock, or damage.
- ⚠ Do not damage the battery, such as sticking with a nail, throwing, or dropping.
It may result in high-heat generation, ignition, or explosion. Do not use or charge the damaged battery. Otherwise, it may cause heat generation, ignition, explosion, or explosion.
- ⚠ If the battery liquid get into the eyes or attach to the skin, wash it with clean water, such as tap water immediately. After that, consult a doctor.
If the damaged battery leaks, wear rubber gloves to avoid to contact it directly. Take off the clothes immediately if the liquid adheres to them. Direct touching may cause skin damage.

 **WARNING**
(To prevent accidents)

-  Do not use the charger in a humid or wet place. A well-ventilated place is recommended. Otherwise, it may result in smoking, heat, fire, or electric shock. Do not block the ventilation holes of the charger. Clean the ventilation holes to ensure adequate air circulation.
-  Be sure to pull out the power plug of the charger when unplugging it. Do not pull the power cord to unplug.
Be careful not to break the power cord due to deterioration caused by heat or oil or sharp projections. If the power cord or power plug is damaged, replace the charger. It may cause a short circuit, a fire, heat, electric shock, or damage.
-  During charging, use the charger at an ambient temperature within the range of 10°C to 45°C. Charging at temperature outside the range may cause fatal damage to the battery.
-  Unplug the power plug from the outlet before cleaning the charger.
Remove the battery from the main unit before maintenance.
-  Store and use the battery, charger and vibrator in place where out of reach of children for safety reason.
-  Do not store batteries in locations where the ambient temperature exceeds 40°C or humidity is high. Smoke, heat, or malfunction may result (in hot sun, a car in the summer, a box made of metal near a heating appliance or a warehouse with poor ventilation).
-  Do not put the battery in a microwave oven or a high-pressure container.
The inside of the battery may be damaged, resulting in heat generation, ignition, or explosion.
-  During charging or using the vibrator, if abnormal odor, heat generation, fuming, deformation, discoloration occurs, stop using it immediately and remove the battery. It may cause ignition, overheating or explosion.

 **WARNING**
(To prevent accidents)

-  Be sure to connect the charger to the AC230V outlet when using the charger.
Do not use it at other voltages. Otherwise, rapture, fire, smoking, high-heat, electric shock may result.









-  Do not put combustible material like a cloth on the battery or charger while the battery is being charged.
Otherwise ignition, heat generation, or rapture may result.

-  Remove the battery from the charger if charging is not completed even after charging for a long time. Otherwise heat generation, ignition, or rapture may result.

-  Do not use batteries if it is extremely short operating time. It may cause high-heat, ignition, or leakage.

-  Be sure to read the operation manual and label descriptions of the charger.
Be sure to understand them well before using the product.

 **CAUTION**
(To prevent injury or damages)

-  The entrepreneur dealing with concrete vibrator has to manage working hours, and has to strive for a workers vibration obstacle prevention.
Refer to the Vibration total value (pg.14) for the details about vibration of vibrator. Observe the relevant legal instructions and guidelines of the country that use the vibrator.
-  The head assembly of this product is cooled when placed in ready-mixed concrete. Thus, do not use it outside the ready-mixed concrete (i.e. in the air).
The head assembly becomes hot during operation. After use, be careful not to touch it. There is a risk of being burned.
-  Do not swing around with the vibrator body.
There is a possibility that this could cause injury or damage to people or objects nearby.
-  Check that the vibrator is not damaged, cracked, or deformed when dropped or hit the vibrator. Injury or electric shock may result.
-  Unplug the charger from the outlet except during charging.
Fire, heat, or electric shock may result.
-  Before starting operation, make sure that the motor and vibrator are properly set. If not, flexible shafts may swing around and it may cause damage (C28F type).
-  Charge the battery periodically. If you do not use the product for a long time, the battery may be damaged.
Charge the battery fully once every half year. When storing for a long time, be sure to charge completely before store.
-  When recharging with an extension cord, use 1.25mm² or more (AWG16) extension cord.
Use the extension cord of the rubber insulated cable for outdoor use. Fire or electric shock may result if an extension cord with incorrect wiring or damaged or disconnected wiring is used.
-  The head assembly becomes hot during operation. After use, be careful not to touch it. There is a risk of being burned.

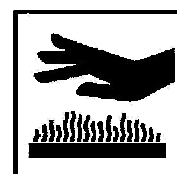



○ INTRODUCTION

Thank you very much for purchasing the handy hard shaft and handy flexible shaft cordless E-VIB vibrator.

Be sure to read this operation manual before use.

For better understanding, read the operation manual of the lithium ion batteries charger before use.

Be sure to read and understand this operation manual carefully before using the product until it can be operated safely and efficiently. Handle and maintain the product appropriately for safety operation.

Keep this manual for further reference.

CONTENTS

☆ SAFETY PRECAUTIONS.....	1
⚠ DANGER.....	2
⚠ WARNING.....	3
⚠ CAUTION.....	5
○ INTRODUCTION.....	6
○ SAFETY.....	7
⚠ CAUTION.....	7
(For personal protection during operation).....	7
⚠ CAUTION.....	8
(For longer service life).....	8
○ PART OF NAMES.....	9
○ CONNECTING THE HARD SHAFT AND FLEXIBLE SHAFT.....	10
○ OPERATIONS.....	11
○ HOW TO REMOVE AND ATTACH THE BATTERY.....	12
○ CLEANING AND TRANSPORTATION AFTER USE.....	12
○ INSPECTION.....	13
○ REPLACEMENT PERIOD FOR CONSUMABLES.....	13
○ TROUBLESHOOTING.....	14
○ SPECIFICATIONS.....	14

○ SAFETY



(For personal protection during operation)

- Put on a safety helmet, safety boots, anti-vibration gloves, face protector (safety glasses and mask) and safety belt before using the vibrator.



Safety Helmet



Safety Boots

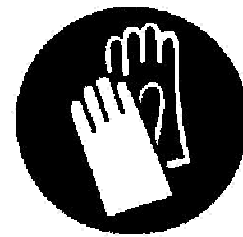

Safety Gloves

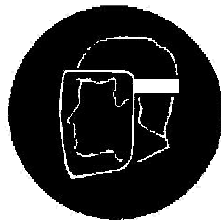

Safety face protector

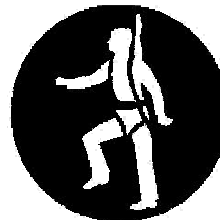

Safety Belt

- If the work place is hard to stand on, such as reinforcing steel, lay a plate on it to gain the scaffold for walking.
- If the machine stops suddenly, turn off the switch and remove the battery. Otherwise, the motor may burn or electric shock may occur.
- When using the vibrator near feet or in places that are not very deep, concrete may be splattered around. Use a face protector (e.g. safety glasses and mask) to protect your eyes and mouth.

 **CAUTION**

(For longer service life)

- The power switch should be turned ON/OFF only when the head assembly is not inserted in the ready-mixed concrete.

If the power is turned OFF,

while it is the vibrator is inserted in the ready-mixed concrete, it may not be able to remove the head assembly.

Forcibly pulling it out may cause injury.



- Do not pry or twist the vibrator with a small force among the reinforcing bars or the mold form with the head assembly. Otherwise the vibration unit may become abraded.

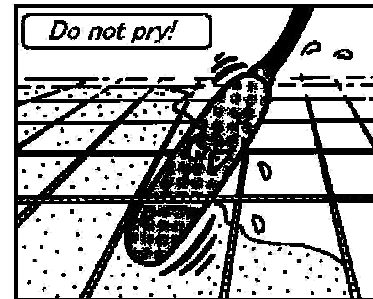

- Do not place heavy objects on the product.
- The head assembly of this product should not be operated on hard surfaces such as concrete or steel plate. Bearings and shafts might be damaged.
- Do not attach or detach the battery while the switch is turned on. Otherwise the motor or battery terminal may be damaged.
- Do not turn on the switch within 3 seconds after turning it off. The protection circuit of the battery may work and the vibrator may not start up.
- Be careful to prevent entering water and concrete into the motor from the ventilation holes during operation. Motor assembly and batteries may be damaged.
- If the motor assembly went under the water, pull it out immediately. Turn off the power and then, remove the battery.

○ PART OF NAMES

E-VIB

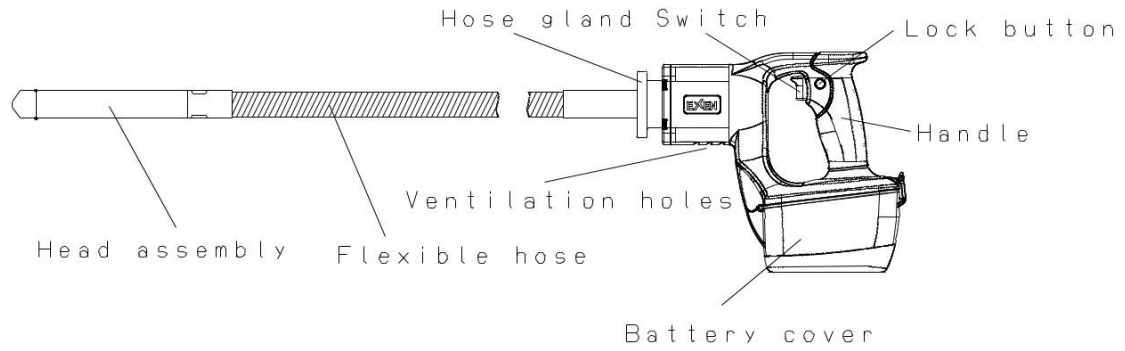

○ CONNECTING THE HARD SHAFT AND FLEXIBLE SHAFT

■ C28F

1. Insert the vibrator assembly shaft joint into the motor assembly.
2. Screw the hose gland of the vibrator assembly into the motor.
3. Hit the hose gland with a hammer for installation.

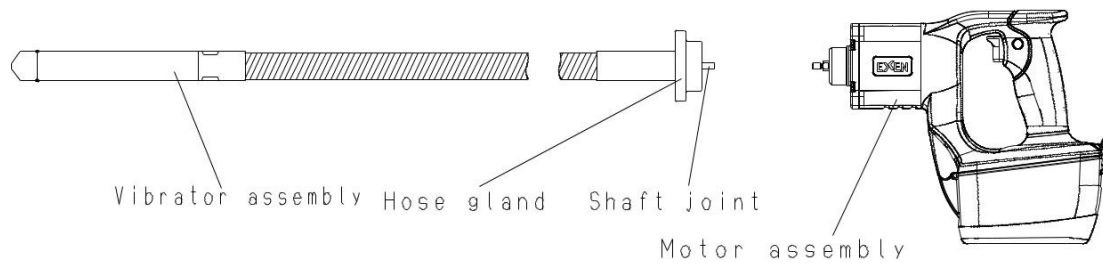



○ OPERATIONS

1. Make sure that the motor assembly switch is OFF.
2. Make sure that the motor assembly and vibrator assembly are securely connected.
3. Attach the battery to the motor assembly and close the battery cover.
4. Hold the handle and then, head assembly.
5. Turn ON the switch of the motor assembly.
 - ※ “When turning on the switch after turning it off within 3 seconds, the protection circuit of the battery may work and the motor may not start up.
 - ※ Push the switch lock button when use continuously.
6. Insert the vibrator perpendicularly into the concrete at a pitch in the effective compacting range.
 - ※ The effective compacting range for the vibrator is an area that has a diameter approximately 10 times the diameter of the vibrating part.
 - ※ After the vibrator has been inserted into the concrete as far as it will go, operate it until the mortar uniformly comes to the surface and has a luster to it, then move on to the next location.
 - ※ If placing a vibrator to one point for long time, it may cause aggregate separation.
7. When removing the vibrator from the concrete, remove it gently so that no hole is left.
8. After work has been completed turn the motor switch OFF.
9. Remove the battery from the main unit.
 - ※ Charge the battery after use.

○ HOW TO REMOVE AND ATTACH THE BATTERY

- Be sure to take your hand off the switch when attaching or detaching the battery.

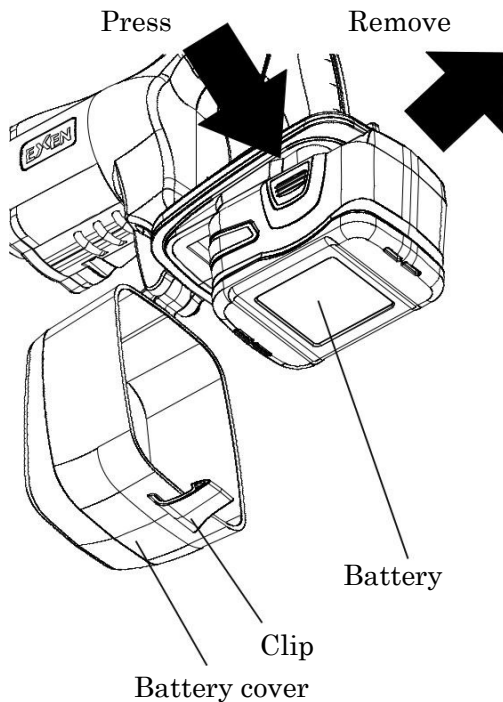

■ Removal

1. Remove the clip of the battery cover, and then open the battery cover.
2. Press both yellow buttons on both sides of the battery pack and remove it.

■ Attachment

1. Put a battery pack on the charger align rails on motor assembly and battery holder. Slide the battery back forward onto the charger until it stops.
2. Close the battery cover before use.
If the battery cover contacts the battery and does not close, put the battery back into the place again and try to close the battery cover.

○ CLEANING AND TRANSPORTATION AFTER USE

- After use, should be cleaned well.
 1. Remove the battery from the motor assembly for cleaning and transportation.
 2. The concrete attached to the vibrator should be removed before it hardens.
 3. Remove the dust and concrete on the motor assembly.
 4. For transportation, hold the motor assembly or the vibrator assembly and carry the vibrator.
 5. Do not wash the motor assembly with water.
(Wipe the motor assembly with a dry damp cloth or a cloth moistened with detergent.)



○ INSPECTION

- Before carrying the vibrator to the fields and also after use, be sure to check the followings.

It prevents any trouble as much as possible during use.

1. Are there any wear, cracks or damage on the head assembly?
2. Looseness of the fix bolt on the vibration portion? (C25DS, 28D, 28DL)
3. Are there any wear, damage or scratches on the flexible hose? (C28F)
4. Is there any dirt or rust on the terminals?
5. Can the switch be turn ON and OFF properly?
6. Is the vibrator operation sound normal during operation?
(It is normal if there is regular and continuous sound.)
7. Switch lock function (Lock/Release)

○ REPLACEMENT PERIOD FOR CONSUMABLES

- Consumables should be replaced periodically according to the below table.

Consumables	Replacement period by sight and hearing	Replacement period (Target: hours)
Head housing	Determine depending on the wear (visual)	300 - 500
Lubricating oil	Determine from noise during operation (audible)	100 - 200
Bearing	Determine from noise during operation (audible)	100 - 300
Motor	Rotation stops due to brush wear (audible/visual)	200
Flexible hose	Determine depending on the wear or scratches (visual)	Upon found
Flexible shaft	Determine depending on the wear (visual)	Upon found
Battery	Determine depending on charger display (visual)	Upon found



○ TROUBLESHOOTING

Operation	Phenomenon	Cause	Action
Enabled	Noise (metallic or other noise)	Bad bearings (Rough, Worn)	Replace the bearings.
		Deterioration of the grease	Replace the grease.
		Wear of head assembly (bearing mounting part)	Replace head assembly.
	Low vibration	Motor abnormality	Replace the motor.
		Battery abnormality	Replace the battery.
	No vibration	Fracture of flexible shaft	Replace flexible shaft.
Damage to spring assembly		Replacement of spring assembly.	
Disabled	Humming noise	Bad bearings (Locking/Broken)	Replace the bearings.
		Motor abnormality	Replace the motor.
	No sound	Battery failure	Charging/Replacing Batteries.
		Broken lead wire	Repair or replace motor.
Not chargeable	Lamp OFF	Charger error	Replace charger.
	Lamp ON	Abnormal battery temperature	Wait until the temperature drops while hot. (Wait until temperature rises while cold.)
		Battery abnormality	Replace the battery.
Short operating time even after charging		End of a product's life	Replace the battery.

○ SPECIFICATIONS

■ VIBRATION TOTAL VALUE

Model	Vibration total value (m/s ²)
E-VIB (0.7m)	3.8

※ Vibration total value is a value which used the measuring instrument based on JIS B7761-1, and was measured by the method based on JIS B7761-2.

■SPECIFICATIONS

Model	Output [W]	Voltage [V]	Current [A]	Frequency [Hz]	Total length [mm]	Head length Diameter × Length [mm]	Operating time* ₁ [Minute]	Mass * ₂ [kg]
C25DS	125	18	8	200	767	φ 25×447	30	4.1
C28D					795	φ <small>28×175</small>	25	4.2
C28DL					955	φ 28×635	25	5.0
C28F (0.6m)			1089		φ 28×186	20	4.2	

*1: Time that we checked operation with our standard.

*2: Mass including a battery (0.8 kg)

■C25DS, 28D, 28DL

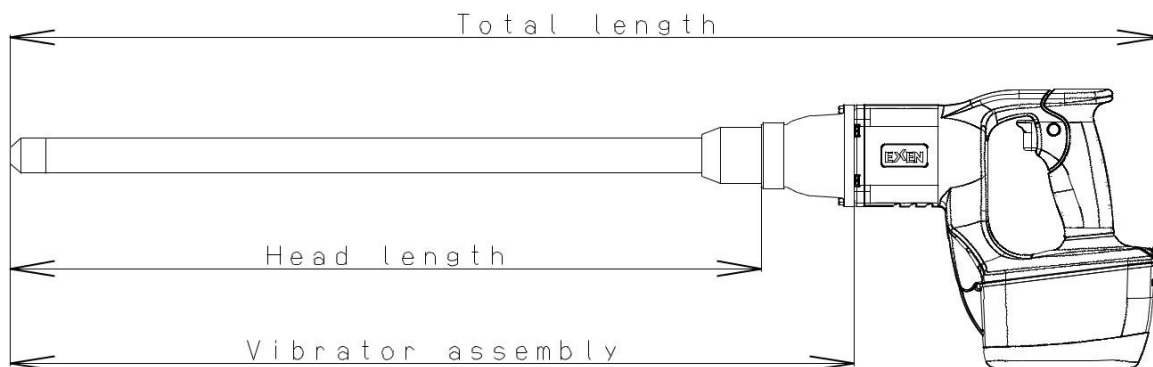

■C28F

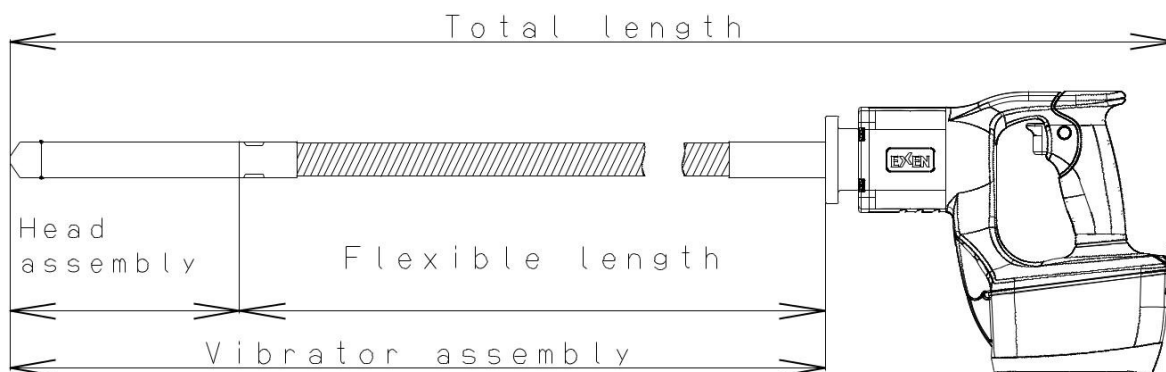





Uni-corp Europe S.A.R.L.
Paclite Equipment

ZAC des petits Carreaux
12 avenue des Coquelicots
94380 Bonneuil sur Marne,
FRANCE

 +33 (0) 1 49 56 02 82

 +33 (0) 1 43 99 19 50

 sales@paclite-equip.com

 paclite-equip.com



2010